

Comparative Analysis of Esophageal Sampling Devices: A Guide for Researchers

Author: BenchChem Technical Support Team. **Date:** April 2026

Compound of Interest

Compound Name: Z1078601926

Cat. No.: B7568919

[Get Quote](#)

This guide provides a comparative overview of various esophageal sampling methods, offering researchers, scientists, and drug development professionals a comprehensive look at the performance and methodologies of alternatives to the Esophageal Sampling Device BESD-001 (also known as **Z1078601926**). The data presented is based on published findings for comparable non-endoscopic and traditional endoscopic techniques.

Quantitative Performance of Esophageal Sampling Methods

The following tables summarize key performance metrics from studies comparing different esophageal sampling devices. These metrics are crucial for selecting the appropriate tool for clinical research and diagnostics.

Table 1: Diagnostic Performance of Non-Endoscopic Devices for Esophageal Conditions

Device/Method	Condition	Sensitivity	Specificity	Subject Count (n)	Citation
Cytosponge™	Any Barrett's Esophagus (BE)	74%	85%	142	[1]
Cytosponge™	Residual/Resurgent BE	69%	84%	175	[1]
Cytosponge™	Eosinophilic Esophagitis (EoE)	75%	86%	86	[2]
Cytosponge™	Eosinophilic Esophagitis (EoE)	70%	56%	20	[2]
Liquid-Based Cytology (LBC)	Eosinophilic Esophagitis (EoE)	70%	81%	N/A	[2]
EsoCheck™ with EG Assay	BE & Esophageal Adenocarcinoma (EAC)	85%	84%	242	[3][4]
EsoCheck™ with EG Assay	Short-Segment BE (< 3 cm)	76%	N/A	37	[3][4]
EsoCheck™ with EG Assay	Cancers (EAC/JAC)	100%	N/A	18	[3][4]

Table 2: Comparison of Cellular and Microbial Yield

Sampling Method	Comparison Metric	Result	p-value	Citation
Cytosponge™ vs. Endoscopic Brushes	Microbial DNA Yield	>10-fold higher with Cytosponge™	<0.001	[5]
Cytosponge™ vs. Biopsies	Microbial DNA Yield	>10-fold higher with Cytosponge™	<0.0001	[5]
Balloon vs. Sponge vs. Sponge-mesh Samplers	Adequate Squamous & Glandular Cells	>78% for all methods	No significant difference	[6]

Table 3: Patient Preference and Usability

Sampler Type	Preference	Note	Citation
Encapsulated Samplers (Sponge, Sponge-mesh)	Significantly preferred over balloon	-	[6]
Balloon Sampler	Less preferred	-	[6]

Experimental Protocols

Detailed methodologies are essential for replicating and building upon published research. Below are summaries of protocols used in key studies of esophageal sampling.

Protocol for Cytosponge™ Microbiome Analysis

A study comparing the esophageal microbiota in patients with and without esophageal adenocarcinoma (OAC) utilized the Cytosponge™ alongside endoscopic brushing and biopsies.[5]

- **Sample Collection:** Three types of esophageal samples were collected: fresh frozen tissue, fresh frozen endoscopic brushings, and samples from the Cytosponge™ device.[5]
- **DNA Extraction and Sequencing:** 16S rRNA gene amplicon sequencing was performed on all 210 esophageal samples on the Illumina MiSeq platform to analyze the microbial community. [5]
- **Quantitative Analysis:** Microbial DNA yield was quantified using qPCR.[5]
- **Data Analysis:** Microbial diversity was assessed using observed OTU richness, Chao estimated total richness, and the Shannon diversity index.[5]

Protocol for Comparative Study of Esophageal Exfoliative Cytology Samplers

A controlled, single-blind, cross-over study was conducted to compare balloon, sponge, and sponge-mesh esophageal cytology samplers.[6]

- **Study Design:** 62 healthy volunteers each underwent procedures with the three samplers in a random order.[6]
- **Patient Acceptability:** After the procedures, participants were asked to state their preferred method.[6]
- **Ease of Use:** This was determined by the technician's ability to successfully perform the intubation.[6]
- **Sampler Destination:** The final position of the sampler tip in the gastrointestinal tract was assessed fluoroscopically.[6]
- **Cellular Yield:** Cytopathologists evaluated the cellular yield of each sampler based on the Bethesda System.[6]

Protocol for EsoCheck™ Device with EsoGuard™ Assay

A multi-center study validated a non-endoscopic screening test for BE and EAC using the EsoCheck™ encapsulated balloon device and the EsoGuard™ biomarker panel.[3][4]

- Patient Cohort: The study included 88 cases (with BE or EAC) and 154 controls.[3][4]
- Sample Collection: Trained personnel administered the encapsulated balloon orally. The balloon was inflated in the stomach, withdrawn to sample the distal 5 cm of the esophagus, and then retracted back into the capsule to prevent contamination.[4] The average time for sample collection was just over 3 minutes.[3][4]
- Sample Preservation: A room temperature preservative was used to enable office-based testing.[3]
- Biomarker Analysis: DNA was extracted from the samples, treated with bisulfite, and analyzed using Next-Generation Sequencing for methylated Vimentin (mVIM) and Cyclin A1 (mCCNA1) in a CLIA-certified lab.[4]

Visualizing Experimental Workflows and Relationships

The following diagrams, generated using Graphviz, illustrate key experimental workflows and logical relationships described in the cited studies.

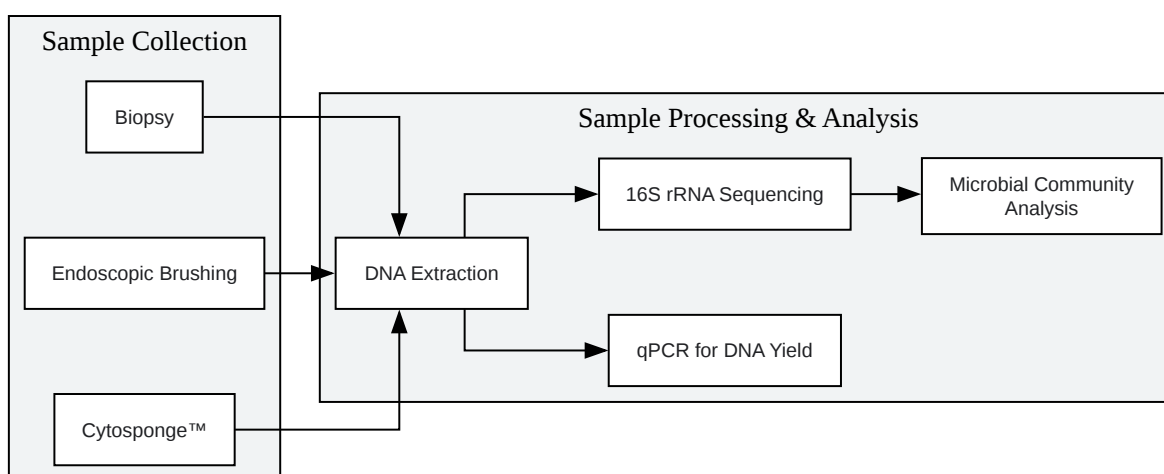

[Click to download full resolution via product page](#)

Caption: Workflow for esophageal microbiome analysis.

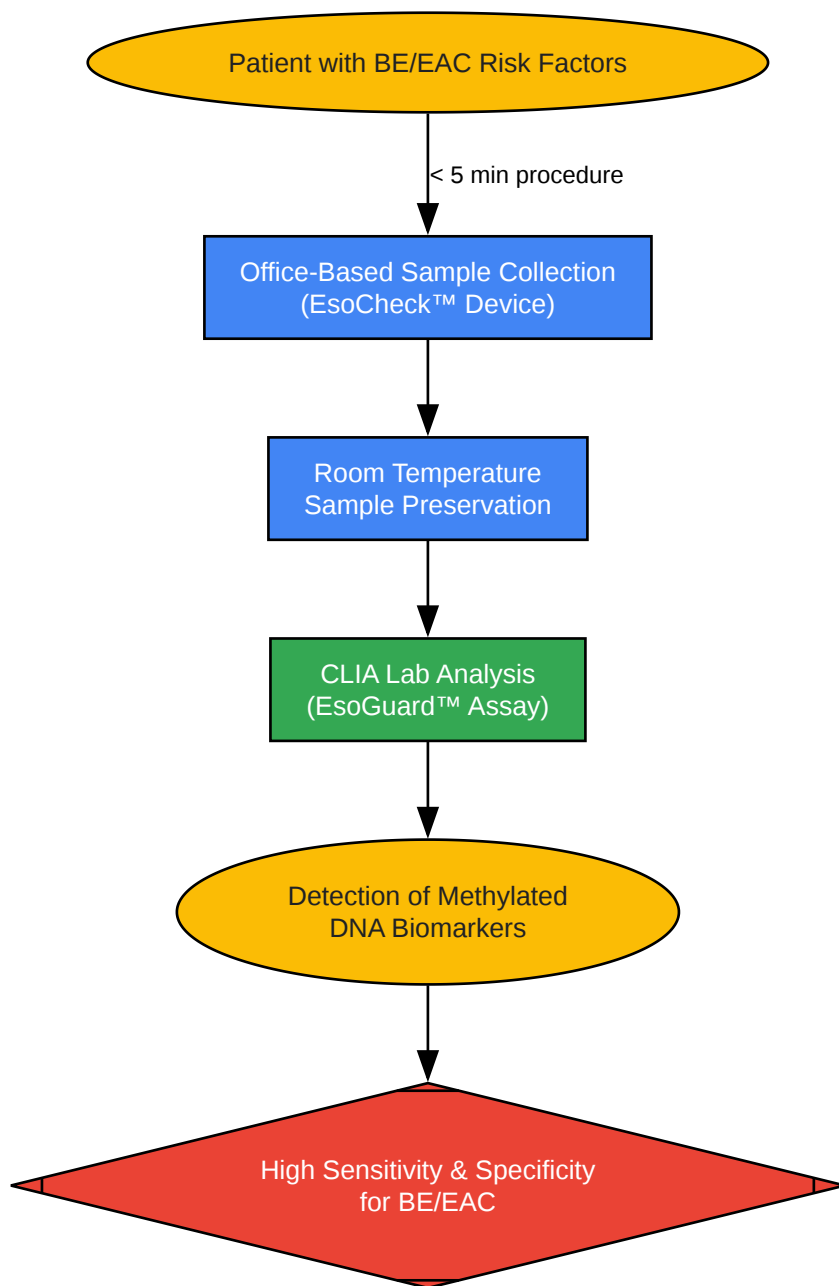

[Click to download full resolution via product page](#)

Caption: Non-endoscopic screening workflow for BE and EAC.

Need Custom Synthesis?

BenchChem offers custom synthesis for rare earth carbides and specific isotopic labeling.

Email: info@benchchem.com or [Request Quote Online](#).

References

- 1. UTILITY AND COST-EFFECTIVENESS OF A NON-ENDOSCOPIC APPROACH TO BARRETT'S ESOPHAGUS SURVEILLANCE AFTER ENDOSCOPIC THERAPY - PMC [[pmc.ncbi.nlm.nih.gov](https://pubmed.ncbi.nlm.nih.gov)]
- 2. Non-endoscopic Biomarkers and Sampling for Diagnosis and Monitoring of Adult Eosinophilic Esophagitis: A Systematic Review and Pooled Analysis - PMC [[pmc.ncbi.nlm.nih.gov](https://pubmed.ncbi.nlm.nih.gov)]
- 3. NON-ENDOSCOPIC ESOPHAGEAL SAMPLING DEVICE AND BIOMARKER PANEL FOR DETECTION OF BARRETT'S ESOPHAGUS (BE) AND ESOPHAGEAL ADENOCARCINOMA (EAC) - PubMed [pubmed.ncbi.nlm.nih.gov]
- 4. [researchgate.net](https://www.researchgate.net) [[researchgate.net](https://www.researchgate.net)]
- 5. [abdn.elsevierpure.com](https://www.abdn.elsevierpure.com) [[abdn.elsevierpure.com](https://www.abdn.elsevierpure.com)]
- 6. Esophageal exfoliative cytology samplers. A comparison of three types - PubMed [pubmed.ncbi.nlm.nih.gov]
- To cite this document: BenchChem. [Comparative Analysis of Esophageal Sampling Devices: A Guide for Researchers]. BenchChem, [2026]. [Online PDF]. Available at: [<https://www.benchchem.com/product/b7568919/docs#comparative-analysis-of-esophageal-sampling-devices-a-guide-for-researchers>]

Disclaimer & Data Validity:

The information provided in this document is for Research Use Only (RUO) and is strictly not intended for diagnostic or therapeutic procedures. While BenchChem strives to provide accurate protocols, we make no warranties, express or implied, regarding the fitness of this product for every specific experimental setup.

Technical Support: The protocols provided are for reference purposes. Unsure if this reagent suits your experiment?

Need Industrial/Bulk Grade? [Request Custom Synthesis Quote](#)

BenchChem

Our mission is to be the trusted global source of essential and advanced chemicals, empowering scientists and researchers to drive progress in science and industry.

Contact

Address: 3281 E Guasti Rd

Ontario, CA 91761, United States

Phone: (601) 213-4426

Email: info@benchchem.com

[Contact our Ph.D. Support Team for a compatibility check](#)