

# Technical Support Center: Enhancing the Cellular Uptake of NRX-1532

**Author:** BenchChem Technical Support Team. **Date:** April 2026

## Compound of Interest

Compound Name: NRX-1532

Cat. No.: B7539272

[Get Quote](#)

Disclaimer: As "NRX-1532" is not a publicly documented compound, this guide is based on the hypothetical scenario that NRX-1532 is a novel hydrophobic small molecule drug candidate. The following troubleshooting advice, protocols, and data are derived from established methods for enhancing the cellular uptake of such compounds.

## Troubleshooting Guide

This section addresses common issues encountered during cellular uptake experiments with hydrophobic compounds like NRX-1532.

Question/Issue	Possible Cause	Suggested Solution
<p>Why am I observing very low or no intracellular concentration of NRX-1532?</p>	<p>Poor aqueous solubility: NRX-1532 may be precipitating in your aqueous cell culture medium.</p>	<p>1. Use a solubilizing agent: Formulate NRX-1532 with cyclodextrins to increase its solubility.<a href="#">[1]</a><a href="#">[2]</a><a href="#">[3]</a><a href="#">[4]</a><a href="#">[5]</a> 2. Liposomal formulation: Encapsulate NRX-1532 in liposomes to facilitate its transport across the cell membrane.<a href="#">[6]</a><a href="#">[7]</a><a href="#">[8]</a><a href="#">[9]</a> 3. Co-solvent system: Dissolve NRX-1532 in a small amount of a biocompatible solvent (e.g., DMSO) before diluting it in the final medium. Ensure the final solvent concentration is non-toxic to your cells.</p>
<p>I see evidence of NRX-1532 binding to the outside of the cells, but not being internalized. What can I do?</p>	<p>Inefficient membrane translocation: The compound may be associating with the cell membrane but not efficiently crossing it.</p>	<p>1. Cell-penetrating peptides (CPPs): Conjugate NRX-1532 to a CPP to actively drive it across the cell membrane.<a href="#">[10]</a><a href="#">[11]</a><a href="#">[12]</a><a href="#">[13]</a><a href="#">[14]</a> 2. Permeation enhancers: Co-administer NRX-1532 with a mild permeation enhancer, but be cautious of cytotoxicity.</p>
<p>My uptake results are highly variable between experiments. How can I improve consistency?</p>	<p>Inconsistent formulation: The NRX-1532 formulation (e.g., liposomes, cyclodextrin complexes) may not be uniform. Cell health variability: Differences in cell confluence, passage number, or overall health can affect uptake.</p>	<p>1. Characterize your formulation: Ensure consistent particle size and encapsulation efficiency for liposomes, or a stable complex formation with cyclodextrins. 2. Standardize cell culture conditions: Use cells within a specific passage number range, seed at a consistent density, and ensure</p>

high viability before starting the experiment.

I'm observing significant cytotoxicity at concentrations where I expect to see uptake. What's the issue?

Compound toxicity: NRX-1532 itself may be toxic at the required concentrations.

Formulation toxicity: The delivery vehicle (e.g., certain CPPs, high concentrations of cyclodextrins) may be causing cell death.

1. Dose-response curve: Perform a cytotoxicity assay (e.g., MTT, LDH) to determine the maximum non-toxic concentration of NRX-1532 and your formulation components. 2. Optimize formulation: Test different types of cyclodextrins or lipid compositions for liposomes to find a less toxic alternative.<sup>[1]</sup>

## Frequently Asked Questions (FAQs)

Q1: What is the best solvent to dissolve **NRX-1532** for in vitro experiments?

A1: For hydrophobic compounds like **NRX-1532**, it is recommended to first dissolve the compound in a minimal amount of a water-miscible organic solvent such as dimethyl sulfoxide (DMSO). The stock solution can then be diluted in your aqueous experimental buffer or cell culture medium. It is crucial to keep the final concentration of the organic solvent low (typically <0.5%) to avoid solvent-induced cytotoxicity.

Q2: How can I quantify the intracellular concentration of **NRX-1532**?

A2: Quantifying intracellular drug concentrations is crucial for understanding its efficacy and toxicity.<sup>[15][16][17][18]</sup> A common method involves treating cells with **NRX-1532** for a specific duration, followed by thorough washing to remove any extracellular compound. The cells are then lysed, and the concentration of **NRX-1532** in the lysate is determined using a sensitive analytical technique such as liquid chromatography-mass spectrometry (LC-MS).<sup>[17]</sup>

Q3: Can I use fluorescence microscopy to track the uptake of **NRX-1532**?

A3: If **NRX-1532** is intrinsically fluorescent or has been labeled with a fluorophore, fluorescence microscopy is an excellent qualitative and semi-quantitative method to visualize its cellular

uptake and subcellular localization. Confocal microscopy is particularly useful for distinguishing between membrane-bound and internalized compounds. Flow cytometry can also be used for a more quantitative analysis of cellular fluorescence.[19]

Q4: What are the key differences between using cyclodextrins and liposomes to enhance uptake?

A4: Cyclodextrins are cyclic oligosaccharides that form inclusion complexes with hydrophobic molecules, effectively increasing their solubility in aqueous solutions.[1][3][4][5] This can lead to a higher concentration of the drug at the cell surface, promoting passive diffusion. Liposomes, on the other hand, are lipid vesicles that can encapsulate drugs and deliver them into cells through mechanisms like membrane fusion or endocytosis.[6][7][8][9] The choice between the two depends on the specific properties of **NRX-1532** and the desired delivery mechanism.

## Data Presentation

The following tables provide a hypothetical comparison of different methods to enhance the cellular uptake of **NRX-1532**.

Table 1: Comparison of **NRX-1532** Intracellular Concentration with Different Delivery Methods

Delivery Method	NRX-1532 Concentration ( $\mu\text{M}$ )	Intracellular Concentration ( $\text{ng}/10^6$ cells)	Fold Increase vs. Control
Control (NRX-1532 alone)	10	$15.2 \pm 2.1$	1.0
HP- $\beta$ -Cyclodextrin	10	$78.5 \pm 5.6$	5.2
DOPC/Cholesterol Liposomes	10	$155.3 \pm 11.8$	10.2
TAT-Conjugate	10	$258.1 \pm 19.4$	17.0

Table 2: Cytotoxicity of Different **NRX-1532** Formulations

Formulation	Concentration ( $\mu\text{M}$ )	Cell Viability (%)
Vehicle Control	-	98.7 $\pm$ 1.5
NRX-1532 alone	10	95.3 $\pm$ 2.8
HP- $\beta$ -Cyclodextrin	10	92.1 $\pm$ 3.1
DOPC/Cholesterol Liposomes	10	94.5 $\pm$ 2.5
TAT-Conjugate	10	88.6 $\pm$ 4.2

## Experimental Protocols

### Protocol 1: Formulation of NRX-1532 with Hydroxypropyl- $\beta$ -Cyclodextrin (HP- $\beta$ -CD)

- Preparation of **NRX-1532** Stock Solution: Dissolve **NRX-1532** in a suitable organic solvent (e.g., DMSO) to prepare a concentrated stock solution (e.g., 10 mM).
- Preparation of HP- $\beta$ -CD Solution: Prepare a stock solution of HP- $\beta$ -CD in your desired aqueous buffer (e.g., PBS or cell culture medium) at a concentration of 100 mM.
- Complex Formation:
  - Add the **NRX-1532** stock solution to the HP- $\beta$ -CD solution at a molar ratio of 1:10 (**NRX-1532**:HP- $\beta$ -CD).
  - Incubate the mixture at 37°C for 1 hour with constant agitation to facilitate the formation of the inclusion complex.
- Sterilization and Use: Sterilize the final formulation by passing it through a 0.22  $\mu\text{m}$  filter. The complex is now ready for use in cell culture experiments.

### Protocol 2: Preparation of NRX-1532-Loaded Liposomes by Thin-Film Hydration

- Lipid Mixture Preparation:

- In a round-bottom flask, dissolve DOPC (1,2-dioleoyl-sn-glycero-3-phosphocholine) and cholesterol in a 2:1 molar ratio in chloroform.
- Add **NRX-1532** to the lipid mixture at a drug-to-lipid ratio of 1:20 (w/w).
- Thin-Film Formation:
  - Evaporate the chloroform using a rotary evaporator under vacuum to form a thin, uniform lipid film on the inner surface of the flask.
  - Further dry the film under a stream of nitrogen gas for at least 1 hour to remove any residual solvent.
- Hydration:
  - Hydrate the lipid film with a suitable aqueous buffer (e.g., PBS) by vortexing for 30 minutes at a temperature above the lipid phase transition temperature. This will result in the formation of multilamellar vesicles (MLVs).
- Size Extrusion:
  - To obtain unilamellar vesicles of a defined size, subject the MLV suspension to extrusion through polycarbonate membranes with a specific pore size (e.g., 100 nm) using a mini-extruder. Pass the suspension through the membrane 11-21 times.
- Purification: Remove any unencapsulated **NRX-1532** by size exclusion chromatography or dialysis.

## Mandatory Visualization

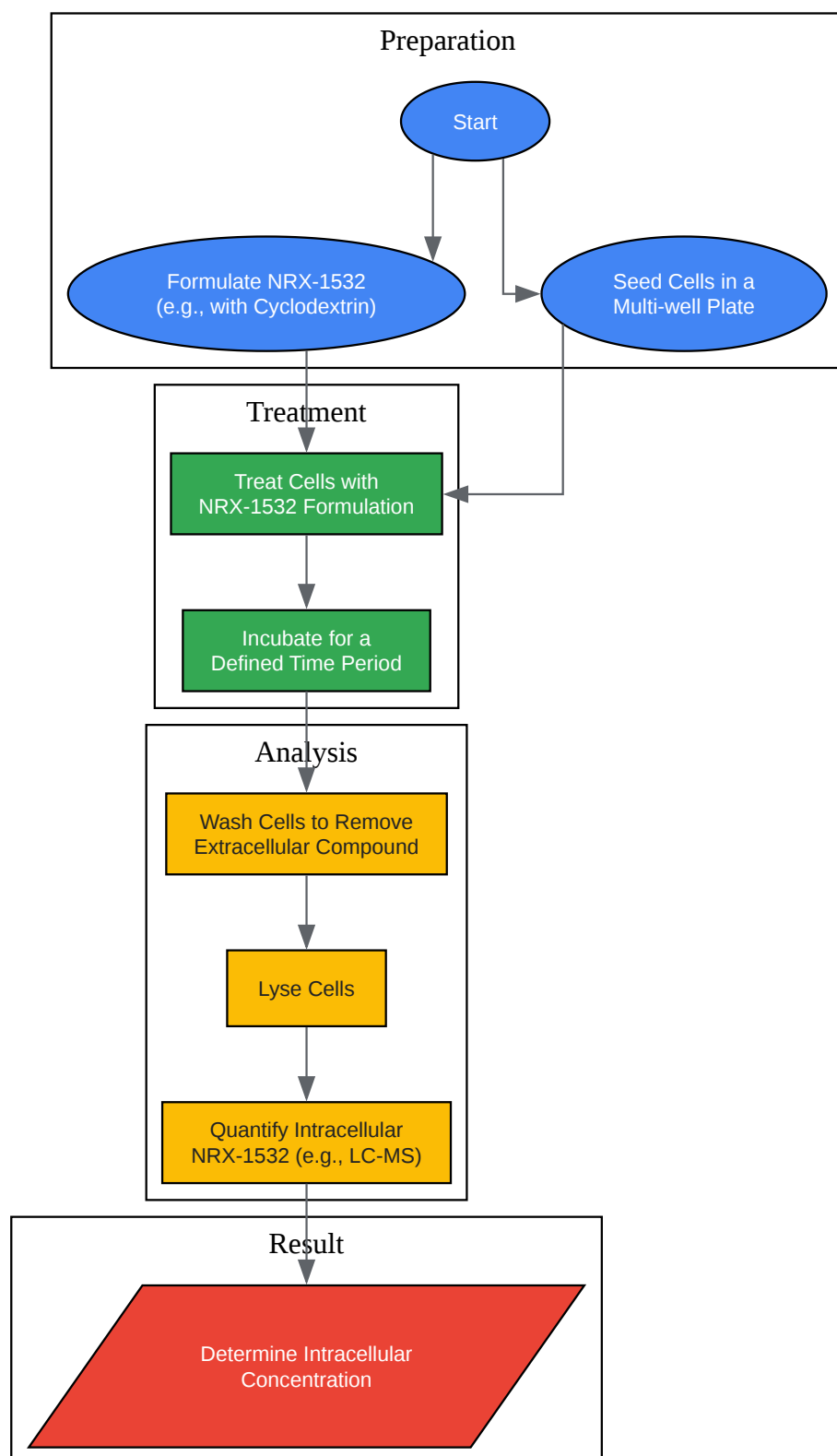

[Click to download full resolution via product page](#)

Caption: Workflow for a cellular uptake experiment of **NRX-1532**.

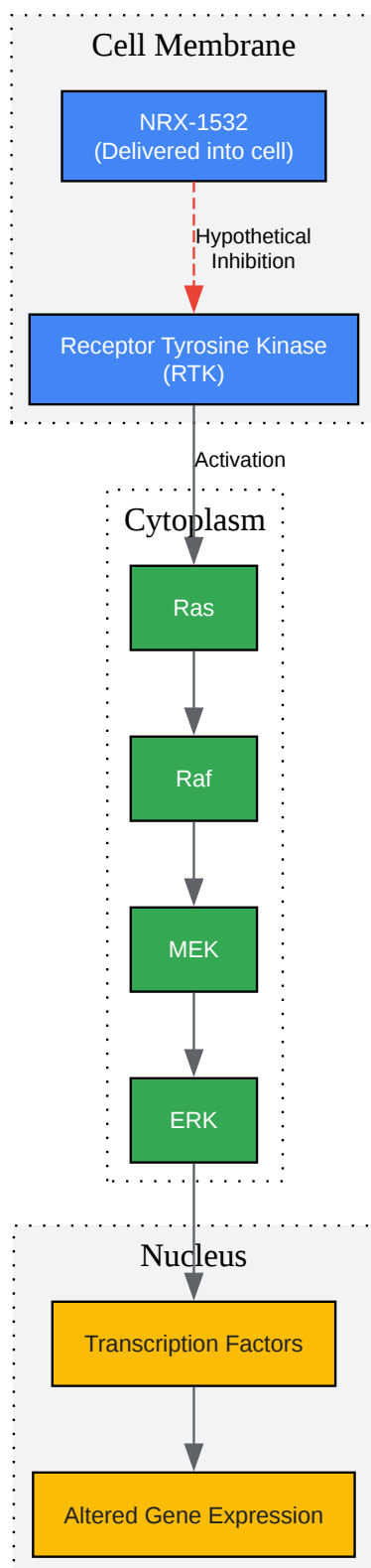

[Click to download full resolution via product page](#)

Caption: Hypothetical signaling pathway inhibited by intracellular **NRX-1532**.<sup>[20][21][22][23][24]</sup>

### Need Custom Synthesis?

BenchChem offers custom synthesis for rare earth carbides and specific isotopic labeling.

Email: [info@benchchem.com](mailto:info@benchchem.com) or [Request Quote Online](#).

## References

- [1. chemicaljournals.com](https://www.chemicaljournals.com) [chemicaljournals.com]
- [2. Cyclodextrin Complexation Improves the Solubility and Caco-2 Permeability of Chrysin - PMC](https://pubmed.ncbi.nlm.nih.gov/31111111/) [pmc.ncbi.nlm.nih.gov]
- [3. scispace.com](https://www.scispace.com) [scispace.com]
- [4. Cyclodextrins: Enhancing Drug Delivery, Solubility and Bioavailability for Modern Therapeutics - PMC](https://pubmed.ncbi.nlm.nih.gov/31111111/) [pmc.ncbi.nlm.nih.gov]
- [5. Solubility of Cyclodextrins and Drug/Cyclodextrin Complexes - PMC](https://pubmed.ncbi.nlm.nih.gov/31111111/) [pmc.ncbi.nlm.nih.gov]
- [6. youtube.com](https://www.youtube.com) [youtube.com]
- [7. mdpi.com](https://www.mdpi.com) [mdpi.com]
- [8. Methods of Liposomes Preparation: Formation and Control Factors of Versatile Nanocarriers for Biomedical and Nanomedicine Application - PMC](https://pubmed.ncbi.nlm.nih.gov/31111111/) [pmc.ncbi.nlm.nih.gov]
- [9. liposomes.ca](https://www.liposomes.ca) [liposomes.ca]
- [10. Delivery of Proteins, Peptides or Cell-impermeable Small Molecules into Live Cells by Incubation with the Endosomolytic Reagent dfTAT - PubMed](https://pubmed.ncbi.nlm.nih.gov/31111111/) [pubmed.ncbi.nlm.nih.gov]
- [11. creative-diagnostics.com](https://www.creative-diagnostics.com) [creative-diagnostics.com]
- [12. drugdiscoverytrends.com](https://www.drugdiscoverytrends.com) [drugdiscoverytrends.com]
- [13. mdpi.com](https://www.mdpi.com) [mdpi.com]
- [14. Redesigning of Cell-Penetrating Peptides to Improve Their Efficacy as a Drug Delivery System - PMC](https://pubmed.ncbi.nlm.nih.gov/31111111/) [pmc.ncbi.nlm.nih.gov]
- [15. Quantitative Analysis of Intracellular Drug Concentrations in Hepatocytes | Springer Nature Experiments](https://www.nature.com/experiments) [experiments.springernature.com]
- [16. Intracellular Drug Concentrations and Transporters: Measurement, Modeling, and Implications for the Liver - PMC](https://pubmed.ncbi.nlm.nih.gov/31111111/) [pmc.ncbi.nlm.nih.gov]
- [17. researchgate.net](https://www.researchgate.net) [researchgate.net]

- [18. research.manchester.ac.uk](https://research.manchester.ac.uk) [[research.manchester.ac.uk](https://research.manchester.ac.uk)]
- [19. Cellular Drug Uptake by Flow Cytometry | Nawah Scientific](https://www.nawah-scientific.com) [[nawah-scientific.com](https://www.nawah-scientific.com)]
- [20. researchgate.net](https://www.researchgate.net) [[researchgate.net](https://www.researchgate.net)]
- [21. researchgate.net](https://www.researchgate.net) [[researchgate.net](https://www.researchgate.net)]
- [22. Kinase Signaling Pathways | Cell Signaling Technology](https://www.cellsignal.com) [[cellsignal.com](https://www.cellsignal.com)]
- [23. bio.libretexts.org](https://bio.libretexts.org) [[bio.libretexts.org](https://bio.libretexts.org)]
- [24. Receptor tyrosine kinases: mechanisms of activation and signaling - PMC](https://pubmed.ncbi.nlm.nih.gov) [[pmc.ncbi.nlm.nih.gov](https://pubmed.ncbi.nlm.nih.gov)]
- To cite this document: BenchChem. [Technical Support Center: Enhancing the Cellular Uptake of NRX-1532]. BenchChem, [2026]. [Online PDF]. Available at: [<https://www.benchchem.com/product/b7539272/docs#technical-support-center-enhancing-the-cellular-uptake-of-nrx-1532>]

---

#### Disclaimer & Data Validity:

The information provided in this document is for Research Use Only (RUO) and is strictly not intended for diagnostic or therapeutic procedures. While BenchChem strives to provide accurate protocols, we make no warranties, express or implied, regarding the fitness of this product for every specific experimental setup.

**Technical Support:** The protocols provided are for reference purposes. Unsure if this reagent suits your experiment?

**Need Industrial/Bulk Grade?** [Request Custom Synthesis Quote](#)

## BenchChem

Our mission is to be the trusted global source of essential and advanced chemicals, empowering scientists and researchers to drive progress in science and industry.

#### Contact

Address: 3281 E Guasti Rd

Ontario, CA 91761, United States

Phone: (601) 213-4426

Email: [info@benchchem.com](mailto:info@benchchem.com)

Contact our Ph.D. Support Team for a compatibility check