

# Application Notes and Protocols for NRX-1532 In Vitro Cell-Based Assays

**Author:** BenchChem Technical Support Team. **Date:** April 2026

## Compound of Interest

Compound Name: NRX-1532

Cat. No.: B7539272

[Get Quote](#)

For Researchers, Scientists, and Drug Development Professionals

## Introduction

**NRX-1532** is a small molecule that functions as a molecular glue, enhancing the interaction between  $\beta$ -catenin and the E3 ubiquitin ligase  $\beta$ -TrCP.[1][2] This enhanced interaction facilitates the ubiquitination and subsequent proteasomal degradation of  $\beta$ -catenin, particularly mutant forms of  $\beta$ -catenin that are implicated in various cancers.[2] These application notes provide detailed protocols for a suite of in vitro cell-based assays to characterize the biochemical and cellular activity of **NRX-1532**.

## Mechanism of Action: Wnt/ $\beta$ -catenin Signaling Pathway

The Wnt/ $\beta$ -catenin signaling pathway is crucial in cell fate determination, proliferation, and differentiation. In the absence of a Wnt signal, a destruction complex composed of APC, Axin, and GSK3 $\beta$  phosphorylates  $\beta$ -catenin, targeting it for ubiquitination by the SCF( $\beta$ -TrCP) E3 ligase complex and subsequent proteasomal degradation. Mutations in  $\beta$ -catenin, particularly at serine/threonine residues (e.g., S33, S37), can impair its recognition by the destruction

complex, leading to its accumulation, nuclear translocation, and constitutive activation of target genes such as c-myc and cyclin D1, driving oncogenesis.[3][4][5][6][7] **NRX-1532** acts by stabilizing the interaction between mutant  $\beta$ -catenin and  $\beta$ -TrCP, thereby restoring its degradation.

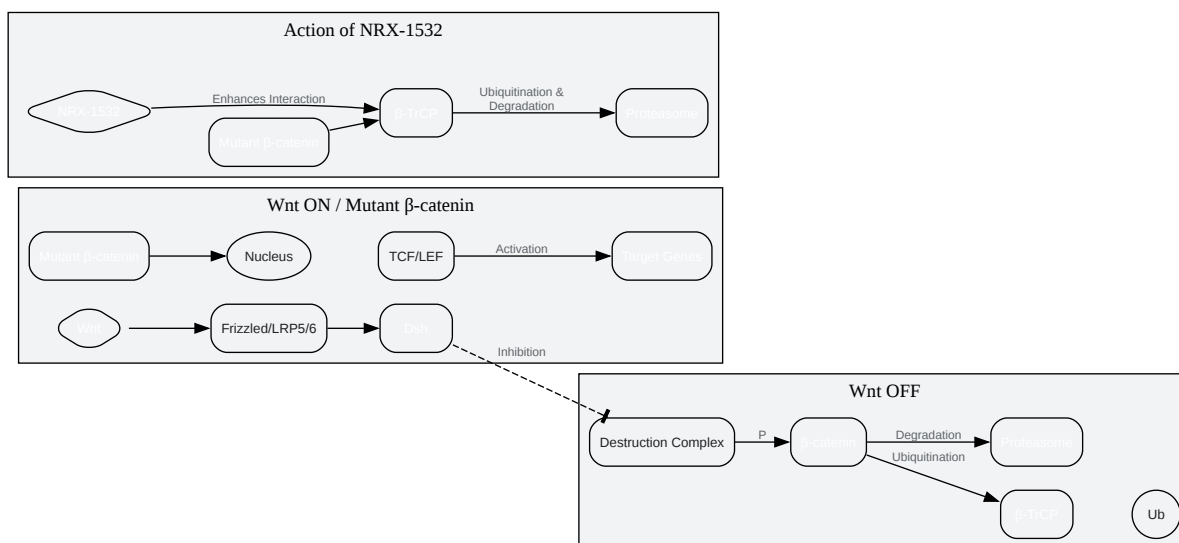

[Click to download full resolution via product page](#)

**Figure 1:** Wnt/ $\beta$ -catenin signaling and the mechanism of **NRX-1532**.

## Data Presentation

The following tables summarize the quantitative data for **NRX-1532** in various in vitro assays.

Table 1: Biochemical Binding Assays of **NRX-1532**

Assay Type	EC50 ( $\mu\text{M}$ )	Reference
Fluorescence Polarization (FP)	206 $\pm$ 54	[1][8]
Time-Resolved Fluorescence Resonance Energy Transfer (TR-FRET)	246 $\pm$ 17	[1][8]
Surface Plasmon Resonance (SPR)	129 $\pm$ 33	[1][8]

Table 2: **NRX-1532**-Mediated Enhancement of  $\beta$ -catenin: $\beta$ -TrCP Binding Affinity (TR-FRET)

NRX-1532 Concentration	Binding Affinity (Kd, nM)	Fold Cooperativity	Reference
0 $\mu\text{M}$	689	1	[1]
500 $\mu\text{M}$	68	10	[1]

## Experimental Protocols

### Biochemical Assays to Measure **NRX-1532**-Enhanced Protein-Protein Interaction

These assays quantify the direct binding of  $\beta$ -catenin and  $\beta$ -TrCP and the enhancing effect of **NRX-1532**.

Principle: This assay measures the change in the polarization of fluorescently labeled  $\beta$ -catenin peptide upon binding to the larger  $\beta$ -TrCP protein. Enhancement of this interaction by **NRX-1532** leads to a dose-dependent increase in fluorescence polarization.

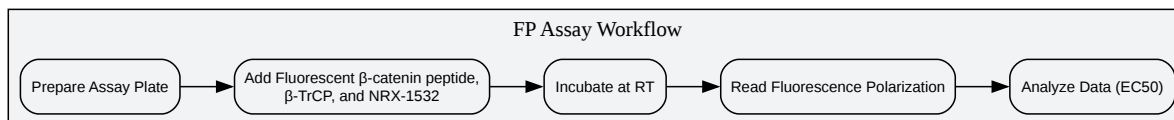

[Click to download full resolution via product page](#)

**Figure 2:** Fluorescence Polarization (FP) Assay Workflow.

Protocol:

- Reagents:

- Fluorescently labeled  $\beta$ -catenin peptide (e.g., BODIPY-TMR-labeled phosphoserine 33/37  $\beta$ -catenin peptide).
- Purified  $\beta$ -TrCP protein complex.
- **NRX-1532** stock solution (in DMSO).
- Assay Buffer (e.g., 20 mM Tris pH 7.5, 150 mM NaCl, 0.01% Tween-20).

- Procedure:

1. Prepare a serial dilution of **NRX-1532** in assay buffer.
2. In a 384-well black plate, add a constant concentration of fluorescently labeled  $\beta$ -catenin peptide (e.g., 5 nM).
3. Add a constant concentration of  $\beta$ -TrCP, titrated to result in approximately 20% binding saturation in the absence of the compound.
4. Add the serially diluted **NRX-1532** or DMSO (vehicle control) to the wells.
5. Incubate the plate at room temperature for 1-2 hours, protected from light.

6. Measure fluorescence polarization using a plate reader equipped with appropriate filters for the fluorophore.
7. Calculate the EC50 value by fitting the dose-response curve.

Principle: This assay measures the energy transfer between a donor fluorophore (e.g., Europium-chelate) conjugated to an anti-tag antibody recognizing tagged  $\beta$ -TrCP and an acceptor fluorophore (e.g., APC) conjugated to a binding partner of  $\beta$ -catenin. Interaction brings the donor and acceptor into proximity, resulting in a FRET signal. **NRX-1532** enhances this signal in a dose-dependent manner.

Protocol:

- Reagents:
  - Tagged (e.g., His-tagged)  $\beta$ -TrCP.
  - Biotinylated  $\beta$ -catenin peptide.
  - Europium-chelate labeled anti-tag antibody (e.g., Anti-His-Eu).
  - Streptavidin-conjugated acceptor fluorophore (e.g., SA-APC).
  - **NRX-1532** stock solution (in DMSO).
  - TR-FRET Assay Buffer.
- Procedure:
  1. Prepare serial dilutions of **NRX-1532**.
  2. In a 384-well white plate, add tagged  $\beta$ -TrCP and biotinylated  $\beta$ -catenin peptide.
  3. Add the serially diluted **NRX-1532** or DMSO.
  4. Add the Europium-labeled antibody and Streptavidin-acceptor.
  5. Incubate at room temperature for 2-4 hours.

6. Read the time-resolved fluorescence at the donor and acceptor emission wavelengths using a TR-FRET-compatible plate reader.
7. Calculate the TR-FRET ratio and determine the EC50.

Principle: SPR is a label-free technique that measures changes in the refractive index at the surface of a sensor chip upon binding of an analyte to an immobilized ligand. In this case,  $\beta$ -TrCP is immobilized, and the binding of  $\beta$ -catenin in the presence of **NRX-1532** is monitored in real-time.

Protocol:

- Reagents and Equipment:
  - Purified  $\beta$ -TrCP and  $\beta$ -catenin.
  - **NRX-1532**.
  - SPR sensor chip (e.g., CM5).
  - Amine coupling kit for immobilization.
  - Running buffer (e.g., HBS-EP+).
  - SPR instrument.
- Procedure:
  1. Immobilize  $\beta$ -TrCP onto the sensor chip surface via amine coupling.
  2. Prepare a series of  $\beta$ -catenin concentrations in running buffer, each with a constant concentration of **NRX-1532** or DMSO.
  3. Inject the  $\beta$ -catenin solutions over the sensor surface and monitor the binding response.
  4. Regenerate the sensor surface between injections.

- Analyze the sensorgrams to determine association and dissociation rate constants, and calculate the binding affinity (Kd).

## In Vitro Ubiquitination Assay

Principle: This assay reconstitutes the ubiquitination cascade in vitro to directly assess the ability of **NRX-1532** to enhance the ubiquitination of  $\beta$ -catenin by the SCF( $\beta$ -TrCP) complex.

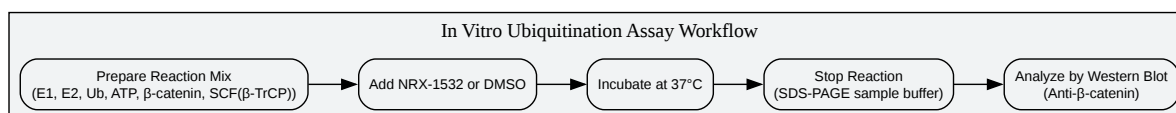

[Click to download full resolution via product page](#)

**Figure 3:** In Vitro Ubiquitination Assay Workflow.

Protocol:

- Reagents:
  - Recombinant E1 activating enzyme, E2 conjugating enzyme (e.g., UbcH5a), and Ubiquitin.
  - Recombinant SCF( $\beta$ -TrCP) complex.
  - Recombinant  $\beta$ -catenin (mutant form).
  - **NRX-1532**.
  - ATP.
  - Ubiquitination reaction buffer.
- Procedure:
  1. Combine E1, E2, ubiquitin, ATP, and  $\beta$ -catenin in the reaction buffer.

2. Add the SCF( $\beta$ -TrCP) complex.
3. Add **NRX-1532** or DMSO.
4. Incubate the reaction at 37°C for a specified time course (e.g., 0, 15, 30, 60 minutes).
5. Stop the reaction by adding SDS-PAGE sample buffer and boiling.
6. Analyze the samples by SDS-PAGE and Western blot using an anti- $\beta$ -catenin antibody to visualize the formation of polyubiquitinated  $\beta$ -catenin ladders.

## Cellular Assays

These assays evaluate the effects of **NRX-1532** in a cellular context. The SW480 colorectal cancer cell line, which harbors a mutation in APC leading to  $\beta$ -catenin stabilization, is a suitable model.<sup>[9][10]</sup>

Principle: This assay measures the levels of  $\beta$ -catenin protein in cells treated with **NRX-1532** to confirm its ability to induce degradation.

Protocol:

- Cell Culture:
  - Culture SW480 cells in appropriate media and conditions.
- Treatment:
  - Seed cells in 6-well plates and allow them to adhere overnight.
  - Treat cells with increasing concentrations of **NRX-1532** or DMSO for a specified time (e.g., 24 hours).
- Lysis and Protein Quantification:
  - Wash cells with PBS and lyse them in RIPA buffer containing protease inhibitors.
  - Quantify protein concentration using a BCA assay.

- Western Blot:
  - Separate equal amounts of protein lysate by SDS-PAGE and transfer to a PVDF membrane.
  - Block the membrane and incubate with a primary antibody against  $\beta$ -catenin.
  - Incubate with an HRP-conjugated secondary antibody.
  - Detect the signal using an enhanced chemiluminescence (ECL) substrate.
  - Use a loading control (e.g., GAPDH or  $\beta$ -actin) to normalize protein levels.

Principle: This colorimetric assay assesses cell metabolic activity as an indicator of cell viability. A reduction in viability upon treatment with **NRX-1532** would suggest a cytotoxic or cytostatic effect, likely due to the degradation of oncogenic  $\beta$ -catenin.

Protocol:

- Cell Seeding:
  - Seed SW480 cells in a 96-well plate.
- Treatment:
  - Treat cells with a serial dilution of **NRX-1532** for 24, 48, or 72 hours.
- MTT Addition:
  - Add MTT solution to each well and incubate for 2-4 hours at 37°C to allow the formation of formazan crystals.
- Solubilization:
  - Add a solubilization solution (e.g., DMSO or a specialized reagent) to dissolve the formazan crystals.
- Absorbance Reading:

- Measure the absorbance at a specific wavelength (e.g., 570 nm) using a microplate reader.
- Data Analysis:
  - Calculate the percentage of cell viability relative to the vehicle-treated control and determine the IC50 value.

Principle: This assay measures the mRNA levels of  $\beta$ -catenin target genes (e.g., c-myc, cyclin D1) to determine if **NRX-1532**-mediated degradation of  $\beta$ -catenin leads to a downstream decrease in its transcriptional activity.

Protocol:

- Cell Treatment and RNA Extraction:
  - Treat SW480 cells with **NRX-1532** as described for the Western blot assay.
  - Extract total RNA from the cells using a suitable kit.
- cDNA Synthesis:
  - Synthesize cDNA from the extracted RNA using a reverse transcription kit.
- Quantitative PCR:
  - Perform real-time PCR using SYBR Green or TaqMan probes for the target genes and a housekeeping gene (e.g., GAPDH).
- Data Analysis:
  - Analyze the relative gene expression using the  $\Delta\Delta C_t$  method.

## Conclusion

The protocols outlined in these application notes provide a comprehensive framework for the *in vitro* characterization of **NRX-1532**. These assays will enable researchers to confirm its mechanism of action as a molecular glue that enhances the  $\beta$ -catenin: $\beta$ -TrCP interaction,

leading to the degradation of mutant  $\beta$ -catenin and the subsequent inhibition of the Wnt signaling pathway in cancer cells.

### Need Custom Synthesis?

BenchChem offers custom synthesis for rare earth carbides and specific isotopic labeling.

Email: [info@benchchem.com](mailto:info@benchchem.com) or [Request Quote Online](#).

## References

- 1. Prospective discovery of small molecule enhancers of an E3 ligase-substrate interaction - PMC [[pmc.ncbi.nlm.nih.gov](https://pubmed.ncbi.nlm.nih.gov)]
- 2. Prospective discovery of small molecule enhancers of an E3 ligase-substrate interaction - PubMed [[pubmed.ncbi.nlm.nih.gov](https://pubmed.ncbi.nlm.nih.gov)]
- 3. Frontiers | Multiple Targets of the Canonical WNT/ $\beta$ -Catenin Signaling in Cancers [[frontiersin.org](https://frontiersin.org)]
- 4. WNT/ $\beta$ -catenin Signaling Pathway and Downstream Modulators in Low- and High-grade Glioma | Cancer Genomics & Proteomics [[cgp.iiarjournals.org](https://cgp.iiarjournals.org)]
- 5. Direct Targeting of  $\beta$ -Catenin in the Wnt Signaling Pathway: Current Progress and Perspectives - PMC [[pmc.ncbi.nlm.nih.gov](https://pubmed.ncbi.nlm.nih.gov)]
- 6. [researchgate.net](https://researchgate.net) [[researchgate.net](https://researchgate.net)]
- 7. [geneglobe.qiagen.com](https://geneglobe.qiagen.com) [[geneglobe.qiagen.com](https://geneglobe.qiagen.com)]
- 8. [researchgate.net](https://researchgate.net) [[researchgate.net](https://researchgate.net)]
- 9. [research.nu.edu.kz](https://research.nu.edu.kz) [[research.nu.edu.kz](https://research.nu.edu.kz)]
- 10. Targeted  $\beta$ -catenin ubiquitination and degradation by multifunctional stapled peptides - PubMed [[pubmed.ncbi.nlm.nih.gov](https://pubmed.ncbi.nlm.nih.gov)]
- To cite this document: BenchChem. [Application Notes and Protocols for NRX-1532 In Vitro Cell-Based Assays]. BenchChem, [2026]. [Online PDF]. Available at: [<https://www.benchchem.com/product/b7539272/docs#application-notes-and-protocols-for-nrx-1532-in-vitro-cell-based-assays>]

---

### Disclaimer & Data Validity:

The information provided in this document is for Research Use Only (RUO) and is strictly not intended for diagnostic or therapeutic procedures. While BenchChem strives to provide accurate protocols, we make no warranties, express or implied, regarding the fitness of this product for every specific experimental setup.

**Technical Support:** The protocols provided are for reference purposes. Unsure if this reagent suits your experiment?

**Need Industrial/Bulk Grade?** [Request Custom Synthesis Quote](#)

## BenchChem

Our mission is to be the trusted global source of essential and advanced chemicals, empowering scientists and researchers to drive progress in science and industry.

### Contact

Address: 3281 E Guasti Rd  
Ontario, CA 91761, United States  
Phone: (601) 213-4426  
Email: [info@benchchem.com](mailto:info@benchchem.com)

[Contact our Ph.D. Support Team for a compatibility check](#)