

Synthesis of N-cyclopropyl-2-methylbenzamide: A Detailed Application Note and Protocol

Author: BenchChem Technical Support Team. **Date:** April 2026

Compound of Interest

Compound Name: *N-cyclopropyl-2-methylbenzamide*

Cat. No.: *B7485909*

[Get Quote](#)

Abstract

This comprehensive guide details the synthesis of **N-cyclopropyl-2-methylbenzamide**, a valuable amide for research and development in medicinal chemistry and drug discovery. We present two robust and validated protocols for the synthesis of this target molecule: the acyl chloride method and a direct coupling approach using 1-Ethyl-3-(3-dimethylaminopropyl)carbodiimide (EDC) and Hydroxybenzotriazole (HOBt). This document provides in-depth procedural instructions, mechanistic insights, safety protocols, and detailed characterization guidelines to ensure reproducible and high-purity synthesis. The protocols are designed to be self-validating, with clear benchmarks for success at each stage.

Introduction

N-substituted benzamides are a prominent class of compounds in pharmaceutical and agrochemical research, exhibiting a wide range of biological activities. The incorporation of a cyclopropyl moiety can introduce unique conformational constraints and metabolic stability, making **N-cyclopropyl-2-methylbenzamide** a compound of significant interest for lead optimization and structure-activity relationship (SAR) studies.

The primary challenge in the synthesis of amides from carboxylic acids and amines is the unfavorable direct reaction, which typically results in the formation of a stable ammonium carboxylate salt.[1] To overcome this, the carboxylic acid must be "activated" to a more electrophilic species. This guide provides two effective methods for this activation and subsequent amidation.

Reaction Scheme

The overall transformation involves the formation of an amide bond between 2-methylbenzoic acid and cyclopropylamine.

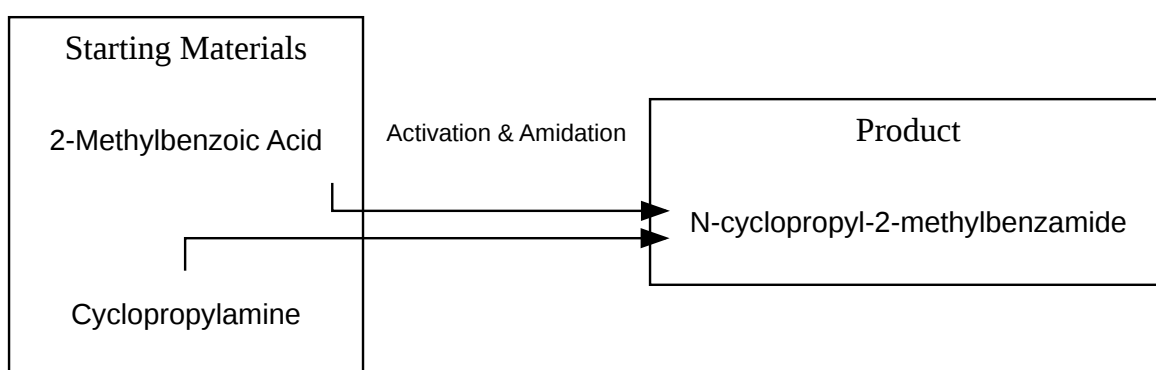

[Click to download full resolution via product page](#)

Caption: General reaction scheme for the synthesis of **N-cyclopropyl-2-methylbenzamide**.

Materials and Equipment

| Reagent/Material | Grade | Supplier |
|---|---------------------|-------------------|
| 2-Methylbenzoic Acid | ≥98% | Sigma-Aldrich |
| Cyclopropylamine | ≥98% | Sigma-Aldrich |
| Thionyl chloride (SOCl ₂) | Reagent grade, ≥99% | Sigma-Aldrich |
| 1-Ethyl-3-(3-dimethylaminopropyl)carbodiimide (EDC) | ≥98% | Sigma-Aldrich |
| Hydroxybenzotriazole (HOBT) | Anhydrous, ≥97% | Sigma-Aldrich |
| Triethylamine (TEA) | ≥99.5%, distilled | Sigma-Aldrich |
| Dichloromethane (DCM) | Anhydrous, ≥99.8% | Sigma-Aldrich |
| Toluene | Anhydrous, ≥99.8% | Sigma-Aldrich |
| Diethyl ether | Anhydrous, ≥99.7% | Sigma-Aldrich |
| Saturated sodium bicarbonate solution | ACS reagent | Fisher Scientific |
| Brine (Saturated NaCl solution) | ACS reagent | Fisher Scientific |
| Anhydrous magnesium sulfate (MgSO ₄) | ACS reagent | Fisher Scientific |
| Silica gel | 60 Å, 230-400 mesh | Sigma-Aldrich |

Equipment:

- Round-bottom flasks
- Reflux condenser
- Magnetic stirrer with heating plate
- Dropping funnel
- Ice bath

- Rotary evaporator
- Separatory funnel
- Glassware for column chromatography
- Standard laboratory glassware
- Fume hood
- Personal Protective Equipment (PPE): safety goggles, lab coat, chemically resistant gloves.

Detailed Synthesis Protocols

Two primary methods are presented. The choice of method may depend on the scale of the reaction, available reagents, and desired purity profile.

Method A: Acyl Chloride Formation Followed by Amidation

This two-step, one-pot procedure is a classic and highly effective method for amide synthesis. [2][3][4] It involves the conversion of the carboxylic acid to a more reactive acyl chloride using thionyl chloride, followed by the addition of the amine.

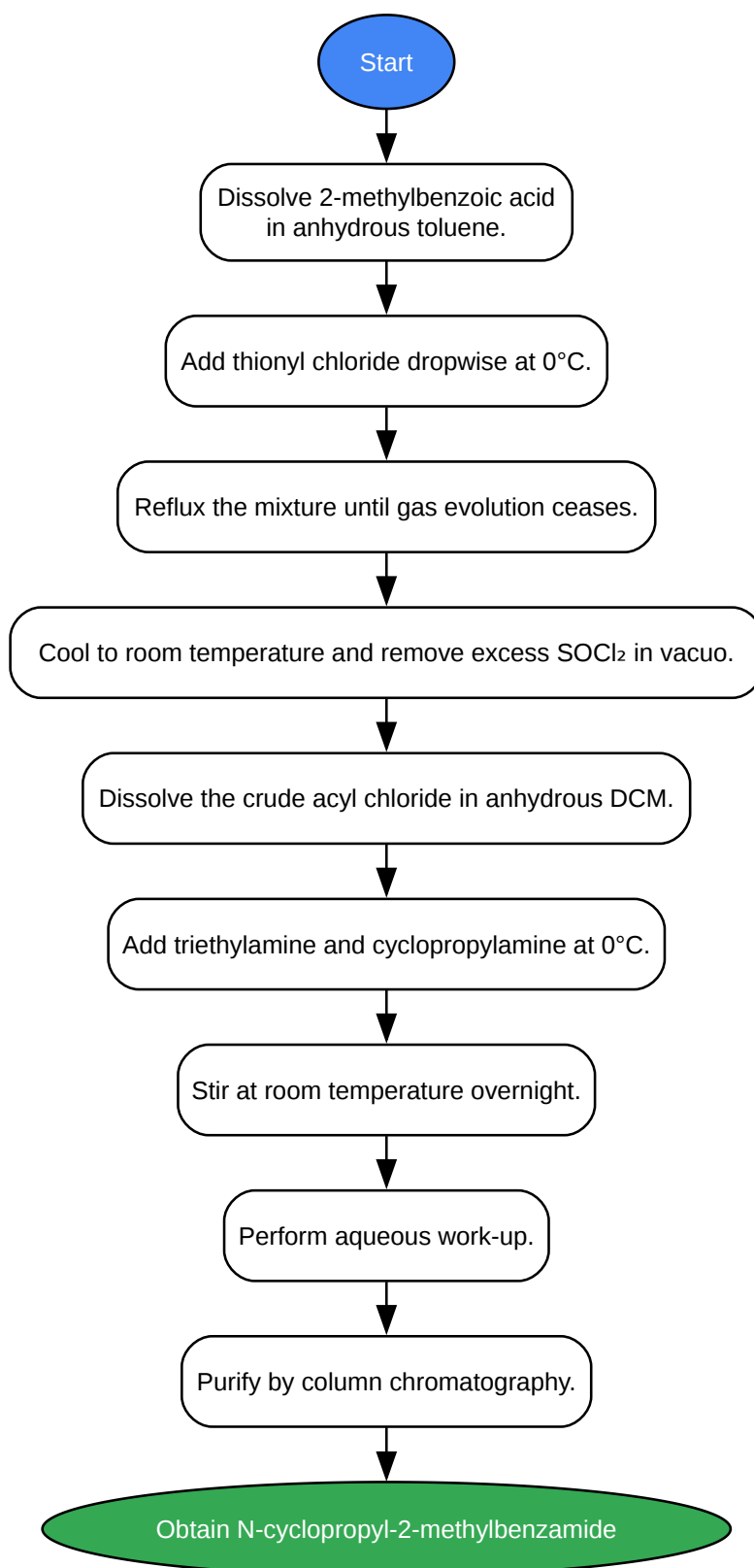

[Click to download full resolution via product page](#)

Caption: Workflow for the synthesis via the acyl chloride method.

Step-by-Step Protocol:

- Acyl Chloride Formation:
 - To a flame-dried 100 mL round-bottom flask equipped with a magnetic stir bar and a reflux condenser under an inert atmosphere (e.g., nitrogen or argon), add 2-methylbenzoic acid (5.0 g, 36.7 mmol).
 - Add 30 mL of anhydrous toluene.
 - Cool the mixture to 0 °C in an ice bath.
 - Slowly add thionyl chloride (4.0 mL, 55.1 mmol, 1.5 eq) dropwise via a syringe or dropping funnel over 15 minutes. Caution: This reaction is exothermic and releases HCl and SO₂ gas. Perform this step in a well-ventilated fume hood.
 - After the addition is complete, remove the ice bath and heat the reaction mixture to reflux (approximately 110 °C) for 2 hours. The reaction progress can be monitored by the cessation of gas evolution.
 - Cool the reaction mixture to room temperature.
 - Carefully remove the solvent and excess thionyl chloride under reduced pressure using a rotary evaporator. The resulting residue is crude 2-methylbenzoyl chloride.
- Amidation:
 - Dissolve the crude 2-methylbenzoyl chloride in 40 mL of anhydrous dichloromethane (DCM) and cool the solution to 0 °C in an ice bath.
 - In a separate flask, prepare a solution of cyclopropylamine (3.1 mL, 44.0 mmol, 1.2 eq) and triethylamine (7.7 mL, 55.1 mmol, 1.5 eq) in 20 mL of anhydrous DCM.
 - Add the amine solution dropwise to the stirred acyl chloride solution over 30 minutes, maintaining the temperature at 0 °C.
 - After the addition is complete, remove the ice bath and allow the reaction to warm to room temperature. Stir overnight (12-16 hours).

- Monitor the reaction progress by Thin Layer Chromatography (TLC).
- Work-up and Purification:
 - Transfer the reaction mixture to a separatory funnel.
 - Wash the organic layer sequentially with 50 mL of 1 M HCl, 50 mL of saturated aqueous sodium bicarbonate solution, and 50 mL of brine.
 - Dry the organic layer over anhydrous magnesium sulfate, filter, and concentrate under reduced pressure to obtain the crude product.
 - Purify the crude product by flash column chromatography on silica gel, eluting with a gradient of ethyl acetate in hexanes (e.g., 10% to 40% ethyl acetate).
 - Combine the fractions containing the pure product and remove the solvent under reduced pressure to yield **N-cyclopropyl-2-methylbenzamide** as a solid.

Method B: EDC/HOBt Coupling

This method utilizes a carbodiimide coupling agent (EDC) in the presence of an additive (HOBt) to facilitate amide bond formation under milder conditions than the acyl chloride method.^{[5][6]}

This is often preferred for substrates with sensitive functional groups.

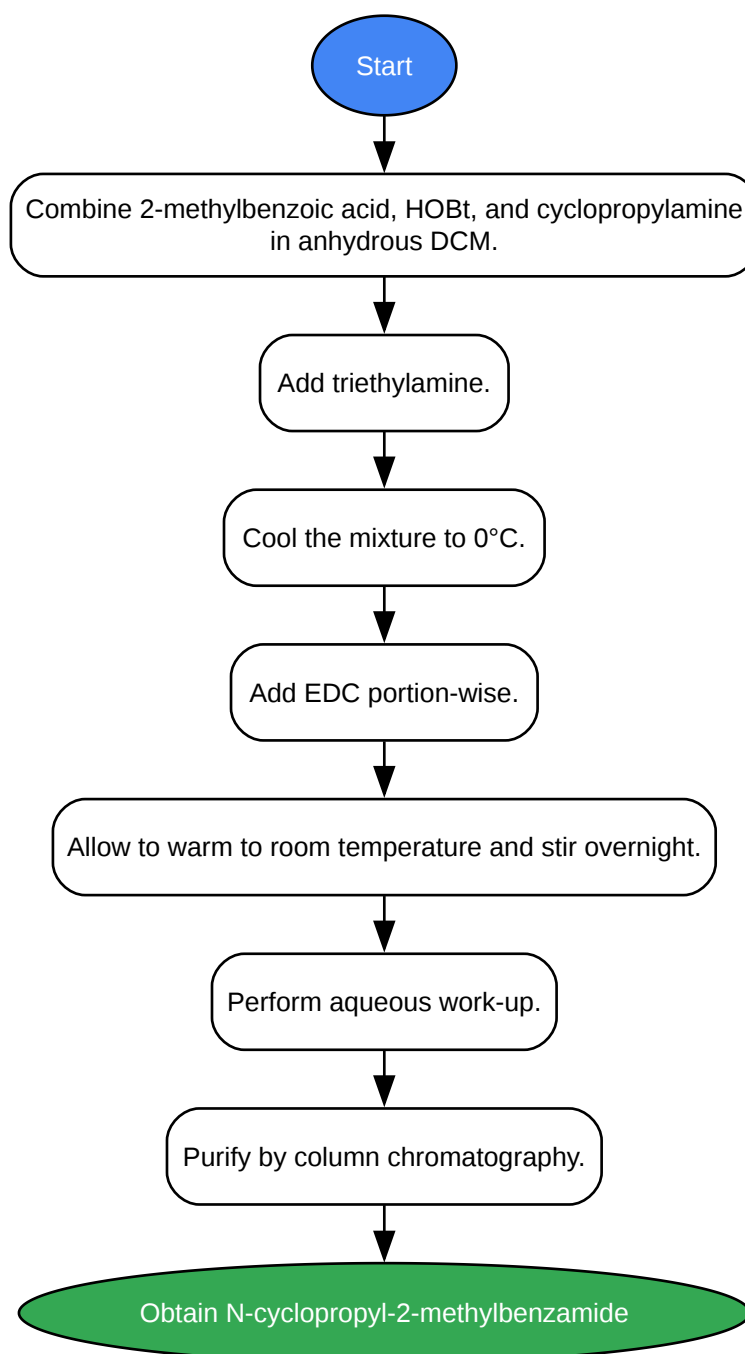

[Click to download full resolution via product page](#)

Caption: Workflow for the synthesis using EDC/HOBt coupling.

Step-by-Step Protocol:

- Reaction Setup:

- To a 100 mL round-bottom flask equipped with a magnetic stir bar under an inert atmosphere, add 2-methylbenzoic acid (5.0 g, 36.7 mmol), HOBT (5.4 g, 40.4 mmol, 1.1 eq), and cyclopropylamine (2.8 mL, 40.4 mmol, 1.1 eq).
- Add 50 mL of anhydrous dichloromethane (DCM).
- Add triethylamine (10.2 mL, 73.4 mmol, 2.0 eq) and stir the mixture until all solids are dissolved.
- Cool the reaction mixture to 0 °C in an ice bath.
- Coupling Reaction:
 - Slowly add EDC hydrochloride (7.7 g, 40.4 mmol, 1.1 eq) portion-wise over 15 minutes to the cold, stirred reaction mixture.
 - After the addition is complete, allow the reaction to slowly warm to room temperature and stir overnight (12-18 hours).
 - Monitor the reaction progress by TLC.
- Work-up and Purification:
 - Dilute the reaction mixture with an additional 50 mL of DCM.
 - Transfer the mixture to a separatory funnel.
 - Wash the organic layer sequentially with 50 mL of 1 M HCl, 50 mL of saturated aqueous sodium bicarbonate solution, and 50 mL of brine.
 - Dry the organic layer over anhydrous magnesium sulfate, filter, and concentrate under reduced pressure.
 - Purify the crude product by flash column chromatography on silica gel using a gradient of ethyl acetate in hexanes.
 - Combine the pure fractions and remove the solvent under reduced pressure to yield **N-cyclopropyl-2-methylbenzamide**.

Characterization of N-cyclopropyl-2-methylbenzamide

As a self-validating system, it is crucial to confirm the identity and purity of the synthesized product. The following are the expected analytical data based on the structure and data from analogous compounds.

| Property | Value |
|-------------------|--|
| Molecular Formula | C ₁₁ H ₁₃ NO |
| Molecular Weight | 175.23 g/mol |
| CAS Number | 574718-63-1 |
| Appearance | Expected to be a white to off-white solid. |

Nuclear Magnetic Resonance (NMR) Spectroscopy

- ¹H NMR (400 MHz, CDCl₃): The spectrum is expected to show signals for the aromatic protons of the 2-methylphenyl group, a singlet for the methyl group, and signals for the cyclopropyl ring protons.
 - Aromatic protons: Multiplets in the range of δ 7.1-7.4 ppm (4H).
 - NH proton: A broad singlet around δ 6.0-6.5 ppm (1H).
 - Methyl protons: A singlet around δ 2.4 ppm (3H).
 - Cyclopropyl CH proton: A multiplet around δ 2.8-2.9 ppm (1H).
 - Cyclopropyl CH₂ protons: Multiplets in the upfield region, expected around δ 0.8-0.9 ppm (2H) and δ 0.5-0.6 ppm (2H), due to the ring's magnetic anisotropy.[7]
- ¹³C NMR (100 MHz, CDCl₃): The spectrum should show distinct signals for the carbonyl carbon, the aromatic carbons, the methyl carbon, and the carbons of the cyclopropyl ring.
 - Carbonyl carbon (C=O): Expected around δ 168-170 ppm.

- Aromatic carbons: Signals in the range of δ 125-138 ppm.
- Methyl carbon: A signal around δ 19-21 ppm.
- Cyclopropyl CH carbon: Expected around δ 22-24 ppm.
- Cyclopropyl CH₂ carbons: Signals in the upfield region, typically around δ 6-8 ppm.[7]

Infrared (IR) Spectroscopy

The IR spectrum should exhibit characteristic absorption bands for the amide functional group and the aromatic ring.

- N-H stretch: A sharp to moderately broad peak around 3300-3250 cm⁻¹.
- C-H stretch (aromatic): Peaks just above 3000 cm⁻¹.
- C-H stretch (aliphatic): Peaks just below 3000 cm⁻¹.
- C=O stretch (Amide I band): A strong, sharp absorption around 1640-1630 cm⁻¹.
- N-H bend (Amide II band): A peak around 1550-1540 cm⁻¹.

Mass Spectrometry (MS)

- Electron Impact (EI-MS): The mass spectrum should show a molecular ion peak (M⁺) at m/z = 175. The fragmentation pattern would likely involve cleavage of the amide bond and fragmentation of the side chains.

Safety and Handling

- General Precautions: All manipulations should be performed in a well-ventilated fume hood. Wear appropriate personal protective equipment (PPE), including safety glasses, a lab coat, and chemical-resistant gloves.
- Thionyl Chloride (SOCl₂): Highly corrosive and toxic. Reacts violently with water to release toxic gases (HCl and SO₂).^[8] Handle with extreme care under anhydrous conditions. Avoid inhalation of vapors and contact with skin and eyes.

- Cyclopropylamine: Flammable liquid and vapor. It is corrosive and can cause severe skin burns and eye damage. It is also harmful if swallowed or inhaled.
- EDC and HOBt: Can be irritating to the skin, eyes, and respiratory system. HOBt is also a potential explosion hazard when dry and should be handled with care.
- Waste Disposal: Dispose of all chemical waste in accordance with local, state, and federal regulations. Quench reactive reagents carefully before disposal.

Conclusion

The synthesis of **N-cyclopropyl-2-methylbenzamide** can be reliably achieved through either an acyl chloride intermediate or a direct EDC/HOBt coupling protocol. Both methods offer good yields and produce a high-purity product after standard purification techniques. The choice of method will depend on the specific laboratory setup and substrate sensitivities. The provided characterization data, based on established principles of spectroscopy, will serve as a crucial tool for researchers to verify the successful synthesis of the target compound. This detailed guide provides the necessary framework for the safe and reproducible synthesis of **N-cyclopropyl-2-methylbenzamide** for applications in chemical and pharmaceutical research.

References

- Carl ROTH. (2024). Safety Data Sheet: Thionyl chloride.
- ResearchGate. (2012, October 12). How to produce amide from Benzoic acid and amine directly?
- BenchChem. (n.d.). N-(2-methylpropyl)benzamide: A Technical Guide.
- New Jersey Department of Health. (n.d.). Hazard Summary: Thionyl Chloride.
- Costantino, C., et al. (2017).
- Fisher Scientific. (n.d.). Amide Synthesis.
- ResearchGate. (2011, April 4). Correlation analysis of IR, 1H and 13C NMR spectral data of N-alkyl and N-cycloalkyl cyanoacetamides.
- Lebedev, A. T., et al. (2001, August 15). Cyclization of ortho-cyclopropylphenyl benzamides in gas and liquid phases. PubMed.
- Peptides. (n.d.). Standard Coupling Procedures; DIC/HOBt; PyBOP; HBTU; PyBrOP.
- FUJIFILM Wako. (n.d.). Safety Data Sheet: Thionyl Chloride.
- Sigma-Aldrich. (2013, March 19). Thionyl chloride - Safety Data Sheet.
- BenchChem. (n.d.). A Comparative Guide to the 1H and 13C NMR Spectral Analysis of Cyclopropylbenzene Derivatives.

- Sharma, S., et al. (n.d.). Synthesis of amide derivatives for electron deficient amines and functionalized carboxylic acids using EDC and DMAP and a catalytic amount of HOBT as the coupling reagents. PMC.
- Chemistry Steps. (2025, November 29). Amides from Carboxylic Acids-DCC and EDC Coupling.
- Valeur, E., & Bradley, M. (2008, June 23). Amide bond formation: beyond the myth of coupling reagents. Luxembourg Bio Technologies.
- BenchChem. (n.d.). Application Notes and Protocols for the Synthesis of Amides from 6-Bromo-3-methoxy-2-methylbenzoic acid.

Need Custom Synthesis?

BenchChem offers custom synthesis for rare earth carbides and specific isotopic labeling.

Email: info@benchchem.com or [Request Quote Online](#).

Sources

- 1. Benzamide, N-[2-(cyclopropylmethyl)-5-(1,1-dimethylethyl)-1,2-dihydro-1-methyl-3H-pyrazol-3-ylidene]-2-fluoro-3-(trifluoromethyl)- | C₂₀H₂₃F₄N₃O | CID 24763642 - PubChem [pubchem.ncbi.nlm.nih.gov]
- 2. spectrabase.com [spectrabase.com]
- 3. researchgate.net [researchgate.net]
- 4. N-cyclopropyl-N-methyl-benzamide - Chemical & Physical Properties by Cheméo [cheméo.com]
- 5. Benzamide, N-methyl- [webbook.nist.gov]
- 6. N-(2-Methylpropyl)benzamide | C₁₁H₁₅NO | CID 95140 - PubChem [pubchem.ncbi.nlm.nih.gov]
- 7. N-cyclopropyl-2-methylbenzamide,574718-63-1-Shanghai Chemlin-Shanghai Chemlin [shachemlin.com]
- 8. spectrabase.com [spectrabase.com]
- To cite this document: BenchChem. [Synthesis of N-cyclopropyl-2-methylbenzamide: A Detailed Application Note and Protocol]. BenchChem, [2026]. [Online PDF]. Available at: [<https://www.benchchem.com/product/b7485909/docs#synthesis-of-n-cyclopropyl-2-methylbenzamide-a-detailed-application-note-and-protocol>]

Disclaimer & Data Validity:

The information provided in this document is for Research Use Only (RUO) and is strictly not intended for diagnostic or therapeutic procedures. While BenchChem strives to provide accurate protocols, we make no warranties, express or implied, regarding the fitness of this product for every specific experimental setup.

Technical Support: The protocols provided are for reference purposes. Unsure if this reagent suits your experiment?

Need Industrial/Bulk Grade? [Request Custom Synthesis Quote](#)

BenchChem

Our mission is to be the trusted global source of essential and advanced chemicals, empowering scientists and researchers to drive progress in science and industry.

Contact

Address: 3281 E Guasti Rd
Ontario, CA 91761, United States
Phone: (601) 213-4426
Email: info@benchchem.com

[Contact our Ph.D. Support Team for a compatibility check](#)