

Application Notes and Protocols for Photocatalytic Zinc-Based Heterostructures

Author: BenchChem Technical Support Team. **Date:** April 2026

Compound of Interest

Compound Name: Zinc nitride

CAS No.: 1313-49-1

Cat. No.: B074714

[Get Quote](#)

A Note on Material Focus: While the topic of interest is **zinc nitride** (Zn_3N_2) heterostructures, a comprehensive review of current scientific literature reveals a notable scarcity of research specifically focused on the photocatalytic applications of Zn_3N_2 -based heterostructures. This is largely attributed to challenges in the synthesis and stability of **zinc nitride**, which readily oxidizes to zinc oxide (ZnO) under ambient conditions[1]. However, the intrinsic direct bandgap of Zn_3N_2 (in the range of 0.9-1.48 eV) suggests its potential for visible-light-driven applications[1][2].

In contrast, the field of photocatalysis is rich with studies on heterostructures combining zinc oxide (ZnO) with graphitic carbon nitride (g- C_3N_4), a nitrogen-rich polymer. These ZnO/g- C_3N_4 heterostructures have demonstrated significant promise in various photocatalytic applications. Therefore, these application notes will focus on ZnO/g- C_3N_4 and related zinc-based heterostructures as a highly relevant and well-documented alternative.

Introduction to Zinc-Based Photocatalytic Heterostructures

Zinc-based semiconductor heterostructures, particularly those involving zinc oxide (ZnO) and graphitic carbon nitride (g-C₃N₄), are at the forefront of photocatalysis research. These materials are lauded for their efficacy in degrading organic pollutants, producing hydrogen through water splitting, and reducing carbon dioxide into valuable fuels[3][4][5]. The enhanced photocatalytic activity of these heterostructures stems from the synergistic effects at the interface of the two semiconductor materials, which promotes efficient separation of photogenerated electron-hole pairs and extends the light absorption range[3][6].

The construction of heterojunctions, such as Type-II, Z-scheme, or S-scheme, dictates the charge transfer pathway and, consequently, the redox capabilities of the photocatalyst[3][7]. These advanced structures are designed to maximize the lifetime of charge carriers and enhance their reductive and oxidative power for various chemical transformations.

Applications and Performance Data

The applications of zinc-based heterostructures in photocatalysis are diverse, with significant potential in environmental remediation and renewable energy production. The performance of these materials is typically evaluated based on metrics such as the degradation rate of pollutants, the rate of hydrogen evolution, or the yield of CO₂ reduction products.

Table 1: Photocatalytic Degradation of Organic Pollutants

Heterostructure	Target Pollutant	Light Source	Degradation Efficiency (%)	Time (min)	Reference
ZnO/g-C ₃ N ₄	Methylene Blue	Visible Light	98.54	70	[4]
ZnO/g-C ₃ N ₄	Amiloride	Fluorescent Light	~53	Not Specified	[1][4]
ZnO/Fe ₂ O ₃ /g-C ₃ N ₄ -10%	Sulfonamides	Visible Light	>90	Not Specified	[3]
g-C ₃ N ₄ /ZnO	Phenol	Visible Light	~1.15x higher than pure g-C ₃ N ₄	Not Specified	[6]
g-C ₃ N ₄ /ZnO	Phenol	UV Light	~2.6x higher than pure g-C ₃ N ₄	Not Specified	[6]

Table 2: Photocatalytic Hydrogen Production

Heterostructure	Sacrificial Agent	Light Source	H ₂ Evolution Rate (μmol·h ⁻¹ ·g ⁻¹)	Reference
g-C ₃ N ₄ @ZnIn ₂ S ₄	Triethanolamine (TEOA)	Visible Light	228.6x higher than pure g-C ₃ N ₄	[5]
ZnS/ZnO/g-C ₃ N ₄	Na ₂ S/Na ₂ SO ₃	UV Light	2548	[3]

 Table 3: Photocatalytic CO₂ Reduction

Heterostructure	Products	Light Source	Yield ($\mu\text{mol}\cdot\text{g}^{-1}$)	Time (h)	Reference
ZnO/ZnIn ₂ S ₄ (S-scheme)	CO	Visible Light	233	Not Specified	[8]
ZIS/HCNT (S-scheme)	CO	Not Specified	883	1	[9]
40-ZnO@ZIS (S-scheme)	CO, CH ₄	Not Specified	39.76 (CO), 3.92 (CH ₄)	1	[8]

Experimental Protocols

Detailed experimental protocols are crucial for the reproducible synthesis and evaluation of photocatalytic heterostructures. Below are representative protocols for the synthesis of ZnO/g-C₃N₄ heterostructures and the assessment of their photocatalytic activity.

Synthesis of g-C₃N₄/ZnO Nanorod Heterostructures

This protocol describes a method combining hydrothermal synthesis, grinding, and calcination[10].

Materials:

- Zinc acetate dihydrate ($\text{Zn}(\text{CH}_3\text{COO})_2\cdot 2\text{H}_2\text{O}$)
- Hexamethylenetetramine ($(\text{CH}_2)_6\text{N}_4$)
- Urea ($\text{CO}(\text{NH}_2)_2$)
- Deionized (DI) water
- Ethanol

Procedure:

- Synthesis of ZnO Nanorods:

- Dissolve equimolar amounts of zinc acetate dihydrate and hexamethylenetetramine in DI water.
- Transfer the solution to a Teflon-lined stainless-steel autoclave.
- Heat the autoclave at 95°C for 6 hours.
- Allow the autoclave to cool to room temperature naturally.
- Collect the white precipitate by centrifugation, wash thoroughly with DI water and ethanol, and dry at 60°C.
- Synthesis of g-C₃N₄:
 - Place a specific amount of urea in a crucible with a lid.
 - Heat the crucible in a muffle furnace at 550°C for 4 hours.
 - Allow the furnace to cool to room temperature.
 - Grind the resulting yellow agglomerate into a fine powder.
- Formation of g-C₃N₄/ZnO Heterostructure:
 - Disperse a desired weight ratio of the prepared ZnO nanorods and g-C₃N₄ powder in ethanol.
 - Sonically disperse the mixture for 1 hour.
 - Dry the mixture at 80°C to evaporate the ethanol.
 - Calcine the resulting powder at 400°C for 2 hours in a muffle furnace.

Photocatalytic Activity Evaluation: Degradation of Methylene Blue

This protocol outlines the procedure for assessing the photocatalytic degradation of an organic dye under visible light irradiation[4].

Materials:

- Synthesized g-C₃N₄/ZnO photocatalyst
- Methylene Blue (MB) solution (e.g., 20 mg/L)
- Visible light source (e.g., 300W Xenon lamp with a UV cutoff filter)
- Magnetic stirrer
- Spectrophotometer

Procedure:

- Adsorption-Desorption Equilibrium:
 - Disperse a specific amount of the photocatalyst (e.g., 50 mg) in a known volume of MB solution (e.g., 100 mL).
 - Stir the suspension in the dark for 30-60 minutes to establish adsorption-desorption equilibrium between the photocatalyst and the dye.
- Photocatalytic Reaction:
 - Expose the suspension to visible light irradiation while continuously stirring.
 - At regular time intervals (e.g., every 10 minutes), withdraw a small aliquot (e.g., 3 mL) of the suspension.
 - Centrifuge the aliquot to remove the photocatalyst particles.
- Concentration Measurement:
 - Measure the absorbance of the supernatant at the maximum absorption wavelength of MB (around 664 nm) using a spectrophotometer.
 - Calculate the concentration of MB using a pre-established calibration curve.
- Data Analysis:

- Calculate the degradation efficiency using the formula: $\text{Degradation (\%)} = [(C_0 - C_t) / C_0] \times 100$, where C_0 is the initial concentration of MB after adsorption-desorption equilibrium, and C_t is the concentration at time t .

Visualizing Reaction Mechanisms and Workflows

Understanding the underlying mechanisms of photocatalysis is essential for designing more efficient materials. Graphviz diagrams are provided below to illustrate a typical experimental workflow and the charge transfer mechanism in a Type-II heterojunction.

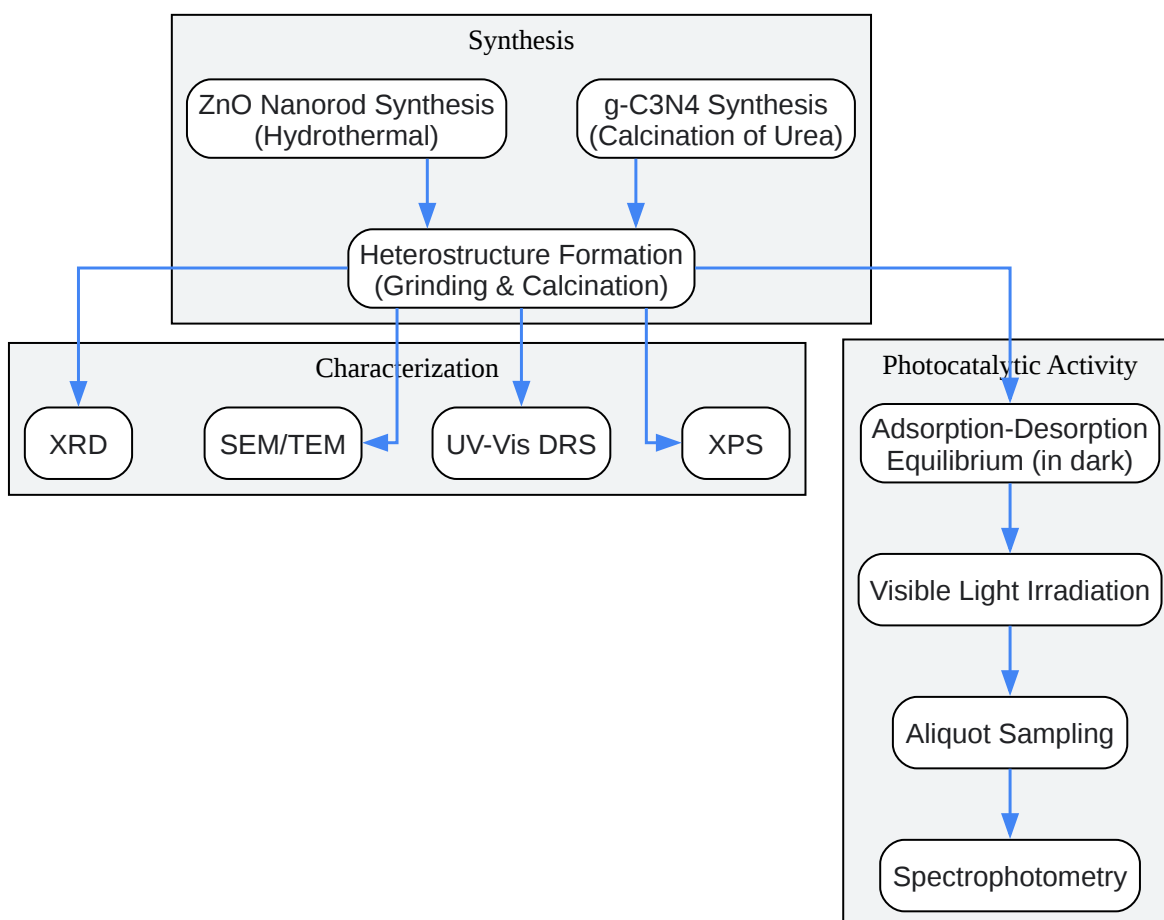

[Click to download full resolution via product page](#)

Caption: Experimental workflow for synthesis, characterization, and photocatalytic testing.

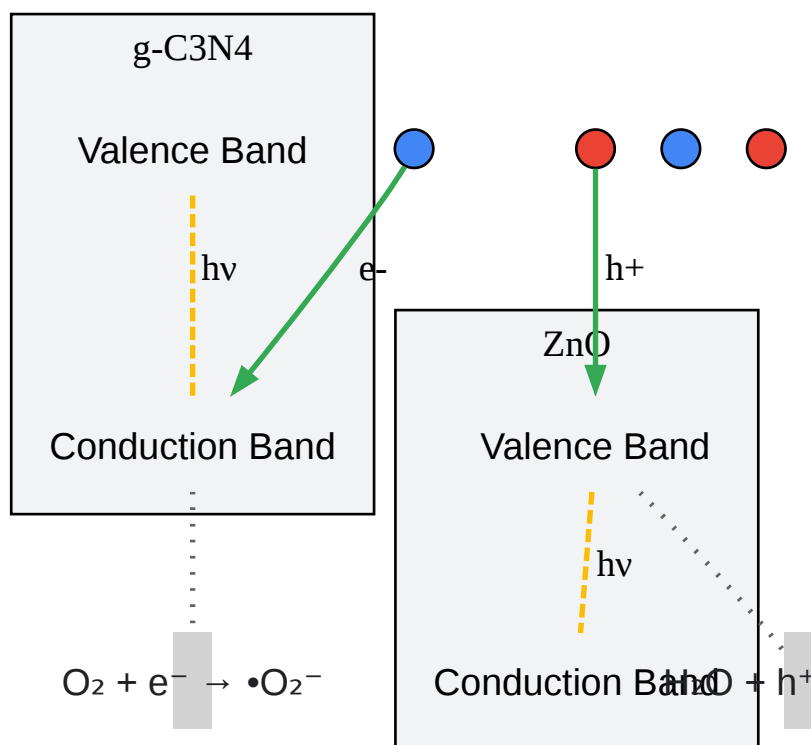

[Click to download full resolution via product page](#)

Caption: Charge transfer in a Type-II g-C₃N₄/ZnO heterojunction for photocatalysis.

Need Custom Synthesis?

BenchChem offers custom synthesis for rare earth carbides and specific isotopic labeling.

Email: info@benchchem.com or [Request Quote Online](#).

References

- 1. pubs.acs.org [pubs.acs.org]
- 2. Electronic structure and band alignment of zinc nitride, Zn₃N₂ - RSC Advances (RSC Publishing) [pubs.rsc.org]

- [3. mdpi.com \[mdpi.com\]](#)
- [4. cdmf.org.br \[cdmf.org.br\]](#)
- [5. mdpi.com \[mdpi.com\]](#)
- [6. Highly efficient zinc oxide-carbon nitride composite photocatalysts for degradation of phenol under UV and visible light irradiation | Malaysian Journal of Fundamental and Applied Sciences \[mjfas.utm.my\]](#)
- [7. mdpi.com \[mdpi.com\]](#)
- [8. researchgate.net \[researchgate.net\]](#)
- [9. researchgate.net \[researchgate.net\]](#)
- [10. researchgate.net \[researchgate.net\]](#)
- To cite this document: BenchChem. [Application Notes and Protocols for Photocatalytic Zinc-Based Heterostructures]. BenchChem, [2026]. [Online PDF]. Available at: [\[https://www.benchchem.com/product/b074714/docs#application-notes-and-protocols-for-photocatalytic-zinc-based-heterostructures\]](https://www.benchchem.com/product/b074714/docs#application-notes-and-protocols-for-photocatalytic-zinc-based-heterostructures)

Disclaimer & Data Validity:

The information provided in this document is for Research Use Only (RUO) and is strictly not intended for diagnostic or therapeutic procedures. While BenchChem strives to provide accurate protocols, we make no warranties, express or implied, regarding the fitness of this product for every specific experimental setup.

Technical Support: The protocols provided are for reference purposes. Unsure if this reagent suits your experiment?

Need Industrial/Bulk Grade? [Request Custom Synthesis Quote](#)

BenchChem

Our mission is to be the trusted global source of essential and advanced chemicals, empowering scientists and researchers to drive progress in science and industry.

Contact

Address: 3281 E Guasti Rd
Ontario, CA 91761, United States
Phone: (601) 213-4426
Email: info@benchchem.com

Contact our Ph.D. Support Team for a compatibility check