

A Comparative Analysis of Carboxylic Acid Acidity: The Case of 2-Cyclohexylideneacetic Acid

Author: BenchChem Technical Support Team. **Date:** January 2026

Compound of Interest

Compound Name: 2-Cyclohexylideneacetic acid

Cat. No.: B074993

[Get Quote](#)

This guide provides an in-depth comparison of the acidity of **2-Cyclohexylideneacetic acid** with other structurally diverse carboxylic acids. Tailored for researchers, scientists, and professionals in drug development, this document synthesizes theoretical principles with experimental data to offer a comprehensive understanding of the factors governing carboxylic acid pKa values.

Introduction: The Essence of Acidity in Carboxylic Acids

The acidity of a carboxylic acid, quantified by its acid dissociation constant (Ka) or, more conveniently, its pKa (-logKa), is a fundamental property that dictates its behavior in chemical and biological systems. A lower pKa value signifies a stronger acid, indicating a greater propensity to donate a proton (H+) in solution.[1] This dissociation equilibrium is profoundly influenced by the molecule's structure, specifically the stability of the resulting carboxylate anion.[2] Anything that stabilizes this conjugate base will increase the acidity of the parent carboxylic acid.[3] The primary factors at play are resonance and inductive effects.[4]

All carboxylic acids benefit from the resonance stabilization of their carboxylate anion, where the negative charge is delocalized across two oxygen atoms. This inherent stability is why carboxylic acids are significantly more acidic than alcohols.[2] However, the substituents

attached to the carboxylic acid moiety can dramatically modulate this acidity through inductive effects—the withdrawal or donation of electron density through sigma bonds.[4]

This guide will explore these principles by comparing **2-Cyclohexylideneacetic acid** to a series of aliphatic, unsaturated, and aromatic carboxylic acids.

Comparative Acidity: A Data-Driven Analysis

The acidity of **2-Cyclohexylideneacetic acid** is best understood when contextualized against other carboxylic acids. The following table summarizes the experimental pKa values for a selection of relevant compounds.

Carboxylic Acid	Structure	pKa Value
Acetic Acid	CH ₃ COOH	4.76[5]
Cyclohexylacetic Acid	C ₆ H ₁₁ CH ₂ COOH	4.51[6]
Cyclohexanecarboxylic Acid	C ₆ H ₁₁ COOH	4.90[5][7]
Acrylic Acid	CH ₂ =CHCOOH	4.25[8]
2-Cyclohexylideneacetic Acid	C ₆ H ₁₀ =CHCOOH	4.25 (Predicted)
Benzoic Acid	C ₆ H ₅ COOH	4.20[7]

Note: The pKa for **2-Cyclohexylideneacetic acid** is a predicted value. An exhaustive search of current literature did not yield a publicly available experimental value. The prediction is based on computational models that consider its structural similarity to other α,β -unsaturated acids.

Analysis of Structural Effects

The data in the table reveals distinct trends that can be rationalized by considering the electronic effects of the substituent groups.

- Alkyl Groups (Electron-Donating): Comparing Acetic Acid (pKa 4.76) to Cyclohexylacetic Acid (pKa 4.51) and Cyclohexanecarboxylic Acid (pKa 4.90) illustrates the impact of alkyl groups. Alkyl groups are weakly electron-donating.[3] This donation of electron density slightly destabilizes the carboxylate anion, making the acid weaker (higher pKa). The

cyclohexyl group in Cyclohexanecarboxylic acid is directly attached to the carboxyl group, leading to a more pronounced electron-donating effect compared to the methylene-insulated cyclohexyl group in Cyclohexylacetic acid, hence its higher pKa.

- **Unsaturation and Sp² Hybridization (Electron-Withdrawing):** The introduction of a carbon-carbon double bond (unsaturation) alpha and beta to the carboxylic acid group, as seen in Acrylic Acid (pKa 4.25) and **2-Cyclohexylideneacetic acid** (predicted pKa 4.25), significantly increases acidity compared to their saturated counterparts. This is due to the electron-withdrawing nature of the sp² hybridized carbons of the double bond.[9][10] The greater s-character of sp² orbitals compared to sp³ orbitals makes them more electronegative, pulling electron density away from the carboxylate anion and stabilizing it.[4]
- **Aromatic Rings (Electron-Withdrawing):** Benzoic Acid, with a pKa of 4.20, is a stronger acid than its saturated counterpart, Cyclohexanecarboxylic Acid (pKa 4.90).[7] The sp² hybridized carbons of the benzene ring act as an electron-withdrawing group, stabilizing the benzoate conjugate base.

The predicted pKa of 4.25 for **2-Cyclohexylideneacetic acid** places it in the same acidity range as acrylic acid and benzoic acid. This is logically consistent, as it possesses an α,β -unsaturated system, which is a key structural feature for enhanced acidity. The exocyclic double bond, with its sp² hybridized carbons, effectively withdraws electron density, thereby stabilizing the carboxylate anion.

The following diagram illustrates the interplay of these structural factors on the stability of the carboxylate anion.

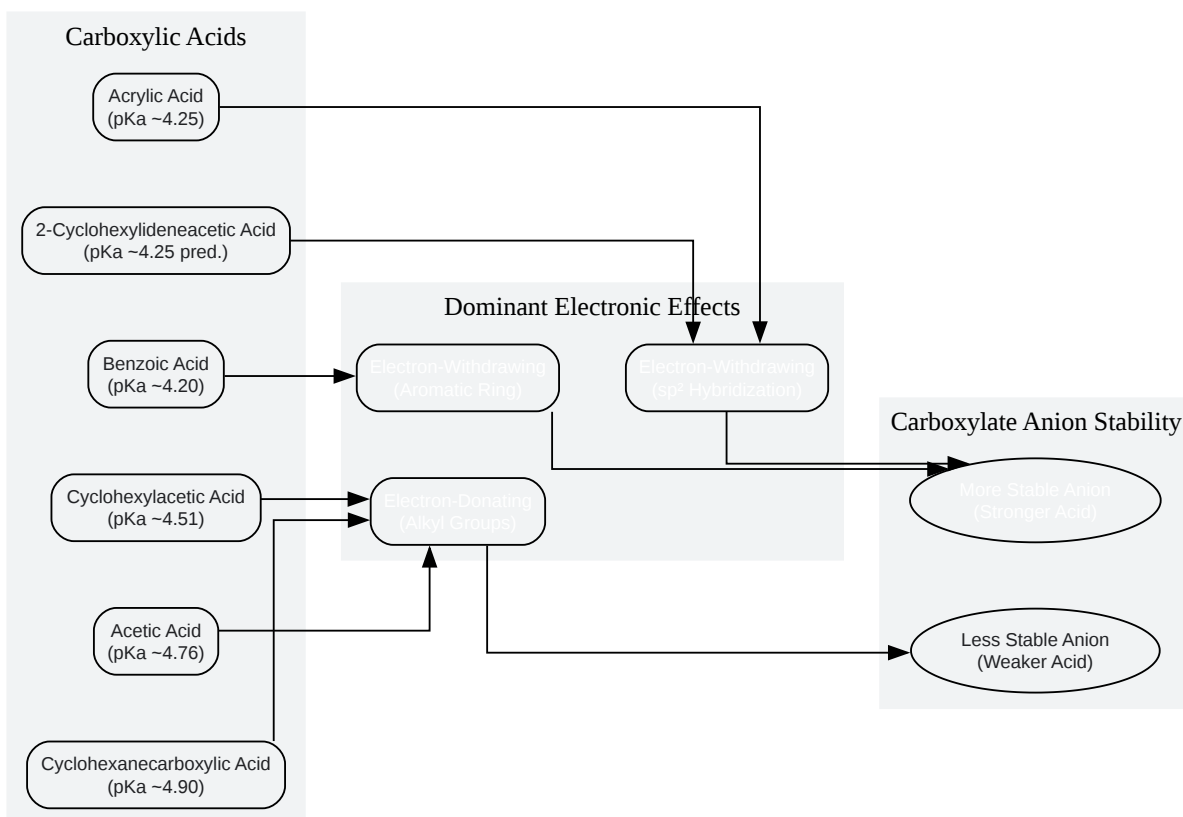

[Click to download full resolution via product page](#)

Caption: Relationship between electronic effects and acid strength.

Experimental Protocol: pKa Determination by Potentiometric Titration

To ensure scientific integrity, experimental determination of pKa is paramount. Potentiometric titration is a robust and widely accepted method for this purpose.[11][12] It involves monitoring the pH of a solution of the acid as a titrant of known concentration (typically a strong base like NaOH) is added. The pKa corresponds to the pH at the half-equivalence point.[1]

Materials and Reagents

- pH meter with a glass electrode, calibrated with standard buffers (pH 4.00, 7.00, and 10.00)
- Magnetic stirrer and stir bar
- Calibrated burette (25 mL or 50 mL)
- Volumetric flasks and pipettes
- Beakers
- Carboxylic acid sample (e.g., **2-Cyclohexylideneacetic acid**)
- Standardized 0.1 M Sodium Hydroxide (NaOH) solution (carbonate-free)
- Deionized, degassed water (to minimize CO₂ interference)
- 0.15 M Potassium Chloride (KCl) solution (to maintain constant ionic strength)

Step-by-Step Procedure

- Preparation of the Analyte Solution: Accurately weigh a sample of the carboxylic acid and dissolve it in a known volume of deionized, degassed water to prepare a solution of approximately 0.01 M. A co-solvent like methanol or ethanol may be used if the acid has low water solubility, but this will yield an apparent pKa (pKa*) specific to that solvent system.
- Titration Setup:
 - Pipette a precise volume (e.g., 25.00 mL) of the acid solution into a beaker.
 - Add a sufficient volume of 0.15 M KCl to maintain a constant ionic strength.
 - Place a magnetic stir bar in the beaker and place it on a magnetic stirrer.
 - Immerse the calibrated pH electrode in the solution, ensuring the bulb is fully submerged but not in the path of the stir bar.
- Titration:

- Record the initial pH of the solution.
- Begin adding the standardized 0.1 M NaOH solution from the burette in small increments (e.g., 0.1-0.2 mL).
- After each addition, allow the pH reading to stabilize and record both the volume of titrant added and the corresponding pH.
- As the pH begins to change more rapidly, decrease the increment size to accurately capture the steep rise in pH around the equivalence point.
- Continue the titration well past the equivalence point until the pH begins to plateau again.
- Data Analysis:
 - Plot pH (y-axis) versus the volume of NaOH added (x-axis) to generate a titration curve.
 - Determine the equivalence point, which is the point of maximum slope on the titration curve. This can be more accurately found by plotting the first derivative ($\Delta\text{pH}/\Delta V$ vs. V) or the second derivative ($\Delta^2\text{pH}/\Delta V^2$ vs. V).
 - The volume of titrant at the half-equivalence point is half the volume at the equivalence point.
 - The pKa is the pH value on the titration curve that corresponds to the volume at the half-equivalence point.

The following diagram outlines the experimental workflow for pKa determination.

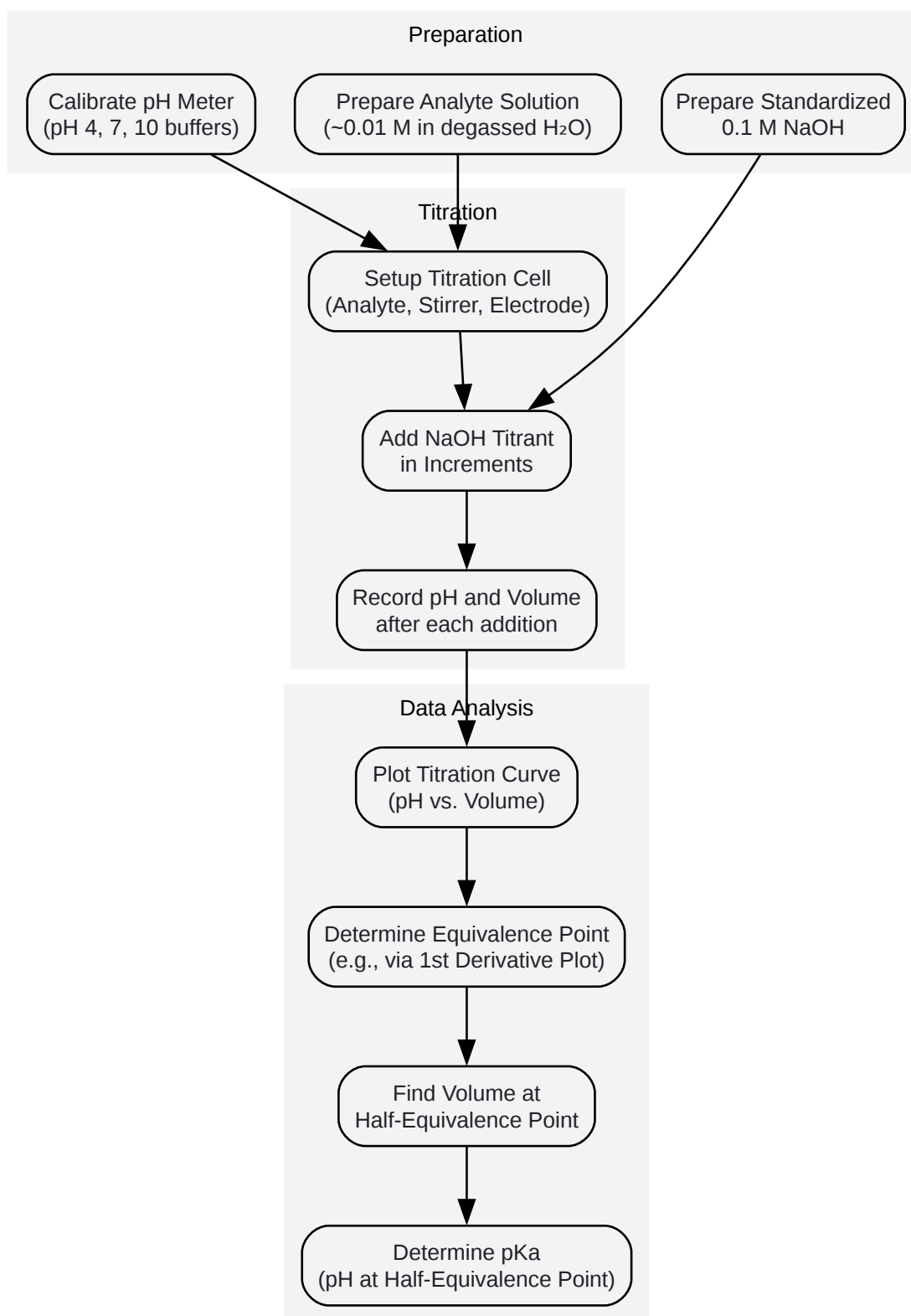

[Click to download full resolution via product page](#)

Caption: Workflow for pKa determination via potentiometric titration.

Conclusion

The acidity of **2-Cyclohexylideneacetic acid**, while not yet experimentally confirmed in the public domain, can be confidently predicted to be significantly stronger than its saturated aliphatic counterparts like cyclohexylacetic acid and cyclohexanecarboxylic acid. Its predicted pKa of 4.25 aligns it with other α,β -unsaturated and aromatic carboxylic acids such as acrylic acid and benzoic acid. This enhanced acidity is a direct consequence of the electron-withdrawing effect of the sp^2 hybridized carbons in the exocyclic double bond, which stabilizes the resulting carboxylate anion. For definitive characterization, experimental determination of its pKa via a robust method like potentiometric titration is strongly recommended. Understanding these structure-acidity relationships is crucial for predicting the behavior of novel carboxylic acid derivatives in various scientific and pharmaceutical applications.

References

- Organic Chemistry Portal. (n.d.). Acetic Acid.
- Study.com. (n.d.). Acrylic Acid Formula, Structure & Properties.
- Quora. (2018). What is the strong acid between benzoic acid and cyclohexane carboxylic acid?.
- Chemistry LibreTexts. (2023). Acidity of Carboxylic Acids.
- ResearchGate. (n.d.). Acidity trends in alpha,beta-unsaturated alkanes, silanes, germanes, and stannanes.
- Science.gov. (n.d.). potentiometric titration method: Topics by Science.gov.
- BYJU'S. (n.d.). Potentiometric Titration Principle.
- Chemistry LibreTexts. (2019). Inductive Effects in Aliphatic Carboxylic Acids.
- Chemistry LibreTexts. (2019). Acidity of Carboxylic Acids.
- BYJU'S. (n.d.). How to calculate pKa.
- Quora. (2018). Why is the unsaturated acid stronger than saturated acid?.

Need Custom Synthesis?

BenchChem offers custom synthesis for rare earth carbides and specific isotopic labeling.

Email: info@benchchem.com or [Request Quote Online](#).

Sources

- 1. byjus.com [byjus.com]

- 2. chem.libretexts.org [chem.libretexts.org]
- 3. youtube.com [youtube.com]
- 4. chem.libretexts.org [chem.libretexts.org]
- 5. Page loading... [guidechem.com]
- 6. chem.libretexts.org [chem.libretexts.org]
- 7. quora.com [quora.com]
- 8. Potentiometric titration of naphthyl esters of carboxylic acids in non-aqueous solvent - Analyst (RSC Publishing) [pubs.rsc.org]
- 9. researchgate.net [researchgate.net]
- 10. quora.com [quora.com]
- 11. potentiometric titration method: Topics by Science.gov [science.gov]
- 12. byjus.com [byjus.com]
- To cite this document: BenchChem. [A Comparative Analysis of Carboxylic Acid Acidity: The Case of 2-Cyclohexylideneacetic Acid]. BenchChem, [2026]. [Online PDF]. Available at: [https://www.benchchem.com/product/b074993#comparing-the-acidity-of-2-cyclohexylideneacetic-acid-with-other-carboxylic-acids]

Disclaimer & Data Validity:

The information provided in this document is for Research Use Only (RUO) and is strictly not intended for diagnostic or therapeutic procedures. While BenchChem strives to provide accurate protocols, we make no warranties, express or implied, regarding the fitness of this product for every specific experimental setup.

Technical Support: The protocols provided are for reference purposes. Unsure if this reagent suits your experiment? [[Contact our Ph.D. Support Team for a compatibility check](#)]

Need Industrial/Bulk Grade? [Request Custom Synthesis Quote](#)

BenchChem

Our mission is to be the trusted global source of essential and advanced chemicals, empowering scientists and researchers to drive progress in science and industry.

Contact

Address: 3281 E Guasti Rd

Ontario, CA 91761, United States

Phone: (601) 213-4426

Email: info@benchchem.com