

Technical Support Center: Dehydration of 1,2-Dimethylcyclohexanol

Author: BenchChem Technical Support Team. **Date:** May 2026

Compound of Interest

Compound Name: 1,2-Dimethylcyclohexanol

CAS No.: 1333-45-5

Cat. No.: B073200

[Get Quote](#)

Welcome to the technical support center for the acid-catalyzed dehydration of **1,2-dimethylcyclohexanol**. This guide is designed for researchers, scientists, and drug development professionals to navigate the complexities of this elimination reaction. Here, you will find troubleshooting advice and frequently asked questions to help you overcome common challenges, such as incomplete reactions and unexpected side products, ensuring a successful and efficient synthesis of the desired dimethylcyclohexene isomers.

Frequently Asked Questions (FAQs)

Q1: My dehydration of 1,2-dimethylcyclohexanol is incomplete. What are the likely causes and how can I drive the reaction to completion?

A1: Incomplete dehydration is a common issue and typically points to an equilibrium that has not been sufficiently shifted towards the products. The acid-catalyzed dehydration of an alcohol is a reversible process.^[1] To ensure complete conversion, you must employ strategies that favor the formation of the alkene products.

According to Le Chatelier's Principle, which states that a system at equilibrium will adjust to counteract any changes in conditions, removing one or more products as they are formed will shift the equilibrium to the right, favoring further product formation.[2]

Troubleshooting Strategies:

- **Distillation:** The most effective method is to distill the alkene products as they are formed. 1,2-Dimethylcyclohexene and its isomers have significantly lower boiling points than the starting alcohol, **1,2-dimethylcyclohexanol**. By setting up a fractional distillation apparatus, you can selectively remove the lower-boiling alkenes from the reaction mixture, thus driving the reaction to completion.[2]
- **Temperature Control:** Ensure the reaction temperature is high enough to facilitate the elimination reaction and the distillation of the products, but not so high as to cause excessive charring or decomposition, which can occur with strong acids like sulfuric acid.
- **Choice of Acid Catalyst:** While both sulfuric acid (H_2SO_4) and phosphoric acid (H_3PO_4) can be used, phosphoric acid is often preferred as it is less oxidizing and less prone to causing charring and the formation of sulfur dioxide.[3]

Compound	Boiling Point (°C)
1,2-Dimethylcyclohexanol	~157-159
1,2-Dimethylcyclohexene	~136
2,3-Dimethylcyclohexene	~133

Data sourced from publicly available chemical property databases.

Q2: I've obtained a mixture of alkene isomers. What are the expected products and what governs their formation?

A2: The dehydration of **1,2-dimethylcyclohexanol** proceeds through an E1 elimination mechanism, which involves the formation of a carbocation intermediate.[4] This carbocation can then lose a proton from an adjacent carbon to form a double bond. The regioselectivity of

this step is governed by Zaitsev's Rule, which states that the more substituted (and therefore more stable) alkene will be the major product.

However, the initial tertiary carbocation formed from **1,2-dimethylcyclohexanol** can also undergo rearrangements to form other, potentially more stable, carbocations. This can lead to a mixture of products.

Expected Products:

- **1,2-Dimethylcyclohexene (Zaitsev product):** This is the expected major product, formed by the removal of a proton from an adjacent carbon. It is a tetrasubstituted alkene, which is highly stable.
- **2,3-Dimethylcyclohexene (Rearrangement product):** A 1,2-hydride shift can occur where a hydrogen atom from an adjacent carbon migrates to the carbocation center, forming a new, more stable tertiary carbocation. Subsequent elimination leads to the formation of 2,3-dimethylcyclohexene.
- **1,6-Dimethylcyclohexene:** This is another possible Zaitsev product.
- **Exo-methylene isomers (e.g., 1-methyl-2-methylenecyclohexane):** These are typically minor products as they are less substituted (disubstituted) and therefore less stable than the endocyclic alkenes.

The exact product distribution can be influenced by reaction conditions such as temperature and the choice of acid catalyst.

Troubleshooting Guide

Problem: Low Yield of Desired Alkene

Possible Cause	Explanation	Recommended Solution
Equilibrium Not Shifted	The reversible nature of the reaction means that if products are not removed, an equilibrium mixture of reactants and products will be present.	As detailed in Q1, utilize fractional distillation to remove the lower-boiling alkene products as they form. This application of Le Chatelier's principle is crucial for achieving high yields.[2]
Sub-optimal Temperature	If the temperature is too low, the rate of reaction will be slow, leading to incomplete conversion in a practical timeframe.	Gradually increase the temperature of the heating mantle or sand bath while monitoring the distillation. The head temperature of the distillation column should be maintained near the boiling point of the expected alkene products.
Carbocation Rearrangements	The formation of a carbocation intermediate can lead to rearrangements, resulting in a mixture of alkene isomers and reducing the yield of a specific desired product.	While difficult to completely avoid in an E1 reaction, using a less coordinating acid like phosphoric acid and carefully controlling the temperature can sometimes influence the product ratio. For analyses, use Gas Chromatography (GC) to determine the relative amounts of each isomer in your product mixture.[1]
Loss of Product During Workup	The alkene products are volatile. Evaporation during transfer and workup steps can significantly reduce the final yield.	Keep collection flasks cooled in an ice bath and minimize the exposure of the product to the atmosphere.

Experimental Protocols

General Protocol for the Dehydration of 1,2-Dimethylcyclohexanol

This is a general procedure and may require optimization for your specific setup and scale.

Materials:

- **1,2-Dimethylcyclohexanol**
- 85% Phosphoric Acid (H_3PO_4) or Concentrated Sulfuric Acid (H_2SO_4)
- Boiling chips
- Saturated sodium bicarbonate solution
- Anhydrous sodium sulfate or magnesium sulfate
- Fractional distillation apparatus
- Separatory funnel
- Round bottom flasks
- Heating mantle or sand bath

Procedure:

- **Reaction Setup:** Assemble a fractional distillation apparatus. To a round bottom flask, add **1,2-dimethylcyclohexanol** and a few boiling chips.
- **Acid Addition:** Slowly and with stirring, add 85% phosphoric acid to the flask. The addition is exothermic, so it's advisable to cool the flask in an ice bath during this step.
- **Dehydration and Distillation:** Gently heat the mixture. As the reaction proceeds, the alkene products and water will co-distill. Collect the distillate in a receiving flask cooled in an ice

bath. Monitor the temperature at the head of the distillation column, which should be close to the boiling point of the expected alkenes.

- **Workup:** Transfer the distillate to a separatory funnel. Wash the organic layer with a saturated sodium bicarbonate solution to neutralize any remaining acid. Carefully vent the separatory funnel as carbon dioxide gas will be evolved.
- **Drying:** Separate the organic layer and dry it over anhydrous sodium sulfate or magnesium sulfate.
- **Purification:** Decant or filter the dried organic layer into a clean, dry flask. For higher purity, a final simple distillation of the alkene mixture can be performed.
- **Analysis:** Characterize the product mixture using Gas Chromatography-Mass Spectrometry (GC-MS) to identify the different isomers and determine their relative abundance.^{[5][6]} Further characterization can be done using NMR spectroscopy.

Workflow for Product Analysis

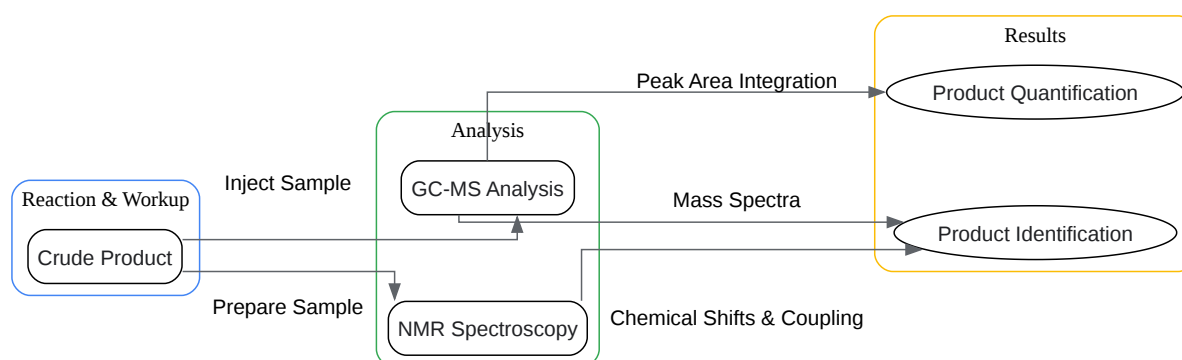

[Click to download full resolution via product page](#)

Caption: Workflow for the analysis of dehydration products.

Mechanistic Insights

The dehydration of **1,2-dimethylcyclohexanol** is a classic example of an E1 elimination reaction. Understanding the mechanism is key to troubleshooting and predicting outcomes.

E1 Mechanism of 1,2-Dimethylcyclohexanol Dehydration

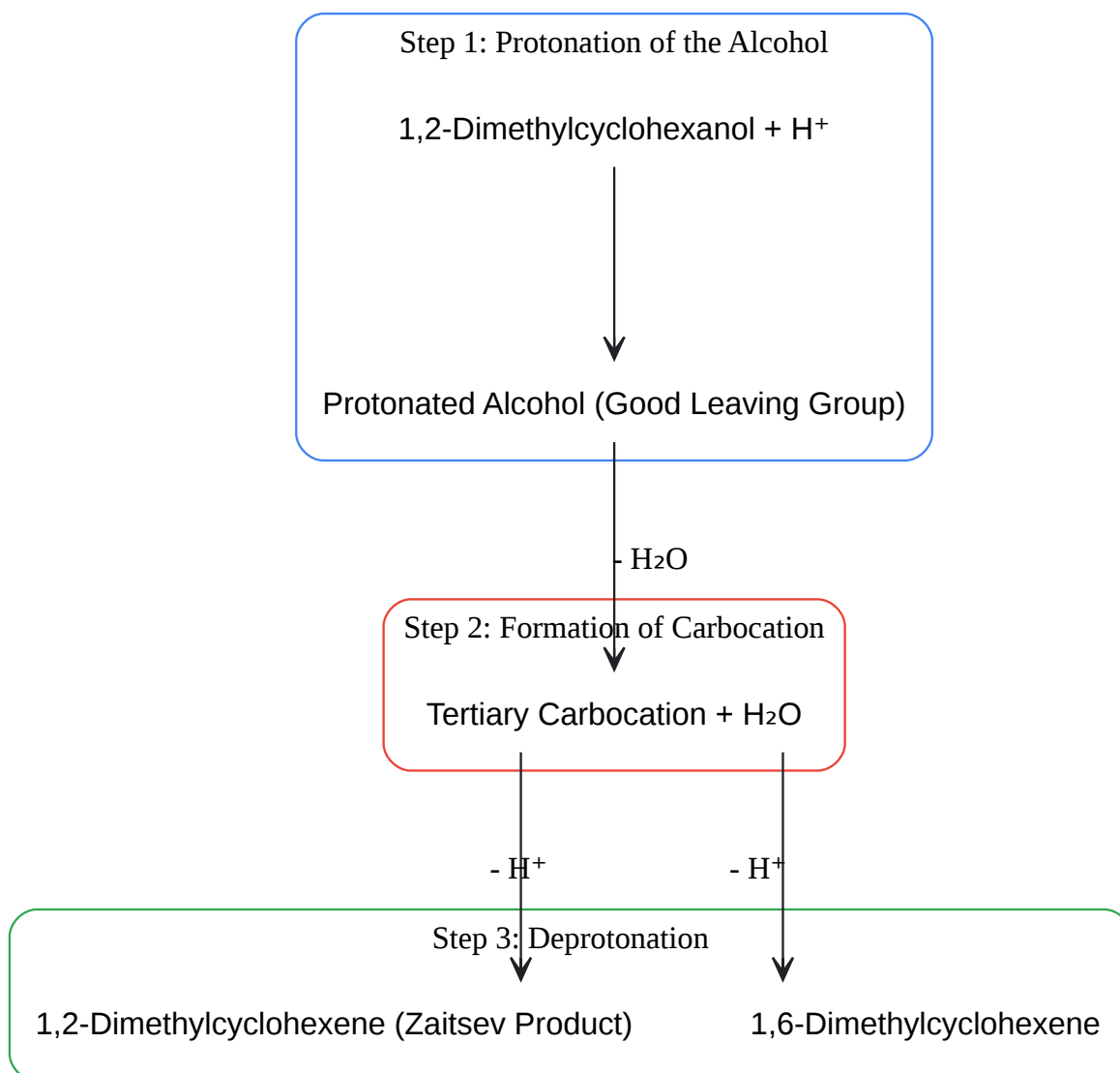

[Click to download full resolution via product page](#)

Caption: The E1 mechanism for the dehydration of **1,2-dimethylcyclohexanol**.

Carbocation Rearrangement

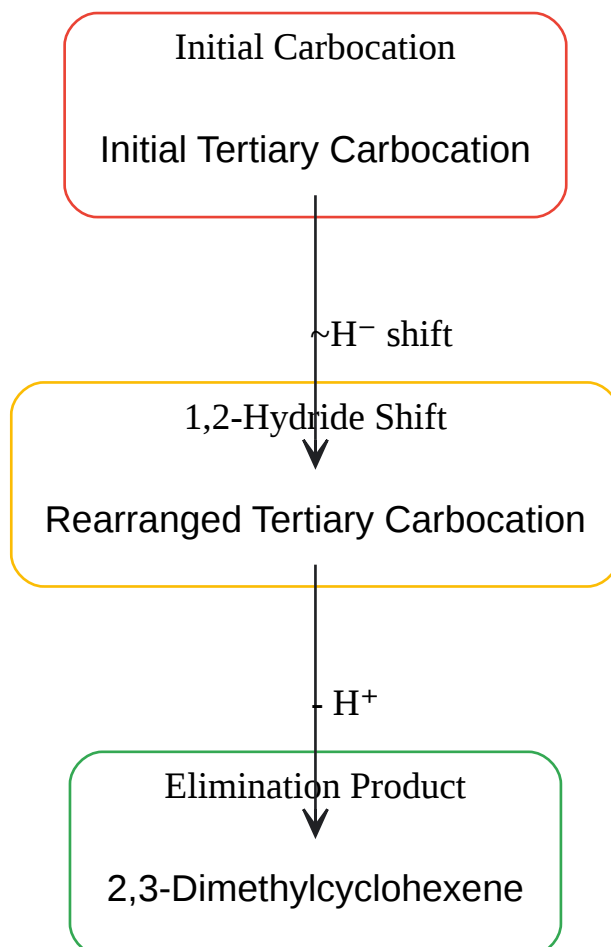

[Click to download full resolution via product page](#)

Caption: Carbocation rearrangement via a 1,2-hydride shift.

References

- Homework.Study.com. (n.d.). 1, 2-dimethylcyclohexanol readily undergoes elimination with Amberlyst 15. Show the mechanism for... Retrieved from [[Link](#)]
- CDN. (n.d.). Experiment 7 – Dehydration of Methylcyclohexanols. Retrieved from [[Link](#)]

- Azmon, B. D. (2020, March 29). Acid-Catalyzed Dehydration of 2-Methylcyclohexanol [Video]. YouTube. Retrieved from [[Link](#)]
- Science Learning Center. (n.d.). Dehydration of an alcohol. Retrieved from [[Link](#)]
- Organic Chemistry Lab Videos. (2020, April 19). Dehydration of 2-Methylcyclohexanol Experiment, Part 1: Prelab Lecture [Video]. YouTube. Retrieved from [[Link](#)]
- Organic Chemistry Lab Videos. (2020, April 20). Dehydration of 2-Methylcyclohexanol Experiment, Part 2 [Video]. YouTube. Retrieved from [[Link](#)]
- ResearchGate. (2025, August 6). Dehydration of Methylcyclohexanol Isomers in the Undergraduate Organic Laboratory and Product Analysis by Gas Chromatography-Mass Spectroscopy (GC-MS). Retrieved from [[Link](#)]
- [Chemistry] Acid catalyzed dehydration of 2,2 dimethylcyclohexanol yields a mixture of 1,2 dimethyl. (2025, January 27). [Video]. YouTube. Retrieved from [[Link](#)]
- Chemistry Steps. (n.d.). Alcohol Dehydration by E1 and E2 Elimination with Practice Problems. Retrieved from [[Link](#)]

Need Custom Synthesis?

BenchChem offers custom synthesis for rare earth carbides and specific isotopic labeling.

Email: info@benchchem.com or [Request Quote Online](#).

Sources

1. [youtube.com](https://www.youtube.com) [[youtube.com](https://www.youtube.com)]
2. [Dehydration of an alcohol](https://cs.gordon.edu) [cs.gordon.edu]
3. m.youtube.com [m.youtube.com]
4. [Alcohol Dehydration by E1 and E2 Elimination with Practice Problems - Chemistry Steps](https://chemistrysteps.com) [chemistrysteps.com]
5. [youtube.com](https://www.youtube.com) [[youtube.com](https://www.youtube.com)]
6. researchgate.net [researchgate.net]

- To cite this document: BenchChem. [Technical Support Center: Dehydration of 1,2-Dimethylcyclohexanol]. BenchChem, [2026]. [Online PDF]. Available at: [<https://www.benchchem.com/product/b073200/docs#technical-support-center-dehydration-of-1-2-dimethylcyclohexanol>]

Disclaimer & Data Validity:

The information provided in this document is for Research Use Only (RUO) and is strictly not intended for diagnostic or therapeutic procedures. While BenchChem strives to provide accurate protocols, we make no warranties, express or implied, regarding the fitness of this product for every specific experimental setup.

Technical Support: The protocols provided are for reference purposes. Unsure if this reagent suits your experiment?

Need Industrial/Bulk Grade? [Request Custom Synthesis Quote](#)

BenchChem

Our mission is to be the trusted global source of essential and advanced chemicals, empowering scientists and researchers to drive progress in science and industry.

Contact

Address: 3281 E Guasti Rd
Ontario, CA 91761, United States
Phone: (601) 213-4426
Email: info@benchchem.com

[Contact our Ph.D. Support Team for a compatibility check](#)