

Technical Support Center: 5 α -Androstan-2-one Artifact Troubleshooting

Author: BenchChem Technical Support Team. **Date:** April 2026

Compound of Interest

Compound Name: 5 α -Androstan-2-one

CAS No.: 1225-48-5

Cat. No.: B073279

[Get Quote](#)

Welcome to the Analytical Support Center for 5 α -Androstan-2-one (CAS 1225-48-5). This specialized guide provides drug development professionals and analytical chemists with field-proven, mechanistically grounded solutions for overcoming the unique experimental artifacts associated with this specific steroid isomer during Gas Chromatography-Mass Spectrometry (GC-MS) analysis.

Section 1: GC-MS Derivatization & Enolization Artifacts

Q: Why does my 5 α -Androstan-2-one standard yield two distinct chromatographic peaks when derivatized with MSTFA/TMCS?

A: This is a classic, chemically induced enolization artifact. The C-2 ketone of 5 α -Androstan-2-one is flanked by acidic α -protons at the C-1 and C-3 positions. During direct silylation at elevated temperatures, the ketone undergoes tautomerization. The silylating agent (MSTFA) rapidly traps these tautomers, yielding two distinct silyl enol ethers: the Δ 1-enol TMS ether and the Δ 2-enol TMS ether. This splits your analytical signal, ruins quantitative accuracy, and complicates spectral libraries.

Causality & Solution: To prevent this, you must protect the carbonyl group before attempting to silylate the molecule. Methoximation (MO) converts the reactive ketone into a stable methoxime derivative, locking the carbon skeleton and entirely preventing enolization [1][1].

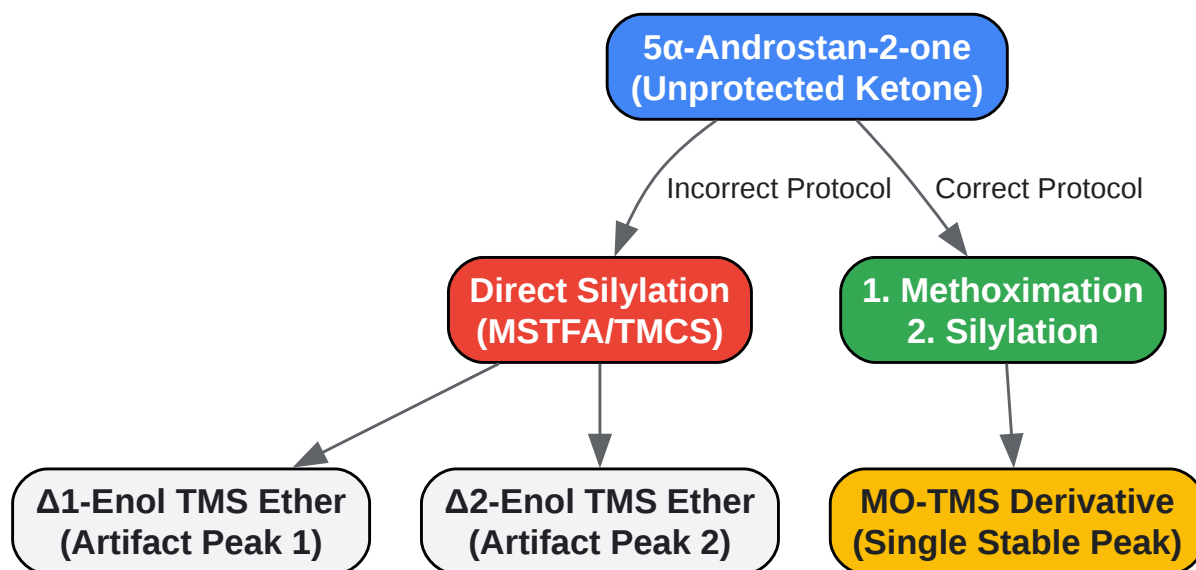

[Click to download full resolution via product page](#)

Figure 1: Derivatization workflow showing enolization artifacts vs. stable MO-TMS protection.

Step-by-Step Methodology: Self-Validating MO-TMS Derivatization

This protocol incorporates a built-in control to self-validate derivatization efficiency.

- Sample Preparation: Aliquot 50 μL of your 5 α -Androstan-2-one extract into a deactivated glass vial. Evaporate to complete dryness under a gentle stream of nitrogen.
- Methoximation (Carbonyl Protection): Add 50 μL of O-methylhydroxylamine hydrochloride (2% w/v in anhydrous pyridine). Cap tightly and incubate at 60°C for 1 hour.
- Silylation: Add 50 μL of MSTFA + 1% TMCS. Incubate at 60°C for an additional 30 minutes.

- **Self-Validation Check:** In parallel, prepare a "Negative Control" vial using only MSTFA (skip step 2). Analyze both via GC-MS. The MO-TMS vial must yield a single sharp peak. If the control vial shows the dual-peak artifact while the MO-TMS vial shows one, you have positively validated that your methoximation reagent is active and the reaction went to 100% completion.

Section 2: Electron Impact (EI) Mass Spectrometry Anomalies

Q: My EI-MS spectrum of underivatized 5 α -Androstan-2-one shows a massive unexpected peak at m/z 216 ([M-58]⁺). Is my sample thermally degrading in the GC inlet?

A: No, your sample is likely completely intact. This is a well-documented, highly specific mass spectrometric artifact unique to 2-ketosteroids. Under standard 70 eV electron impact, 5 α -Androstan-2-one (Molecular Ion m/z 274) undergoes a complex skeletal rearrangement.

Causality: Unlike 3-ketosteroids which primarily fragment via standard alpha-cleavage, the specific steric geometry of the 2-ketone facilitates a McLafferty-type rearrangement. This involves the transfer of hydrogen atoms from the C-6 and C-9 positions, followed by the cleavage of Ring A. This results in the formal neutral loss of acetone (58 Da), yielding a prominent [M-58]⁺ fragment at m/z 216 [2][2]. Misidentifying this predictable ionization mechanism as a thermal degradation product is a frequent analytical pitfall.

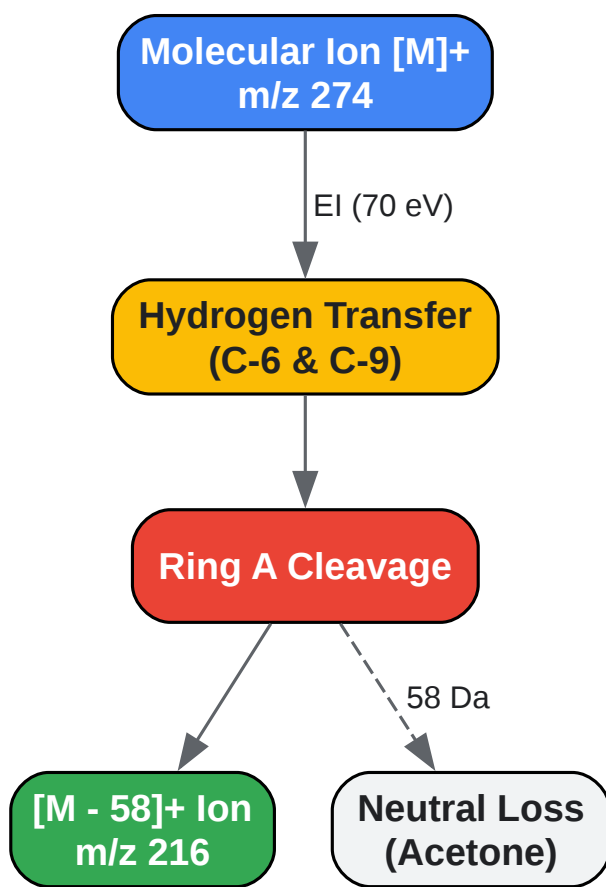

[Click to download full resolution via product page](#)

Figure 2: EI-MS fragmentation pathway of 5 α -Androstan-2-one showing formal loss of acetone.

Quantitative Data: Chromatographic & Spectral Comparison

Analytical State	Primary m/z (Base Peak)	Secondary m/z	Chromatographic Profile	Artifact Status
Underivatized (EI-MS)	216 ([M-58]⁺)	274 ([M]⁺)	Broad, tailing peak	MS Rearrangement (Acetone loss)
Direct TMS (MSTFA)	346 ([M]⁺)	331 ([M-CH₃]⁺)	Split peaks (Δ 1 & Δ 2)	Derivatization Artifact (Enolization)
MO-TMS (Corrected)	303 ([M]⁺)	272 ([M-OCH₃]⁺)	Single, sharp peak	Artifact-Free

Section 3: Thermal Degradation & Matrix Effects

Q: At low concentrations (<10 ng/mL), my 5 α -Androstan-2-one signal disappears entirely, even with MO-TMS derivatization. What is happening?

A: You are experiencing active-site adsorption in the GC inlet. Steroids are highly susceptible to interactions with active silanol (-Si-OH) groups on the glass liner or the column head [3][3]. At high concentrations, these active sites are saturated, allowing the bulk of the sample to pass. However, at trace levels, the entire sample payload can be irreversibly adsorbed or thermally degraded before reaching the column.

Step-by-Step Methodology: Inlet Deactivation & Isotope Dilution

This protocol uses isotopic tracking to self-validate whether signal loss is due to inlet physics or extraction chemistry.

- **Liner Selection:** Install a strictly deactivated, single-taper glass liner packed with deactivated quartz wool to minimize thermal shock.
- **Inlet Maintenance:** Trim 10-20 cm from the front of the analytical column (e.g., DB-5MS) to remove accumulated non-volatile matrix proteins and exposed silanols.

- Self-Validating Isotope Dilution: Spike all samples and calibration standards with a deuterated internal standard (e.g., 5 α -Androstan-2-one-d₄) prior to extraction.
 - Validation Logic: Monitor the area ratio of the unlabeled analyte to the labeled internal standard. If the absolute peak areas drop but the ratio remains constant, the issue is definitively inlet adsorption/instrumental drift. If the ratio changes erratically, the issue is isolated to your upstream extraction recovery.

References

- Halket, J. M., et al. (2005). "Chemical derivatization and mass spectral libraries in metabolic profiling by GC/MS and LC/MS/MS." *Journal of Experimental Botany*, 56(410), 219-243.
- Budzikiewicz, H., Djerassi, C., et al. (1964). "Mass Spectrometry in Structural and Stereochemical Problems. LIX. Mechanism of the Formal Loss of Acetone from 2-Oxo-5 α -androstane." *Journal of the American Chemical Society*, 86(24), 5536-5541.
- Moon, J. Y., et al. (2011). "Systematic Error in Gas Chromatography-Mass Spectrometry-Based Quantification of Hydrolyzed Urinary Steroids." *Clinical Chimica Acta*.

Need Custom Synthesis?

BenchChem offers custom synthesis for rare earth carbides and specific isotopic labeling.

Email: info@benchchem.com or [Request Quote Online](#).

Sources

- [1. academic.oup.com](https://academic.oup.com) [academic.oup.com]
- [2. pubs.acs.org](https://pubs.acs.org) [pubs.acs.org]
- [3. researchgate.net](https://researchgate.net) [researchgate.net]
- To cite this document: BenchChem. [Technical Support Center: 5 α -Androstan-2-one Artifact Troubleshooting]. BenchChem, [2026]. [Online PDF]. Available at: [<https://www.benchchem.com/product/b073279/docs#technical-support-center-5-androstan-2-one-artifact-troubleshooting>]

Disclaimer & Data Validity:

The information provided in this document is for Research Use Only (RUO) and is strictly not intended for diagnostic or therapeutic procedures. While BenchChem strives to provide accurate protocols, we make no warranties, express or implied, regarding the fitness of this product for every specific experimental setup.

Technical Support: The protocols provided are for reference purposes. Unsure if this reagent suits your experiment?

Need Industrial/Bulk Grade? [Request Custom Synthesis Quote](#)

BenchChem

Our mission is to be the trusted global source of essential and advanced chemicals, empowering scientists and researchers to drive progress in science and industry.

Contact

Address: 3281 E Guasti Rd
Ontario, CA 91761, United States
Phone: (601) 213-4426
Email: info@benchchem.com

[Contact our Ph.D. Support Team for a compatibility check](#)