

An In-depth Technical Guide to Diantimony Trioxide (CAS Number 1309-64-4)

Author: BenchChem Technical Support Team. **Date:** May 2026

Compound of Interest

Compound Name: *Diantimony trioxide*

CAS No.: *1327-33-9*

Cat. No.: *B073202*

[Get Quote](#)

For Researchers, Scientists, and Drug Development Professionals

Introduction

Diantimony trioxide, with the chemical formula Sb_2O_3 , is the most commercially significant compound of antimony.[1] It is a white, odorless, crystalline solid found in nature as the minerals valentinite and senarmontite.[1][2] This guide provides a comprehensive overview of the core properties of **diantimony trioxide**, focusing on its chemical and physical characteristics, toxicological profile, and key industrial applications.

Chemical and Physical Properties

Diantimony trioxide is an amphoteric oxide, meaning it can react with both acids and bases. [1] It is soluble in hydrochloric acid, potassium hydroxide, sodium sulfide, and tartaric acid, but insoluble in water, alcohol, and dilute sulfuric acid.

Structural Characteristics

The crystal structure of **diantimony trioxide** is temperature-dependent. Below 570°C, it exists in a cubic crystal system (α -form), and above this temperature, it transitions to an orthorhombic crystal system (β -form).[1] In the gaseous state at high temperatures (around 1560°C), it exists as dimeric Sb_4O_6 molecules with a bicyclic cage structure.[1]

Physical Data Summary

| Property | Value | Source |
|---------------------|--|--------|
| CAS Number | 1309-64-4 | [1] |
| Molecular Formula | Sb_2O_3 | [1] |
| Molar Mass | 291.518 g/mol | [1] |
| Appearance | White, odorless solid | [1] |
| Density | 5.2 g/cm ³ (α -form), 5.67 g/cm ³ (β -form) | [1] |
| Melting Point | 656 °C (1,213 °F; 929 K) | [1] |
| Boiling Point | 1,425 °C (2,597 °F; 1,698 K) (sublimes) | [1] |
| Solubility in Water | 370±37 µg/L (at 20.8-22.9 °C) | [1] |

Key Applications

The primary application of **diantimony trioxide** is as a flame retardant synergist, particularly in combination with halogenated materials.[1][3][4] It is also utilized in various other industrial processes.

Flame Retardant Synergist

While not a flame retardant on its own, **diantimony trioxide** significantly enhances the effectiveness of halogenated flame retardants.[5][6][7][8] This synergistic effect is crucial in polymers, helping to form less flammable chars.[1][3] This property makes it a vital component in the manufacturing of fire-resistant plastics, textiles, rubber, and coatings.[4][9][10]

2.1.1. Mechanism of Action as a Flame Retardant

The flame retardant mechanism involves a synergistic reaction with halogenated compounds. When exposed to heat, the halogenated material releases hydrogen halides (HX, where X is a halogen). **Diantimony trioxide** then reacts with these halides to form antimony trihalides (SbX_3).^[6] These volatile antimony compounds act in the gas phase to scavenge highly reactive radicals ($\text{H}\cdot$ and $\text{OH}\cdot$) that propagate the combustion process.^{[6][11]} This action effectively quenches the flame.^[11] Additionally, in the solid phase, it promotes the formation of a protective char layer, which insulates the underlying material from heat and oxygen.^{[3][11]}

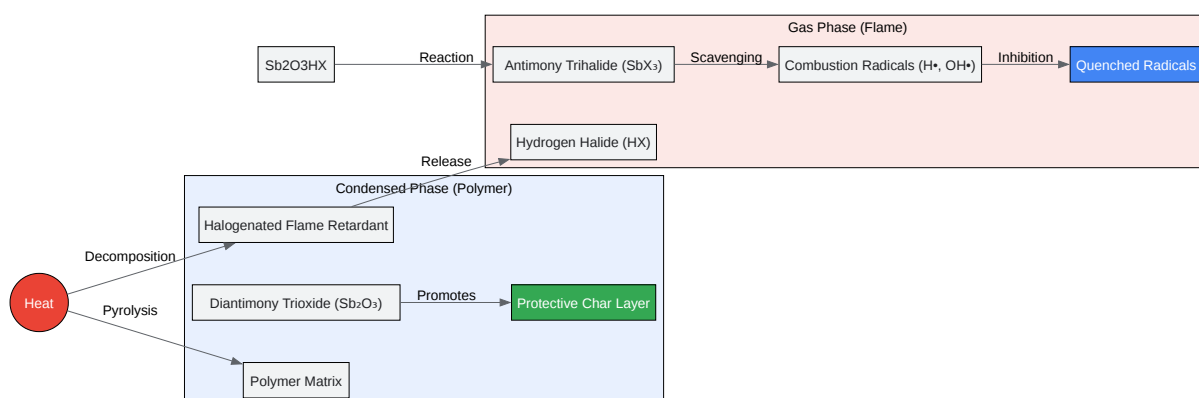

[Click to download full resolution via product page](#)

Caption: Synergistic flame retardant mechanism of **diantimony trioxide**.

Other Industrial Uses

- Catalyst: It serves as a catalyst in the production of polyethylene terephthalate (PET) plastics and in the vulcanization of rubber.[1][9]
- Glass and Ceramics: **Diantimony trioxide** is used as an opacifying agent for glasses, ceramics, and enamels.[1][4][10] It also acts as a fining agent to remove bubbles in molten glass, thereby improving clarity and optical quality.[10]
- Pigments: Some specialty pigments contain antimony.[1]
- Alloys: It is used to increase the hardness and strength of lead alloys.[9]

Toxicological Profile

The primary routes of human exposure to **diantimony trioxide** are inhalation, ingestion, and dermal contact.[12]

Acute Effects

Acute poisoning from **diantimony trioxide** is rare.[13]

- Inhalation: Dusts and fumes can irritate the respiratory tract and mucous membranes, potentially causing laryngitis, pharyngitis, tracheitis, and bronchitis.[13]
- Dermal Contact: It can cause skin irritation, and repeated exposure may lead to "antimony spots," which are papules and pustules around sweat and sebaceous glands.[12][13]
- Eye Contact: It is an eye irritant and can cause conjunctivitis.[13]
- Ingestion: Ingestion can lead to gastrointestinal issues such as nausea, vomiting, abdominal pain, and diarrhea.[13]

Chronic Effects

Long-term exposure to **diantimony trioxide** can have more severe health consequences.

- Respiratory System: Chronic inhalation can lead to pneumoconiosis, chronic bronchitis, and emphysema.[12][14][15]

- **Carcinogenicity:** The International Agency for Research on Cancer (IARC) has classified **diantimony trioxide** as Group 2B, possibly carcinogenic to humans, based on sufficient evidence in animals.[\[9\]](#)[\[16\]](#) Lung tumors have been observed in rats exposed to antimony trioxide via inhalation.[\[12\]](#)[\[16\]](#)[\[17\]](#) The State of California has also listed it as a carcinogen under Proposition 65.[\[12\]](#)[\[18\]](#)
- **Reproductive and Developmental Effects:** Some studies suggest a potential for reproductive and developmental toxicity, including an increased incidence of spontaneous abortions in occupationally exposed women, though the evidence is not conclusive.[\[9\]](#)[\[12\]](#)[\[14\]](#)

Toxicity Data Summary

| Endpoint | Value | Species | Route | Source |
|---------------------------|------------------|---------|-------|----------------------|
| LD ₅₀ | >7000 mg/kg | Rat | Oral | [1] |
| Oral Reference Dose (RfD) | 0.0004 mg/kg/day | - | - | [12] |

Safety and Handling

Given the potential health hazards, strict safety precautions should be followed when handling **diantimony trioxide**.

Personal Protective Equipment (PPE)

- **Respiratory Protection:** In case of insufficient ventilation or dust formation, a suitable respirator should be worn.[\[19\]](#)[\[20\]](#)
- **Hand Protection:** Chemical-resistant gloves are recommended.[\[19\]](#)
- **Eye Protection:** Safety glasses with side-shields or goggles should be used.[\[20\]](#)[\[21\]](#)
- **Skin and Body Protection:** Long-sleeved protective clothing should be worn to minimize skin contact.[\[19\]](#)[\[20\]](#)

Handling and Storage Procedures

- Ventilation: Work should be conducted in a well-ventilated area to minimize dust inhalation. [\[19\]](#)
- Hygiene: Do not eat, drink, or smoke in areas where **diantimony trioxide** is handled. [\[19\]](#)[\[21\]](#)
Hands should be washed thoroughly after handling. [\[19\]](#)
- Storage: Store in a dry, cool, and well-ventilated place in tightly closed containers. [\[20\]](#)
- Spills: In case of a spill, avoid generating dust. Use a vacuum or sweep up the material and place it in a suitable container for disposal. [\[19\]](#)

Environmental Effects

Diantimony trioxide is considered a threat to the environment, and measures should be taken to limit its release. [\[2\]](#) In the European Union, it is classified as a "heavy metal" in the context of hazardous waste. [\[18\]](#) In the United States, it is listed as a hazardous substance under the Comprehensive Environmental Response, Compensation, and Liability Act (CERCLA). [\[22\]](#)

Conclusion

Diantimony trioxide (CAS 1309-64-4) is a versatile inorganic compound with significant industrial applications, most notably as a flame retardant synergist. Its unique chemical and physical properties make it highly effective in this role. However, it is also associated with potential health and environmental risks, including respiratory irritation, skin issues, and possible carcinogenicity. Therefore, a thorough understanding of its properties and adherence to strict safety protocols are essential for its responsible use in research, development, and industrial settings.

References

- Antimony trioxide - Wikipedia. [\[Link\]](#)
- Antimony Trioxide - CAREX Canada. [\[Link\]](#)
- How does antimony trioxide work as flame retardant?. [\[Link\]](#)
- What are the applications of antimony trioxide?. [\[Link\]](#)

- Antimony trioxide (UK PID). Inchem.org. [[Link](#)]
- Antimony Trioxide. Amspec. [[Link](#)]
- Understanding the Synergistic Mechanism of Antimony Trioxide in Flame Retardancy. NINGBO INNO PHARMCHEM CO.,LTD. [[Link](#)]
- **DIANTIMONY TRIOXIDE**. Ataman Kimya. [[Link](#)]
- How do flame retardants work? Cefic-efra.org. [[Link](#)]
- Antimony Compounds As Federal Hazardous Air Pollutant. California Air Resources Board. [[Link](#)]
- Antimony Trioxide - Toxicological Risks of Selected Flame-Retardant Chemicals. NCBI. [[Link](#)]
- Provisional Peer Reviewed Toxicity Values for Antimony Trioxide. U.S. Environmental Protection Agency. [[Link](#)]
- ANTIMONY TRIOXIDE HAZARD SUMMARY. New Jersey Department of Health. [[Link](#)]
- Health And Environmental Effects Profile for Antimony Oxides. U.S. Environmental Protection Agency. [[Link](#)]
- ANTIMONY TRIOXIDE AR. Loba Chemie. [[Link](#)]
- Antimony Trioxide. Aardvark Clay. [[Link](#)]
- antimony trioxide. Sdfine. [[Link](#)]
- The exposure to and health effects of antimony. PubMed Central. [[Link](#)]
- Antimony ToxFAQs. Agency for Toxic Substances and Disease Registry - CDC. [[Link](#)]
- Safety Data Sheet: Antimony(III) oxide. Carl ROTH. [[Link](#)]
- Waste and Environmental Restrictions. International Antimony Association. [[Link](#)]

Need Custom Synthesis?

BenchChem offers custom synthesis for rare earth carbides and specific isotopic labeling.

Email: info@benchchem.com or [Request Quote Online](#).

Sources

- [1. Antimony trioxide - Wikipedia \[en.wikipedia.org\]](#)
- [2. Diantimony trioxide | 1309-64-4 \[chemicalbook.com\]](#)
- [3. flame-retardant.alfa-chemistry.com \[flame-retardant.alfa-chemistry.com\]](#)
- [4. What are the applications of antimony trioxide? - Liaoning Victory Fire-retardant Material Technology Co., Ltd. \[vtalc.com\]](#)
- [5. nihonseiko.co.jp \[nihonseiko.co.jp\]](#)
- [6. How does antimony trioxide work as flame retardant? - Liaoning Victory Fire-retardant Material Technology Co., Ltd. \[vtalc.com\]](#)
- [7. Antimony Trioxide – Amspec \[amspec.net\]](#)
- [8. aerofiltri.it \[aerofiltri.it\]](#)
- [9. carexcanada.ca \[carexcanada.ca\]](#)
- [10. Scimplify Blogs | Industrial Applications of Antimony Trioxide and Key Sb Properties | Scimplify \[scimplify.com\]](#)
- [11. nbinno.com \[nbinno.com\]](#)
- [12. ww2.arb.ca.gov \[ww2.arb.ca.gov\]](#)
- [13. Antimony trioxide \(UK PID\) \[inchem.org\]](#)
- [14. Antimony Trioxide - Toxicological Risks of Selected Flame-Retardant Chemicals - NCBI Bookshelf \[ncbi.nlm.nih.gov\]](#)
- [15. The exposure to and health effects of antimony - PMC \[pmc.ncbi.nlm.nih.gov\]](#)
- [16. hhpptv.ornl.gov \[hhpptv.ornl.gov\]](#)
- [17. atsdr.cdc.gov \[atsdr.cdc.gov\]](#)
- [18. antimony.com \[antimony.com\]](#)
- [19. aardvarkclay.com \[aardvarkclay.com\]](#)

- [20. thermofishersci.in \[thermofishersci.in\]](https://thermofishersci.in)
- [21. nj.gov \[nj.gov\]](https://nj.gov)
- [22. Health And Environmental Effects Profile for Antimony Oxides | Risk Assessment Portal | US EPA \[assessments.epa.gov\]](#)
- To cite this document: BenchChem. [An In-depth Technical Guide to Diantimony Trioxide (CAS Number 1309-64-4)]. BenchChem, [2026]. [Online PDF]. Available at: [\[https://www.benchchem.com/product/b073202/docs#an-in-depth-technical-guide-to-diantimony-trioxide-cas-number-1309-64-4\]](https://www.benchchem.com/product/b073202/docs#an-in-depth-technical-guide-to-diantimony-trioxide-cas-number-1309-64-4)

Disclaimer & Data Validity:

The information provided in this document is for Research Use Only (RUO) and is strictly not intended for diagnostic or therapeutic procedures. While BenchChem strives to provide accurate protocols, we make no warranties, express or implied, regarding the fitness of this product for every specific experimental setup.

Technical Support: The protocols provided are for reference purposes. Unsure if this reagent suits your experiment?

Need Industrial/Bulk Grade? [Request Custom Synthesis Quote](#)

BenchChem

Our mission is to be the trusted global source of essential and advanced chemicals, empowering scientists and researchers to drive progress in science and industry.

Contact

Address: 3281 E Guasti Rd
Ontario, CA 91761, United States
Phone: (601) 213-4426
Email: info@benchchem.com

[Contact our Ph.D. Support Team for a compatibility check](#)

