

Technical Support: Acylation of 2,5-Dimethylpyrrole

Author: BenchChem Technical Support Team. **Date:** May 2026

Compound of Interest

Compound Name: 1-(3,5-Dimethyl-1H-Pyrrol-2-yl)Ethan-1-One

CAS No.: 1500-93-2

Cat. No.: B072406

[Get Quote](#)

Topic: Troubleshooting Side Reactions & Process Optimization Audience: Organic Chemists, Process Engineers, Drug Discovery Scientists

Introduction: The Reactivity Paradox

2,5-Dimethylpyrrole (2,5-DMP) presents a unique synthetic paradox. While the methyl groups at the

-positions (2 and 5) block the most reactive sites, they also inductively donate electron density into the ring, making the

-positions (3 and 4) exceptionally nucleophilic.

This heightened reactivity makes 2,5-DMP an excellent substrate for acylation but simultaneously renders it hypersensitive to acid-catalyzed polymerization and oxidative degradation. Successful acylation requires a precise balance between activating the electrophile (acylating agent) and preventing the destruction of the nucleophile (pyrrole).

Module 1: The "Red Tar" Phenomenon (Oligomerization)

The Issue: The reaction mixture turns dark red or black, and workup yields an insoluble resin instead of the desired ketone.

Root Cause: Acid-Catalyzed Polymerization. Pyrroles are acid-sensitive.^[1] In the presence of strong protic acids (HCl byproduct) or unbuffered Lewis acids, the pyrrole ring is protonated.

This protonated species (

) acts as a potent electrophile, reacting with unprotonated pyrrole to form dimers, trimers, and eventually "pyrrole red" polymers.

Troubleshooting Protocol

Variable	Recommendation	Mechanism/Rationale
Lewis Acid	Use or	is often too harsh, generating high local concentrations of (if moisture is present) or complexing too strongly. allows for milder acylation.
Reagent	Acetic Anhydride > Acyl Chloride	Acyl chlorides generate HCl gas as a byproduct. Anhydrides generate carboxylic acids, which are less damaging to the pyrrole ring.
Addition	Reverse Addition	Add the pyrrole slowly to the Lewis Acid/Acylation agent mixture. This ensures the pyrrole is instantly consumed by the acylation agent rather than pooling and reacting with itself.
Temp	0°C to -10°C	Low temperature suppresses the activation energy required for polymerization while still allowing the facile Friedel-Crafts reaction to proceed.

Visualizing the Failure Mode

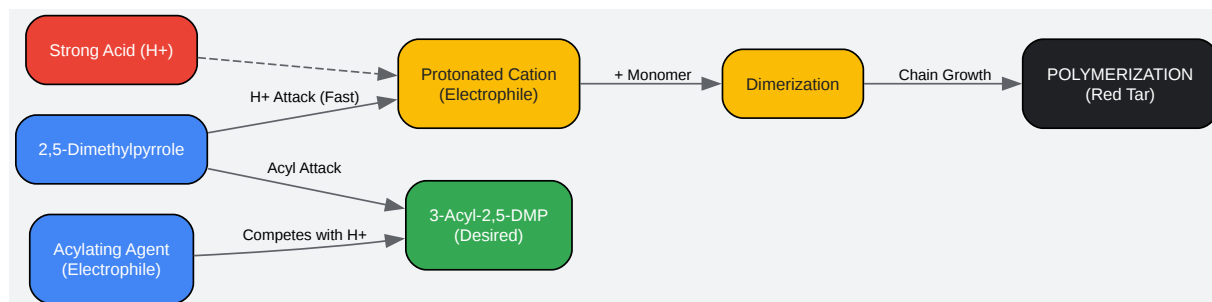

[Click to download full resolution via product page](#)

Figure 1: The competition between productive acylation and destructive polymerization. Protonation of the ring triggers the "Red Tar" cascade.

Module 2: Regioselectivity & Polyacylation

The Issue: Formation of 3,4-diacyl-2,5-dimethylpyrrole alongside the desired mono-acyl product.

Root Cause: The pyrrole ring is so electron-rich that the deactivating effect of the first acyl group is sometimes insufficient to prevent a second attack, especially if local concentrations of the acylating agent are high.

Diagnostic Table:

Observation	Diagnosis	Corrective Action
Two spots on TLC (0.4 and 0.6)	Mixture of Mono- and Di-acyl products.	Reduce acylating agent equivalents to 0.95 eq.
Low Yield + Recovery of SM	Under-reaction due to fear of di-acylation.	Increase reaction time, not reagent excess.
Product crystallizes poorly	Contamination with di-acyl impurity.	Recrystallize from Ethanol/Water or purify via column chromatography (Di-acyl is usually more polar).

Selectivity Tip: Due to the symmetry of 2,5-dimethylpyrrole, the C3 and C4 positions are equivalent. You will strictly get one mono-acylated isomer. This simplifies NMR analysis (look for the loss of symmetry in the methyl peaks).

Module 3: N-Acylation vs. C-Acylation

The Issue: The acyl group attaches to the Nitrogen (N1) instead of the Carbon (C3).

Root Cause: Kinetic vs. Thermodynamic Control.

- N-Acylation is kinetically favored (hard nucleophile/hard electrophile interaction), especially in the presence of strong bases (NaH) or ionic solvents.[2]
- C-Acylation is thermodynamically favored and is the standard outcome of Friedel-Crafts conditions (Lewis Acid catalysis).

Mechanism Check: If you observe N-acylated product (identifiable by a downfield shift of ring protons and lack of N-H stretch in IR), your Lewis acid may be deactivated, or you are using basic conditions.

Correction: Ensure anhydrous conditions. Water deactivates Lewis acids (like

), preventing the formation of the "hard" acylium ion required for C-acylation.

Master Protocol: Optimized C-Acylation of 2,5-DMP

Objective: Synthesis of 3-acetyl-2,5-dimethylpyrrole. Scale: 10 mmol basis.

- Preparation: Flame-dry a 50 mL round-bottom flask under .
- Reagent Mix: Charge with 10 mL anhydrous and 1.1 eq (11 mmol) Acetic Anhydride.
- Catalyst Activation: Cool to 0°C. Add 1.1 eq (11 mmol) dropwise. Stir for 15 mins.
 - Why? This pre-forms the active electrophilic complex.
- Substrate Addition: Dissolve 10 mmol 2,5-Dimethylpyrrole in 5 mL . Add this solution dropwise to the reaction mixture over 30 minutes.
 - Critical: This "Reverse Addition" keeps the concentration of free pyrrole low relative to the electrophile, suppressing polymerization.
- Reaction: Stir at 0°C for 1 hour, then warm to RT for 2 hours.
- Quench: Pour mixture into ice-cold saturated (vigorous stirring).
 - Note: Neutralization is vital to prevent acid-hydrolysis or polymerization during workup.
- Isolation: Extract with DCM, wash with brine, dry over , and concentrate. Recrystallize from aqueous ethanol.

Frequently Asked Questions (FAQ)

Q1: Can I use

instead of

?

- A: Yes, but it is riskier.

is a stronger Lewis acid and releases HCl gas if acetyl chloride is used. If you must use , ensure strictly anhydrous conditions and use a buffer (like nitromethane solvent) to moderate activity.

Q2: My product has a strong "vinegar" smell even after drying.

- A: This is trapped acetic acid (if anhydride was used). Pyrroles can "hold" solvents. Wash the organic layer thoroughly with until basic, or sublime the product under high vacuum for final purification.

Q3: Why did my reaction turn black immediately upon adding the catalyst?

- A: You likely added the catalyst to the pyrrole without solvent or cooling. The exotherm caused immediate oxidative polymerization. Always dilute the pyrrole and add it to the cold catalyst mixture (Reverse Addition).

Q4: Is the 3-isomer really the only product? What about the 2-isomer?

- A: In 2,5-dimethylpyrrole, the 2 and 5 positions are blocked by methyl groups. Direct substitution at the methyl group does not occur under Friedel-Crafts conditions. Therefore, the 3-isomer (which is identical to the 4-isomer due to symmetry) is the exclusive mono-acylated product.

References

- Preparation of 2,5-Dimethylpyrrole (Precursor Context)
 - Young, D. M., & Allen, C. F. H. (1936). 2,5-Dimethylpyrrole.[3] Organic Syntheses, 16, 25.
 - [3]
- Friedel-Crafts Acylation Mechanisms & Regioselectivity

- Anderson, H. J., & Lee, S. F. (1965). Pyrrole chemistry. IV. The acylation of pyrrole and some substituted pyrroles.[1][4] Canadian Journal of Chemistry, 43(2), 409-414.
- Polymerization Mechanism (The "Red Tar")
 - Salmon, M., et al. (1982). Chemical modification of polypyrrole.
- Vilsmeier-Haack Formylation (Alternative Acylation Route)
 - Silverstein, R. M., Ryskiewicz, E. E., & Willard, C. (1956). 2-Pyrrolealdehyde, 3-Pyrrolealdehyde, and 2,5-Dimethyl-3-pyrrolealdehyde. Organic Syntheses, 36, 74.

Need Custom Synthesis?

BenchChem offers custom synthesis for rare earth carbides and specific isotopic labeling.

Email: info@benchchem.com or [Request Quote Online](#).

Sources

- 1. mbbcollege.in [mbbcollege.in]
- 2. pdf.benchchem.com [pdf.benchchem.com]
- 3. Organic Syntheses Procedure [orgsyn.org]
- 4. par.nsf.gov [par.nsf.gov]
- To cite this document: BenchChem. [Technical Support: Acylation of 2,5-Dimethylpyrrole]. BenchChem, [2026]. [Online PDF]. Available at: [<https://www.benchchem.com/product/b072406/docs#technical-support-acylation-of-2-5-dimethylpyrrole>]

Disclaimer & Data Validity:

The information provided in this document is for Research Use Only (RUO) and is strictly not intended for diagnostic or therapeutic procedures. While BenchChem strives to provide accurate protocols, we make no warranties, express or implied, regarding the fitness of this product for every specific experimental setup.

Technical Support: The protocols provided are for reference purposes. Unsure if this reagent suits your experiment?

Need Industrial/Bulk Grade? [Request Custom Synthesis Quote](#)

BenchChem

Our mission is to be the trusted global source of essential and advanced chemicals, empowering scientists and researchers to drive progress in science and industry.

Contact

Address: 3281 E Guasti Rd
Ontario, CA 91761, United States
Phone: (601) 213-4426
Email: info@benchchem.com

[Contact our Ph.D. Support Team for a compatibility check](#)