

13C NMR spectral data for 4'-nitrochalcone carbon assignment

Author: BenchChem Technical Support Team. **Date:** May 2026

Compound of Interest

Compound Name: *(2E)-1-(4-nitrophenyl)-3-phenylprop-2-en-1-one*

CAS No.: 1152-48-3

Cat. No.: B072045

[Get Quote](#)

Comparative C NMR Assignment Guide: 4'-Nitrochalcone

Executive Summary & Application Context

In medicinal chemistry, chalcones (1,3-diaryl-2-propen-1-ones) are privileged scaffolds due to their anti-inflammatory, anticancer, and antibacterial properties. The precise structural elucidation of nitro-substituted chalcones is critical for Structure-Activity Relationship (SAR) studies, as the position of the nitro group (electron-withdrawing) significantly alters the electronic landscape of the

-unsaturated ketone system.

This guide provides a definitive

C NMR assignment for 4'-nitrochalcone (nitro group on the acetophenone-derived Ring A), comparing it against the unsubstituted chalcone and the regioisomer 4-nitrochalcone (nitro group on the benzaldehyde-derived Ring B).

Experimental Protocol: Synthesis & Characterization

To ensure the data presented is reproducible, we define the standard workflow used to generate the spectral data.

2.1. Synthesis (Claisen-Schmidt Condensation)[1]

- Reagents: 4-Nitroacetophenone (1.0 eq), Benzaldehyde (1.0 eq), NaOH (catalytic), Ethanol (solvent).
- Procedure:
 - Dissolve 4-nitroacetophenone in ethanol at 0–5°C.
 - Add benzaldehyde followed by dropwise addition of aqueous NaOH (10%).
 - Stir at room temperature for 4–6 hours.
 - Precipitate the product by pouring into ice-cold water/HCl.
 - Purification: Recrystallization from ethanol or column chromatography (Hexane:EtOAc 8:2).

2.2. NMR Acquisition Parameters

- Instrument: 400 MHz or 500 MHz spectrometer (e.g., Bruker Avance).
- Frequency:
C observation at 100/125 MHz.
- Solvent: CDCl₃
(Deuterated Chloroform) with TMS internal standard (0.00).
- Temperature: 298 K.
- Pulse Sequence: Proton-decoupled

C (zgpg30).

- Scans: Minimum 1024 scans to resolve quaternary carbons.

Comparative Data Analysis

The following table contrasts the

C chemical shifts of 4'-nitrochalcone with its analogs. This comparison isolates the electronic effect of the nitro group based on its position.

Table 1: Comparative

C NMR Chemical Shifts (

, ppm) in CDCl

Carbon Position	4'-Nitrochalcone (Target)	Unsubstituted Chalcone (Reference)	4-Nitrochalcone (Regioisomer)	Assignment Logic
C=O (Carbonyl)	189.1	190.6	189.7	Conjugation with 4'-NO slightly shields C=O relative to parent.
C- (C3)	146.5	144.8	141.5	C- is deshielded by resonance; 4-NO (Ring B) reduces this deshielding.
C- (C2)	121.3	122.0	125.5	C- is shielded; 4-NO (Ring B) deshields it via induction.
C-1' (Ipsos to C=O)	142.8	138.1	137.8	4'-NO exerts strong inductive/resonance effect on Ring A ipso.
C-4' (Ipsos to NO)	150.1	132.8 (C4')	128.5 (C4')	4'-NO Diagnostic peak for C-NO attachment (strongly deshielded).[2]
C-1 (Ring B Ipsos)	134.2	134.8	140.8	Attachment to alkene; shifts

vary by Ring B
substitution.

Key Structural Numbering:

- Ring A (Prime): Attached to Carbonyl (

to

).

- Ring B: Attached to Alkene

-position (

to

).

- Linker:

.

3.1. Detailed Spectral Interpretation

- The Nitro Effect (Ring A): In 4'-nitrochalcone, the nitro group is on the carbonyl side. The C4' carbon (directly attached to NO

) appears significantly downfield at ~150 ppm due to the strong electron-withdrawing nature of the nitro group (inductive and resonance deshielding). Conversely, the C1' carbon (ipso to carbonyl) shifts downfield to ~142.8 ppm compared to the unsubstituted analog (~138 ppm).

- The Enone System (

): The carbonyl carbon (C=O) resonates at 189.1 ppm. The olefinic carbons show characteristic trans-enone behavior: C-

is significantly deshielded (146.5 ppm) due to resonance contribution from the carbonyl oxygen (making C-

electropositive), while C-

remains shielded (121.3 ppm).

- Distinguishing Regioisomers: Comparing 4'-nitro vs. 4-nitro is crucial. If the nitro group moves to Ring B (4-nitrochalcone), the C-

signal shifts downfield to 125.5 ppm (vs 121.3 ppm in 4'-nitro), and the C-

signal moves upfield to 141.5 ppm. This "crossover" of alkene shifts is a primary diagnostic tool.

Assignment Logic & Workflow

To guarantee scientific integrity, assignments should not rely solely on literature values but must be self-validated using 2D NMR. The following diagram illustrates the logical workflow for assigning these signals.

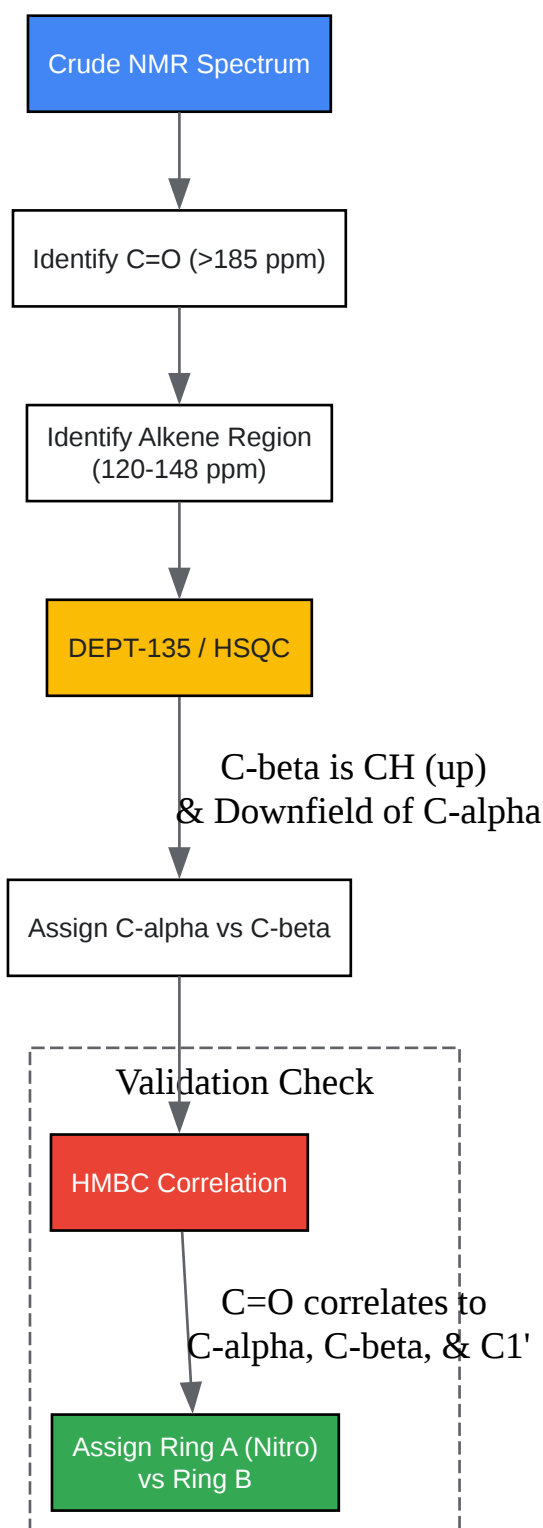

[Click to download full resolution via product page](#)

Caption: Logical workflow for the unambiguous assignment of chalcone carbon signals using 1D and 2D NMR techniques.

Mechanistic Insight: Why the Shifts Matter

Understanding these shifts is not merely an academic exercise; it predicts reactivity in drug development:

- **Michael Acceptor Reactivity:** The chemical shift of C- correlates with electrophilicity. In 4'-nitrochalcone, the high shift (146.5 ppm) suggests the C- position is highly susceptible to nucleophilic attack (e.g., by cysteine residues in proteins), which is the primary mechanism of action for chalcone-based covalent inhibitors.
- **Metabolic Stability:** The C4' position (150.1 ppm) is electronically deactivated by the nitro group, making Ring A resistant to oxidative metabolism (CYP450 oxidation) compared to electron-rich rings.

References

- BenchChem. (2025). Application Notes and Protocols for Distinguishing Chalcone Isomers using NMR Spectroscopy. Retrieved from
- Royal Society of Chemistry. (2024). Transborylation Enabled, Borane-Catalysed Reductive Cyanation of Enones. Chemical Science. Retrieved from
- National Institutes of Health (NIH). (2025). (E)-1-(4-Nitrophenyl)-3-phenylprop-2-en-1-one Compound Summary. PubChem.[3][4] Retrieved from
- MDPI. (2024). A Complete 1H and 13C NMR Data Assignment for Substituted Chalcones. Molecules. Retrieved from
- ChemicalBook. (2024). (E)-1-(4-Methoxyphenyl)-3-(4-nitrophenyl)-2-propene-1-one NMR Spectrum. Retrieved from

Need Custom Synthesis?

BenchChem offers custom synthesis for rare earth carbides and specific isotopic labeling.

Email: info@benchchem.com or [Request Quote Online](#).

Sources

- [1. researchgate.net \[researchgate.net\]](https://www.researchgate.net)
- [2. pdfs.semanticscholar.org \[pdfs.semanticscholar.org\]](https://pdfs.semanticscholar.org)
- [3. \(2E\)-1-\(4-Nitrophenyl\)-3-phenyl-2-propen-1-one | C15H11NO3 | CID 5291959 - PubChem \[pubchem.ncbi.nlm.nih.gov\]](#)
- [4. \(2E\)-1-\(4-Nitrophenyl\)-3-phenyl-2-propen-1-one | C15H11NO3 | CID 5291959 - PubChem \[pubchem.ncbi.nlm.nih.gov\]](#)
- To cite this document: BenchChem. [13C NMR spectral data for 4'-nitrochalcone carbon assignment]. BenchChem, [2026]. [Online PDF]. Available at: [\[https://www.benchchem.com/product/b072045/docs#13c-nmr-spectral-data-for-4-nitrochalcone-carbon-assignment\]](https://www.benchchem.com/product/b072045/docs#13c-nmr-spectral-data-for-4-nitrochalcone-carbon-assignment)

Disclaimer & Data Validity:

The information provided in this document is for Research Use Only (RUO) and is strictly not intended for diagnostic or therapeutic procedures. While BenchChem strives to provide accurate protocols, we make no warranties, express or implied, regarding the fitness of this product for every specific experimental setup.

Technical Support: The protocols provided are for reference purposes. Unsure if this reagent suits your experiment?

Need Industrial/Bulk Grade? [Request Custom Synthesis Quote](#)

BenchChem

Our mission is to be the trusted global source of essential and advanced chemicals, empowering scientists and researchers to drive progress in science and industry.

Contact

Address: 3281 E Guasti Rd
Ontario, CA 91761, United States
Phone: (601) 213-4426
Email: info@benchchem.com

Contact our Ph.D. Support Team for a compatibility check