

functionalization of the pyridine ring in 6-Chloro-4-methoxypicolinonitrile

Author: BenchChem Technical Support Team. **Date:** May 2026

Compound of Interest

Compound Name: 6-Chloro-4-methoxypicolinonitrile

CAS No.: 193074-46-3

Cat. No.: B071603

[Get Quote](#)

Application Note: Functionalization of 6-Chloro-4-methoxypicolinonitrile

Compound: **6-Chloro-4-methoxypicolinonitrile** (CAS: 193074-46-3) Molecular Weight: 168.58 g/mol Core Reactivity: Pyridine Electrophile / Nitrile Dipole[1][2]

Strategic Overview: The "Push-Pull" Reactivity Map

The **6-Chloro-4-methoxypicolinonitrile** scaffold presents a unique "push-pull" electronic system.[1] The pyridine ring is electron-deficient (π -deficient), activated by the ring nitrogen and the strong electron-withdrawing nitrile group (EWG) at C2.[1] However, this electrophilicity is modulated by the electron-donating methoxy group (EDG) at C4.

- The "Pull" (Activation): The C2-nitrile and pyridine nitrogen create a strong dipole, significantly lowering the LUMO energy at the C6 position, making it susceptible to nucleophilic attack (S_NAr) and oxidative addition (Pd-catalysis).

- The "Push" (Modulation): The C4-methoxy group donates electron density via resonance (+M effect), rendering the C6 position less electrophilic than in 4,6-dichloropicolinonitrile. This necessitates specific ligand choices for cross-coupling and optimized temperatures for SNAr. [1]

Reactivity Topology Diagram[1]

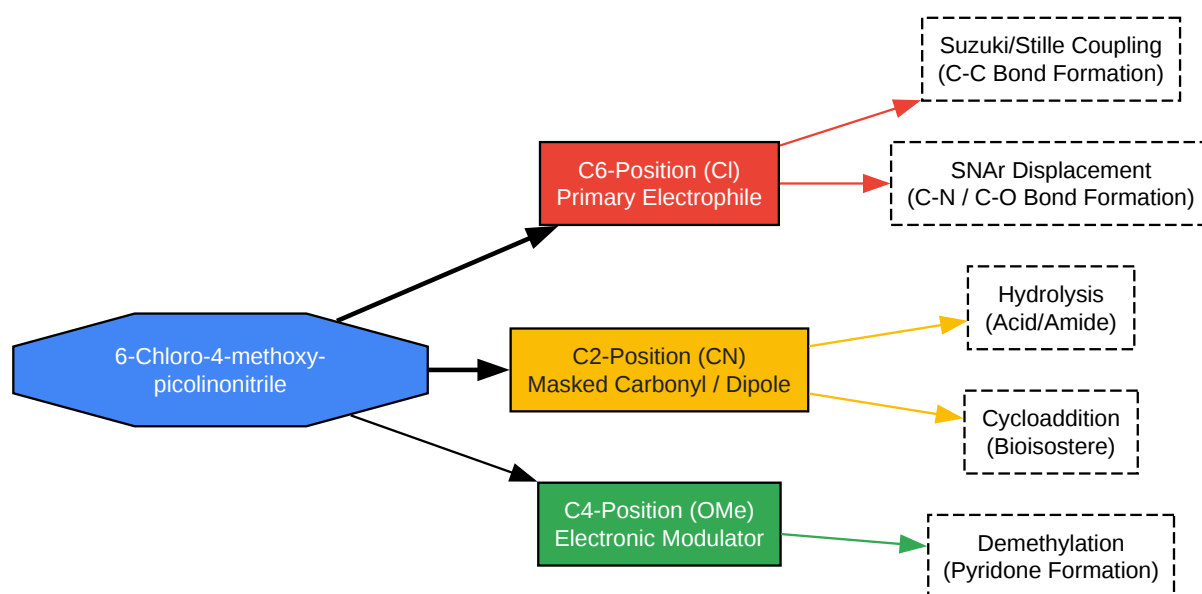

[Click to download full resolution via product page](#)

Figure 1: Reactivity topology showing the primary electrophilic site (C6) and the functionalizable nitrile handle (C2).

Module 1: C6-Functionalization (The Electrophilic Handle)

The C6-chlorine is the primary handle for diversification.[1] Due to the C4-OMe deactivation, standard conditions for chloropyridines may result in sluggish conversion.[1]

Protocol A: Suzuki-Miyaura Cross-Coupling

Objective: Installation of aryl/heteroaryl groups at C6.[1] Challenge: Oxidative addition is the rate-limiting step due to the electron-rich C4-OMe.[1] Solution: Use of electron-rich, bulky

phosphine ligands (e.g., XPhos, SPhos) or bidentate ligands (dppf) to facilitate oxidative addition.

Step-by-Step Protocol:

- Preparation: In a glovebox or under Argon, charge a reaction vial with:
 - **6-Chloro-4-methoxypicolinonitrile** (1.0 equiv)[1]
 - Aryl Boronic Acid (1.2 – 1.5 equiv)
 - Catalyst: Pd(OAc)₂ (5 mol%) + XPhos (10 mol%) OR Pd(dppf)Cl₂ (5 mol%)
 - Base: K₃PO₄ (3.0 equiv, finely ground)
- Solvent System: Add degassed 1,4-Dioxane/Water (4:1 ratio).[1] Concentration: 0.1 M.[1]
- Reaction: Seal and heat to 90°C for 4–12 hours.
 - Note: Monitor by LCMS.[1] If the starting material persists, increase temperature to 110°C.
- Workup: Cool to RT. Filter through a Celite pad (eluting with EtOAc).[1] Wash filtrate with brine, dry over Na₂SO₄, and concentrate.
- Purification: Flash chromatography (Hexanes/EtOAc).

Protocol B: Regioselective S_NAr Displacement

Objective: Introduction of amines or alkoxides at C6.[1] Mechanism: Addition-Elimination (Meisenheimer complex intermediate).[1] Critical Insight: The reaction requires heat.[1] Unlike 2,4-dichloropyridines where C4 reacts at RT, the C6-Cl in this scaffold requires thermal activation (60–80°C).[1]

Step-by-Step Protocol (Amination):

- Reactants: Dissolve **6-Chloro-4-methoxypicolinonitrile** (1.0 equiv) in anhydrous DMSO or NMP (0.2 M).
- Nucleophile: Add Primary/Secondary Amine (1.2 – 2.0 equiv).

- Base: Add DIPEA (2.0 – 3.0 equiv). If using a volatile amine, use a sealed tube.
- Execution: Heat to 80°C for 6 hours.
 - Validation: Check for the disappearance of the characteristic aryl chloride isotope pattern in MS.
- Workup: Dilute with water (10x volume). The product often precipitates.[1] If not, extract with EtOAc.

Module 2: C2-Nitrile Transformations[1]

The nitrile group at C2 is a "masked" carbonyl and a gateway to heterocycles. It is generally stable to C6-coupling conditions, allowing for late-stage modification.[1]

Protocol C: Controlled Hydrolysis to Picolinamide

Objective: Convert nitrile to primary amide without hydrolyzing the C4-OMe or C6-Cl (if still present).[1] Reagent: Katritzky's peroxide method or basic hydrolysis.[1]

Protocol:

- Dissolve substrate in DMSO (0.5 M).[1]
- Add K_2CO_3 (0.5 equiv) and 30% H_2O_2 (3.0 equiv) dropwise at 0°C.
- Allow to warm to RT and stir for 30 minutes.
- Quench: Add saturated Na_2SO_3 (carefully, exothermic).
- Isolation: The amide usually precipitates upon water addition.[1]

Protocol D: [3+2] Cycloaddition to Tetrazole

Objective: Synthesis of a bioisostere for carboxylic acid. Reagent: Sodium Azide (NaN_3) + Zinc Bromide ($ZnBr_2$) or Triethylamine Hydrochloride.[1]

Protocol:

- Dissolve nitrile substrate in DMF or Toluene.[1]
- Add NaN₃ (1.5 equiv) and ZnBr₂ (1.0 equiv).[1]
- Heat to 100–110°C for 12–24 hours.
 - Safety: Azide reactions require blast shields.[1] Do not use chlorinated solvents (formation of diazidomethane).[1]
- Workup: Acidify carefully with 1N HCl to pH 3–4 to protonate the tetrazole (precipitate formation).

Sequence Logic & Troubleshooting

When designing a synthesis, the Order of Operations is critical to avoid side reactions.

Recommended Sequence:

- Step 1: C6 Functionalization. Perform Suzuki or SNAr first.[1] The C2-nitrile is robust and survives these conditions.[1]
- Step 2: C2 Transformation. Hydrolysis or reduction should be performed second.[1]
 - Why? A C2-amide or C2-amine can coordinate to Pd catalysts, poisoning the C6-coupling reaction.[1] A C2-acid is incompatible with basic coupling conditions.[1]

Troubleshooting Table

Problem	Probable Cause	Solution
Low Yield in Suzuki	Protodehalogenation (Cl replaced by H)	Switch solvent to Toluene/Water; reduce reaction time; ensure absolute exclusion of O ₂ .
No Reaction in SNAr	C4-OMe deactivation	Increase Temp to 100°C; Switch solvent to NMP; Use a stronger base (e.g., NaH) for alcohol nucleophiles.
C4-OMe Cleavage	Harsh acidic conditions (e.g., HBr, BBr ₃)	Avoid strong Lewis acids. C4-OMe is acid-labile, yielding the pyridone. ^[1]

Workflow Diagram

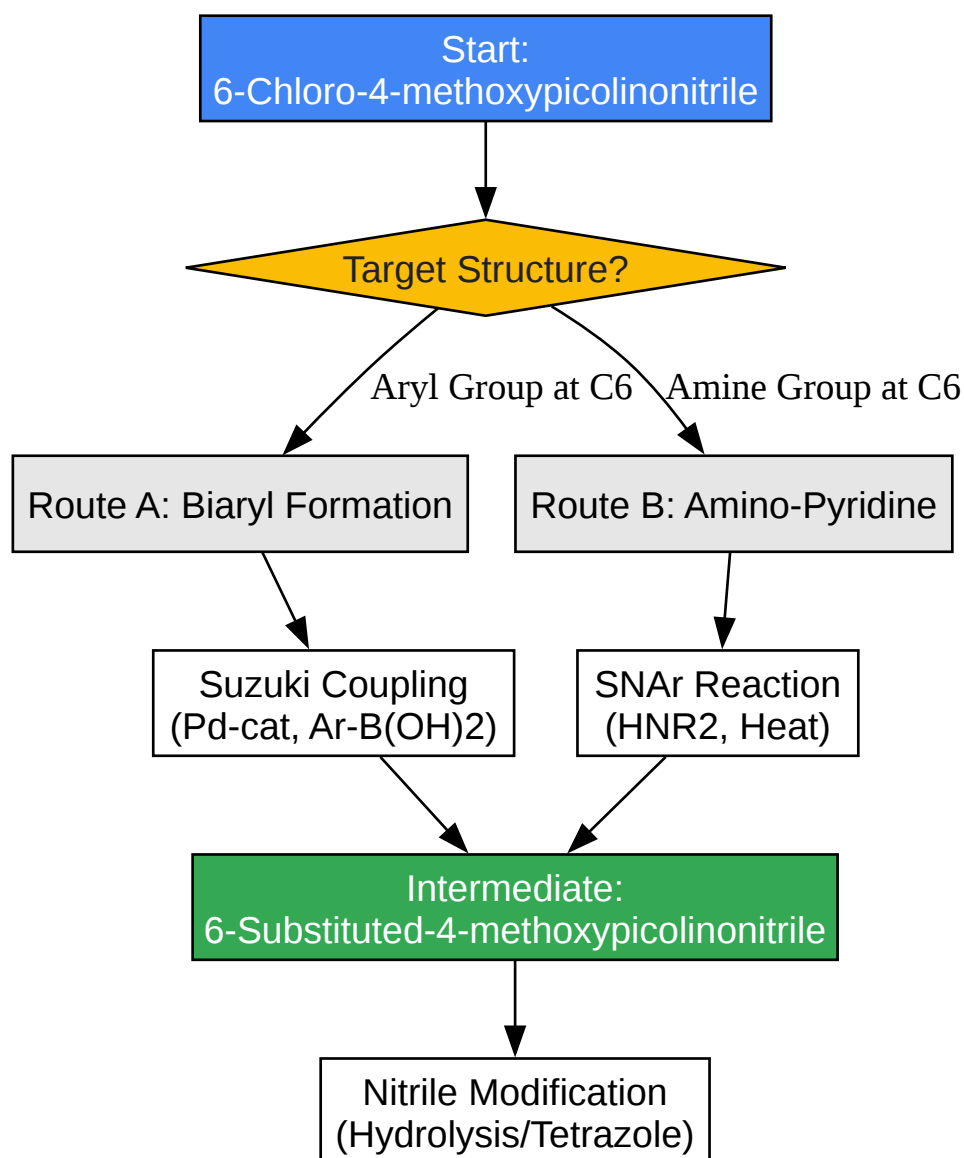

[Click to download full resolution via product page](#)

Figure 2: Recommended synthetic workflow prioritizing C6 functionalization.

References

- National Center for Biotechnology Information. (n.d.).^[1] PubChem Compound Summary for CID 193074-46-3, **6-Chloro-4-methoxypicolinonitrile**. Retrieved January 31, 2026, from [\[Link\]](#)
- Li, J. J. (2014).^[1] Name Reactions in Heterocyclic Chemistry II. Wiley.^[1] (General reference for Pyridine SNAr and Coupling mechanisms).

- Schlosser, M., & Rausis, T. (2004). The regioselective functionalization of chloropyridines. *European Journal of Organic Chemistry*. (Foundational work on halopyridine reactivity).
- Pharmaceutical Substances. (2024).[1][3][4] Syntheses of Kinase Inhibitors containing 2-cyanopyridine scaffolds. (General application context).

Need Custom Synthesis?

BenchChem offers custom synthesis for rare earth carbides and specific isotopic labeling.

Email: info@benchchem.com or [Request Quote Online](#).

Sources

- [1. Methyl 6-chloro-4-methoxypicolinate | C8H8ClNO3 | CID 45489866 - PubChem \[pubchem.ncbi.nlm.nih.gov\]](#)
- [2. mdpi.com \[mdpi.com\]](#)
- [3. researchgate.net \[researchgate.net\]](#)
- [4. nbinno.com \[nbinno.com\]](#)
- To cite this document: BenchChem. [functionalization of the pyridine ring in 6-Chloro-4-methoxypicolinonitrile]. BenchChem, [2026]. [Online PDF]. Available at: [\[https://www.benchchem.com/product/b071603/docs#functionalization-of-the-pyridine-ring-in-6-chloro-4-methoxypicolinonitrile\]](https://www.benchchem.com/product/b071603/docs#functionalization-of-the-pyridine-ring-in-6-chloro-4-methoxypicolinonitrile)

Disclaimer & Data Validity:

The information provided in this document is for Research Use Only (RUO) and is strictly not intended for diagnostic or therapeutic procedures. While BenchChem strives to provide accurate protocols, we make no warranties, express or implied, regarding the fitness of this product for every specific experimental setup.

Technical Support: The protocols provided are for reference purposes. Unsure if this reagent suits your experiment?

Need Industrial/Bulk Grade? [Request Custom Synthesis Quote](#)

BenchChem

Our mission is to be the trusted global source of essential and advanced chemicals, empowering scientists and researchers to drive progress in science and industry.

Contact

Address: 3281 E Guasti Rd

Ontario, CA 91761, United States

Phone: (601) 213-4426

Email: info@benchchem.com

[Contact our Ph.D. Support Team for a compatibility check](#)