

Biological Activity of Pyrrolidine-Benzamide Conjugates

Author: BenchChem Technical Support Team. **Date:** May 2026

Compound of Interest

Compound Name: 4-(Pyrrolidin-1-yl)benzamide

CAS No.: 183557-79-1

Cat. No.: B071296

[Get Quote](#)

Executive Summary: The Convergence of Two Privileged Scaffolds

The conjugation of pyrrolidine (a saturated 5-membered nitrogen heterocycle) and benzamide (a benzene ring bearing an amide moiety) represents a strategic scaffold fusion in medicinal chemistry. Both moieties are considered "privileged structures"—molecular frameworks capable of providing ligands for diverse receptors.

This guide analyzes the biological activity of these conjugates across three distinct therapeutic axes:

- Metabolic Regulation: Inhibition of 11 β -Hydroxysteroid Dehydrogenase Type 1 (11 β -HSD1) for type 2 diabetes.^[1]
- Neuropsychiatry: Stereoselective antagonism of Dopamine D2 receptors.
- Epigenetics: Histone Deacetylase (HDAC) inhibition, where benzamide acts as the Zinc Binding Group (ZBG).

Module A: Metabolic Regulation (11 β -HSD1 Inhibition)

Mechanistic Rationale

11 β -HSD1 is an intracellular enzyme that catalyzes the conversion of inert cortisone to active cortisol.^[1] Elevated cortisol levels in adipose tissue and the liver contribute to insulin resistance and metabolic syndrome. Pyrrolidine-benzamide conjugates have emerged as potent, selective inhibitors of this enzyme, distinct from earlier adamantyl-based generations.

Structure-Activity Relationship (SAR)

The core pharmacophore typically involves a pyrrolidine carboxamide linked to a lipophilic moiety.

- The Pyrrolidine Ring: Often substituted at the 3-position. It restricts conformational flexibility, improving entropy of binding.
- The Benzamide Moiety: Acts as the "Eastern" aryl group, often interacting with the catalytic site or the cofactor (NADPH) binding pocket.

Key Findings (Cheng et al., 2010):

- PF-877423, a pyrrolidine carboxamide derivative, demonstrated low nanomolar potency against human 11 β -HSD1.
- Selectivity: High selectivity (>100-fold) over 11 β -HSD2 is critical to avoid mineralocorticoid receptor-mediated hypertension.

Quantitative Data: Potency Profile

Table 1: Comparative Inhibitory Activity of Pyrrolidine Carboxamide Analogs (Representative Data)

Compound ID	R-Group (Pyrrolidine N)	Benzamide Substitution	h11 β -HSD1 IC50 (nM)	Selectivity (vs HSD2)
Analog A	Cyclopropyl	4-fluoro	12	> 500x
Analog B	Isopropyl	2,4-dichloro	45	> 200x
PF-877423	(Optimized)	(Optimized)	< 10	> 1000x

Module B: Neuropharmacology (Dopamine D2 Antagonism)[2]

The Stereochemical Switch

Benzamide derivatives (e.g., Sulpiride) are classic antipsychotics. Conjugating these with pyrrolidine creates a scaffold where biological activity is strictly controlled by stereochemistry.

- Mechanism: Blockade of postsynaptic D2 receptors in the mesolimbic system.
- Chirality: The (S)-enantiomer of N-[(1-ethyl-2-pyrrolidinyl)methyl]benzamide (Sulpiride) is the active antipsychotic form. However, in specific benzyl-pyrrolidine analogs, the (R)-enantiomer has shown superior affinity (J. Med. Chem, 1987).

Molecular Interaction

The basic nitrogen of the pyrrolidine ring mimics the amine of dopamine, forming a crucial salt bridge with Asp114 (in D2 transmembrane domain 3). The benzamide moiety engages in aromatic pi-stacking and hydrogen bonding with serine residues in transmembrane domain 5.

Module C: Epigenetics (HDAC Inhibition)

Benzamide as a Zinc Binding Group (ZBG)

Unlike hydroxamic acids (e.g., SAHA), which are pan-HDAC inhibitors, 2-aminobenzamides (e.g., Entinostat) are selective for Class I HDACs (HDAC 1, 2, 3).

The Conjugate Design

- ZBG: 2-aminobenzamide coordinates the Zinc ion at the bottom of the catalytic pocket.

- Linker: An aryl or alkyl chain spanning the hydrophobic tunnel.
- Cap Group: The pyrrolidine moiety sits at the rim of the pocket, interacting with surface residues. This "Cap" determines isoform selectivity and solubility.

Experimental Protocols (Self-Validating Systems)

Protocol A: Synthesis of Pyrrolidine-Benzamide

Conjugate

Rationale: This protocol uses HATU for efficient amide coupling, minimizing racemization of the chiral pyrrolidine.

Reagents:

- Substituted Benzoic Acid (1.0 eq)
- Chiral 3-aminopyrrolidine derivative (1.1 eq)
- HATU (1.2 eq)
- DIPEA (3.0 eq)
- Solvent: DMF (anhydrous)

Step-by-Step Workflow:

- Activation: Dissolve Benzoic Acid in DMF under N₂ atmosphere. Add DIPEA and stir for 5 min. Add HATU and stir for 15 min at 0°C to form the active ester.
- Coupling: Add the pyrrolidine amine dropwise. Allow warming to Room Temperature (RT) and stir for 4–12 hours.
- Validation (TLC/LCMS): Monitor disappearance of acid starting material. A new peak with M+1 corresponding to the conjugate must appear.
- Workup: Dilute with EtOAc, wash with NaHCO₃ (sat) to remove unreacted acid, then Brine. Dry over MgSO₄.

- Purification: Flash column chromatography (MeOH/DCM gradient).

Protocol B: 11 β -HSD1 Scintillation Proximity Assay (SPA)

Rationale: A homogeneous assay measuring the reduction of labeled cortisone.

- Enzyme Prep: Microsomes expressing human 11 β -HSD1.
- Substrate: [3H]-Cortisone and NADPH (cofactor).
- Incubation: Mix enzyme, test compound (pyrrolidine-benzamide), and substrate in assay buffer (pH 7.4). Incubate at 37°C for 60 min.
- Termination: Add SPA beads coated with anti-cortisol antibody.
- Readout: Only [3H]-Cortisol bound to beads emits light. [3H]-Cortisone does not bind.
- Data Analysis: Plot % Inhibition vs. Log[Compound]. Calculate IC50 using non-linear regression.

Visualization of Biological Mechanisms

Diagram: SAR Logic of Pyrrolidine-Benzamide Conjugates

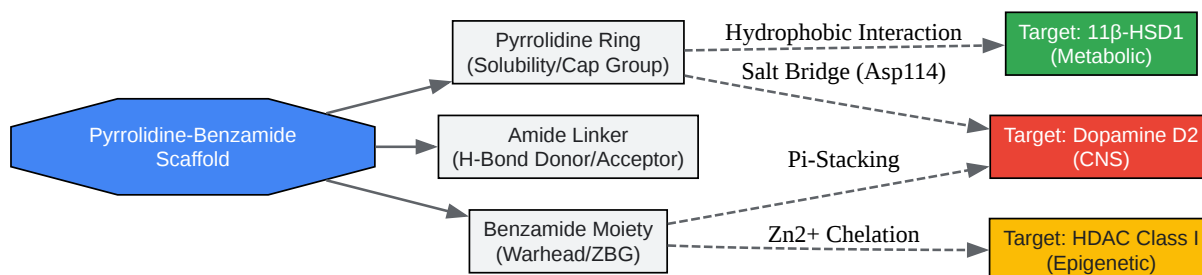

[Click to download full resolution via product page](#)

Caption: Functional decomposition of the scaffold showing how specific structural domains map to distinct biological targets (HSD1, D2, HDAC).

Diagram: 11 β -HSD1 Inhibition Workflow

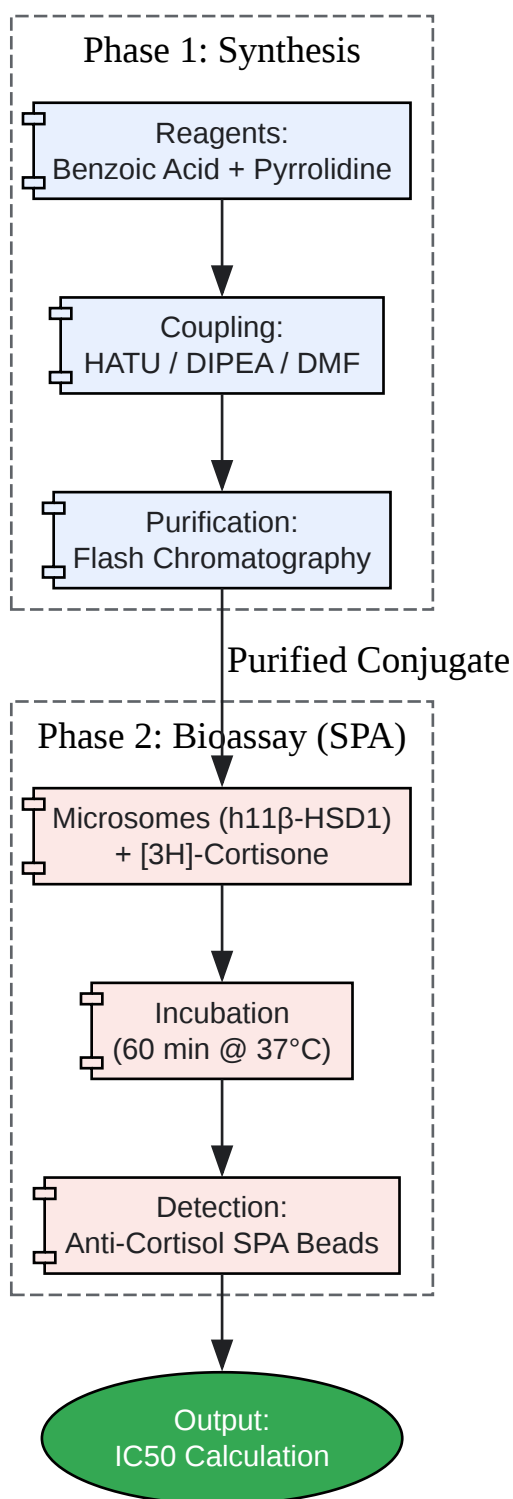

[Click to download full resolution via product page](#)

Caption: Step-by-step experimental pipeline from chemical synthesis to biological validation via Scintillation Proximity Assay.

References

- Cheng, H., et al. (2010).[2] "The development and SAR of pyrrolidine carboxamide 11beta-HSD1 inhibitors." *Bioorganic & Medicinal Chemistry Letters*.
- Pinzi, L., et al. (2023).[3] "Discovery of potent pyrrolo-pyrimidine and purine HDAC inhibitors for the treatment of advanced prostate cancer." *European Journal of Medicinal Chemistry*.
- Högberg, T., et al. (1987). "Potential antipsychotic agents. 9. Synthesis and stereoselective dopamine D-2 receptor blockade of a potent class of substituted (R)-N-[(1-benzyl-2-pyrrolidiny)methyl]benzamides." [4] *Journal of Medicinal Chemistry*.
- Bhat, A. A., et al. (2022).[5] "Pyrrolidine derivatives as antibacterial agents, current status and future prospects: a patent review." *Pharmaceutical Patent Analyst*.
- Boyle, C. D., et al. (2008). "Discovery of Novel, Potent Benzamide Inhibitors of 11beta-hydroxysteroid Dehydrogenase Type 1 (11beta-HSD1)." *Bioorganic & Medicinal Chemistry Letters*.

Need Custom Synthesis?

BenchChem offers custom synthesis for rare earth carbides and specific isotopic labeling.

Email: info@benchchem.com or [Request Quote Online](#).

Sources

- [1. mdpi.com \[mdpi.com\]](https://www.mdpi.com)
- [2. The development and SAR of pyrrolidine carboxamide 11beta-HSD1 inhibitors - PubMed \[pubmed.ncbi.nlm.nih.gov\]](https://pubmed.ncbi.nlm.nih.gov/)
- [3. Discovery of potent pyrrolo-pyrimidine and purine HDAC inhibitors for the treatment of advanced prostate cancer - PubMed \[pubmed.ncbi.nlm.nih.gov\]](https://pubmed.ncbi.nlm.nih.gov/)

- [4. Potential antipsychotic agents. 9. Synthesis and stereoselective dopamine D-2 receptor blockade of a potent class of substituted \(R\)-N-\[\(1-benzyl-2-pyrrolidiny\)methyl\]benzamides. Relations to other side chain congeners - PubMed \[pubmed.ncbi.nlm.nih.gov\]](#)
- [5. Synthesis, Characterization and Biological Evaluation of Novel Benzamidine Derivatives: Newer Antibiotics for Periodontitis Treatment - PMC \[pmc.ncbi.nlm.nih.gov\]](#)
- To cite this document: BenchChem. [Biological Activity of Pyrrolidine-Benzamide Conjugates]. BenchChem, [2026]. [Online PDF]. Available at: [\[https://www.benchchem.com/product/b071296/docs#biological-activity-of-pyrrolidine-benzamide-conjugates\]](https://www.benchchem.com/product/b071296/docs#biological-activity-of-pyrrolidine-benzamide-conjugates)

Disclaimer & Data Validity:

The information provided in this document is for Research Use Only (RUO) and is strictly not intended for diagnostic or therapeutic procedures. While BenchChem strives to provide accurate protocols, we make no warranties, express or implied, regarding the fitness of this product for every specific experimental setup.

Technical Support: The protocols provided are for reference purposes. Unsure if this reagent suits your experiment?

Need Industrial/Bulk Grade? [Request Custom Synthesis Quote](#)

BenchChem

Our mission is to be the trusted global source of essential and advanced chemicals, empowering scientists and researchers to drive progress in science and industry.

Contact

Address: 3281 E Guasti Rd
Ontario, CA 91761, United States
Phone: (601) 213-4426
Email: info@benchchem.com

[Contact our Ph.D. Support Team for a compatibility check](#)

