

Advanced Extraction & Purification Protocols for 3-Acetyltetramic Acid[1]

Author: BenchChem Technical Support Team. **Date:** May 2026

Compound of Interest

Compound Name: 4-Acetyl-3-hydroxy-1H-pyrrol-2(5H)-one
CAS No.: 170436-02-9
Cat. No.: B069421

[Get Quote](#)

Executive Summary

Target Analyte: 3-Acetyltetramic acid (and 3-acyl derivatives: Tenuazonic acid, Equisetin, Magnesidin). Primary Matrices: Fungal/Bacterial Fermentation Broth, Plant Tissue. Core Challenge: The tetramic acid moiety exhibits complex keto-enol tautomerism and strong metal chelation (particularly Cu^{2+} , Mg^{2+} , Fe^{3+}), rendering standard neutral extraction inefficient.

This guide details a pH-modulated, chelation-disrupting extraction strategy. Unlike generic alkaloid or lipid extractions, isolating 3-acetyltetramic acid (3-ATA) requires strict control of the protonation state to disrupt stable metal complexes and ensure partitioning into organic phases.

Strategic Considerations: The Chemistry of Extraction

To design a valid protocol, one must understand the underlying equilibrium. 3-ATA exists in four rapid interconverting tautomeric forms. In biological matrices, it predominantly exists as a

stable metal chelate (often Magnesium or Copper) or an enolate anion at neutral pH.

The "Acid-Break" Principle:

- Neutral pH (7.0): 3-ATA is often ionized or chelated. Solubility in organic solvents (EtOAc, CHCl_3) is poor.
- Acidic pH (< 3.0): Protonation of the C-3 enol group breaks the metal-ligand bond and suppresses ionization. The neutral molecule becomes highly lipophilic.

Diagram 1: Chemical Equilibrium & Extraction Logic

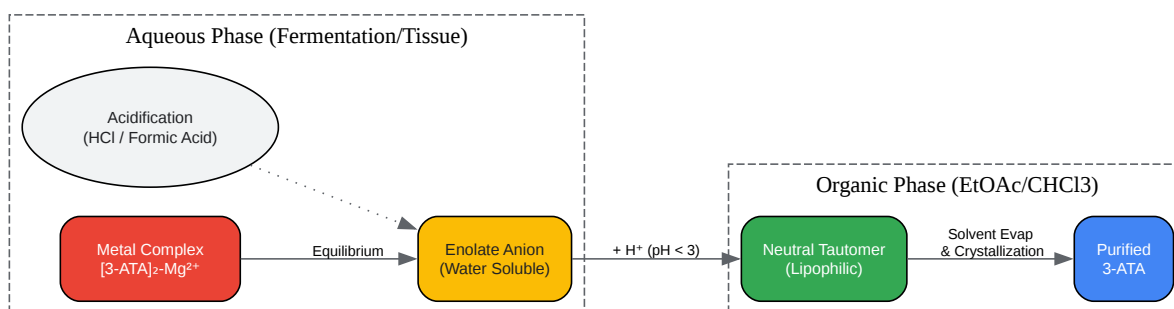

[Click to download full resolution via product page](#)

Caption: Acidification shifts the equilibrium from water-soluble chelates/anions to the lipophilic neutral tautomer, enabling organic phase transfer.

Protocol A: Liquid-Liquid Extraction (Fermentation Broth)

Best for: Fungal cultures (e.g., *Alternaria*, *Fusarium*) and bacterial broths.

Reagents & Equipment[2][3][4]

- Solvent: Ethyl Acetate (EtOAc) - Preferred for high recovery.

- Acid: 2N Hydrochloric Acid (HCl) or Formic Acid.
- Drying Agent: Anhydrous Sodium Sulfate (Na₂SO₄).^[1]
- Equipment: Separatory funnel, Rotary evaporator, pH meter.

Step-by-Step Workflow

- Harvest & Separation:
 - Filter fermentation broth through cheesecloth or centrifuge (5000 x g, 15 min) to separate Mycelia from Supernatant.
 - Note: 3-ATA is often excreted, but significant amounts may remain intracellular. Process both if yield is critical.
- Acidification (Critical Step):
 - Place the supernatant in a beaker with stirring.
 - Slowly add 2N HCl until pH reaches 2.0 – 3.0.
 - Why: This protonates the tetramic acid nitrogen and oxygen, breaking any Mg/Ca complexes formed during fermentation.
- Extraction:
 - Transfer acidified broth to a separatory funnel.
 - Add EtOAc (ratio 1:1 v/v). Shake vigorously for 3 minutes. Vent frequently.
 - Allow phases to separate. Collect the upper organic layer.
 - Repeat extraction 2 more times with fresh EtOAc.
- Mycelial Extraction (Optional):
 - Macerate wet mycelia in Acetone or MeOH (10 mL/g). Sonicate for 20 min.

- Filter, evaporate organic solvent, and re-dissolve residue in water.[2]
- Acidify to pH 2.0 and extract with EtOAc as above.
- Concentration:
 - Combine all EtOAc fractions.
 - Wash with minimal brine (saturated NaCl) to remove excess acid/water.
 - Dry over anhydrous Na₂SO₄ for 30 min. Filter.
 - Evaporate under reduced pressure (Rotavap) at < 40°C. Warning: Tetramic acids can be heat-sensitive.

Protocol B: Solid Phase Extraction (Complex Matrices)

Best for: Plant tissues (e.g., Tomato), food matrices, or cleaning up crude extracts.

Method: Modified QuEChERS (Quick, Easy, Cheap, Effective, Rugged, and Safe).

Step-by-Step Workflow

- Homogenization:
 - Weigh 10 g of sample. Add 10 mL of Acidified Acetonitrile (Acetonitrile + 1% Formic Acid).
 - Homogenize for 1 min (high speed).
- Salting Out:
 - Add 4 g MgSO₄ and 1 g NaCl.
 - Shake vigorously for 1 min. Centrifuge at 4000 rpm for 5 min.
 - Mechanism:[3][4][5][6] The salts force water out of the organic phase, while the low pH keeps 3-ATA in the acetonitrile layer.

- Cleanup (dSPE):
 - Transfer supernatant to a tube containing C18 sorbent (removes lipids) and PSA (Primary Secondary Amine) ONLY IF pH is controlled.
 - Caution: PSA is basic and can bind acidic 3-ATA. Use C18 only or ensure the extract remains acidified to prevent loss on amine sorbents.

Purification & Characterization

Chromatographic Purification

Crude extracts often contain fatty acids and phenols.

- Stationary Phase: Sephadex LH-20 (Size exclusion/Adsorption).
 - Eluent: 100% Methanol.
 - Why: Extremely effective for separating tetramic acids from fatty acids without irreversible adsorption.
- HPLC-Prep:
 - Column: C18 Reverse Phase.
 - Mobile Phase: Water/Acetonitrile with 0.1% Trifluoroacetic Acid (TFA).
 - Note: TFA is mandatory to suppress peak tailing caused by the acidic enol group.

Data Summary: Solvent Efficiency

Solvent System	Extraction Efficiency	Selectivity	Notes
EtOAc (pH 2)	High (85-95%)	Moderate	Standard method. Co-extracts some organic acids. [1] [3] [7] [8] [9] [10] [11]
CHCl ₃ (pH 2)	Moderate (60-75%)	High	Cleaner extracts but lower yield. Good for partitioning.
MeOH (Neutral)	High (>95%)	Low	Extracts everything (sugars, salts). Requires heavy downstream purification.

Diagram 2: Purification Logic Flow

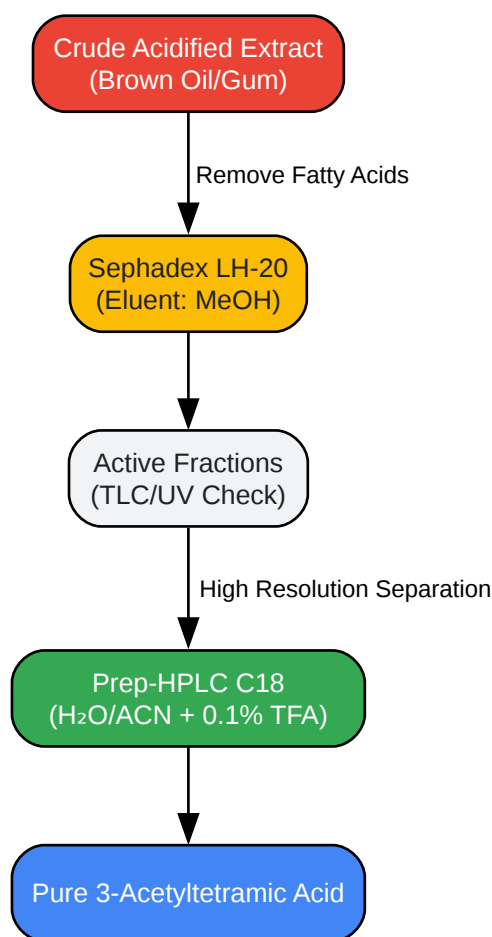

[Click to download full resolution via product page](#)

Caption: Downstream processing workflow prioritizing Sephadex LH-20 for initial cleanup followed by acidic HPLC.

Expert Troubleshooting & Validation

The "Copper Salt" Validation

A classical but highly reliable method to confirm the presence of 3-ATA (specifically Tenuazonic Acid type) is the formation of a copper complex.

- Test: Dissolve crude extract in MeOH. Add aqueous Copper Acetate.
- Result: A deep green or blue precipitate indicates the formation of the bis(3-acetyltetramate)copper(II) complex. This can be crystallized for X-ray diffraction.[11]

NMR Tautomerism Issues

- Symptom: ^1H NMR shows broad, split, or "messy" peaks.
- Cause: Slow exchange between exo-enol and endo-enol tautomers on the NMR timescale.
- Fix: Run NMR in DMSO- d_6 or Methanol- d_4 (promotes one tautomer) or heat the sample to 50°C to coalesce the signals.

Low Yield?

- Check pH: If the aqueous phase was not below pH 3.0, the compound remained in the water as a salt.
- Check Chelation: If the fermentation media was very high in Mg^{2+} or Fe^{3+} , standard acidification might need to be more aggressive, or EDTA (0.1M) can be added during the initial lysis to strip metals.

References

- Liu, Y., et al. (2022). "New 3-Acyl Tetramic Acid Derivatives from the Deep-Sea-Derived Fungus *Lecanicillium fusisporum*." *Marine Drugs*. Available at: [\[Link\]](#)
- Schlenk, A., et al. (2010).[7] "A Selective 3-acylation of Tetramic Acids and the First Synthesis of Ravenic Acid." *Chemistry – A European Journal*. Available at: [\[Link\]](#)
- Siegel, D., et al. (2009). "Naturally Occurring Tetramic Acids: Structure, Isolation, and Synthesis." *Natural Product Reports*. Available at: [\[Link\]](#)
- European Food Safety Authority. (2023). "LC-MS/MS Multi-Method for Tenuazonic Acid Determination." *Toxins*.[\[1\]](#)[\[2\]](#) Available at: [\[Link\]](#)
- Scott, P.M. (2001). "Analysis of agricultural commodities and foods for *Alternaria* mycotoxins." *Journal of AOAC International*. (Standard reference for acidic extraction protocols).

Need Custom Synthesis?

BenchChem offers custom synthesis for rare earth carbides and specific isotopic labeling.

Email: info@benchchem.com or [Request Quote Online](#).

Sources

- [1. agritrop.cirad.fr](http://1.agritrop.cirad.fr) [agritrop.cirad.fr]
- [2. ingenieria-analitica.com](http://2.ingenieria-analitica.com) [ingenieria-analitica.com]
- [3. researchgate.net](http://3.researchgate.net) [researchgate.net]
- [4. CN107281778B - Extraction separation method of organic acid - Google Patents](#) [patents.google.com]
- [5. scispace.com](http://5.scispace.com) [scispace.com]
- [6. mdpi.com](http://6.mdpi.com) [mdpi.com]
- [7. A selective 3-acylation of tetramic acids and the first synthesis of ravenic acid - PubMed](#) [pubmed.ncbi.nlm.nih.gov]
- [8. pubs.acs.org](http://8.pubs.acs.org) [pubs.acs.org]
- [9. researchgate.net](http://9.researchgate.net) [researchgate.net]
- [10. halo.science](http://10.halo.science) [halo.science]
- [11. mdpi.com](http://11.mdpi.com) [mdpi.com]
- To cite this document: BenchChem. [Advanced Extraction & Purification Protocols for 3-Acetyltetramic Acid[1]]. BenchChem, [2026]. [Online PDF]. Available at: [<https://www.benchchem.com/product/b069421/docs#advanced-extraction-purification-protocols-for-3-acetyltetramic-acid-1>]

Disclaimer & Data Validity:

The information provided in this document is for Research Use Only (RUO) and is strictly not intended for diagnostic or therapeutic procedures. While BenchChem strives to provide accurate protocols, we make no warranties, express or implied, regarding the fitness of this product for every specific experimental setup.

Technical Support: The protocols provided are for reference purposes. Unsure if this reagent suits your experiment?

Need Industrial/Bulk Grade? [Request Custom Synthesis Quote](#)

BenchChem

Our mission is to be the trusted global source of essential and advanced chemicals, empowering scientists and researchers to drive progress in science and industry.

Contact

Address: 3281 E Guasti Rd
Ontario, CA 91761, United States
Phone: (601) 213-4426
Email: info@benchchem.com

[Contact our Ph.D. Support Team for a compatibility check](#)