

Technical Support Center: Optimizing Aminopyrimidine Synthesis

Author: BenchChem Technical Support Team. **Date:** April 2026

Compound of Interest

Compound Name: 2-Amino-5-butyl-6-(methoxymethyl)pyrimidin-4-ol
CAS No.: 175137-37-8
Cat. No.: B068646

[Get Quote](#)

Prepared by: Gemini, Senior Application Scientist

Welcome to the technical support center for aminopyrimidine synthesis. This guide is designed for researchers, scientists, and drug development professionals to navigate the complexities of these critical reactions. Aminopyrimidines are a cornerstone in medicinal chemistry, forming the core of numerous therapeutic agents.^{[1][2]} However, their synthesis can be fraught with challenges, from low yields to unexpected side reactions. This resource provides in-depth, field-proven insights in a troubleshooting-focused Q&A format to help you optimize your reaction conditions and achieve your desired synthetic outcomes.

Section 1: General Troubleshooting & FAQs

This section addresses broad, common issues encountered during the synthesis of aminopyrimidines.

Q1: My reaction yield is consistently low. What are the most common culprits?

Low yield is a frequent issue stemming from several factors. A systematic approach to troubleshooting is essential. The primary areas to investigate are the quality of starting materials, the reaction conditions, and the work-up procedure.

Causality: The classical synthesis, often a Pinner-type reaction, involves the condensation of a 1,3-dicarbonyl compound (or equivalent) with an amidine.^{[3][4]} This is an equilibrium-driven process where incomplete conversion, degradation of reactants or products, and side reactions directly impact the final yield.

Troubleshooting Guide: Low Reaction Yields

Symptom	Potential Cause	Recommended Action & Explanation
Reaction stalls (TLC monitoring shows no change)	1. Impure Starting Materials: Moisture or impurities in 1,3-dicarbonyls or amidine salts can inhibit the reaction.	Action: Recrystallize or re-purify starting materials. Dry solvents rigorously. Guanidine hydrochloride, for example, is hygroscopic and should be stored in a desiccator.
2. Inappropriate Base/Acid: The choice and stoichiometry of the base (e.g., K ₂ CO ₃ , NaOMe) or acid catalyst are critical for activating the substrates.[3][5]	Action: Screen different bases/acids. For Pinner-type syntheses, a base is typically used to deprotonate the amidine salt. Ensure at least stoichiometric amounts are used.	
3. Sub-optimal Temperature: Condensation reactions often require sufficient thermal energy to overcome the activation barrier, but excessive heat can cause degradation.	Action: Incrementally increase the reaction temperature while monitoring by TLC. Consider switching to microwave-assisted synthesis for rapid heating and precise temperature control.[6]	
Multiple spots on TLC, low yield of desired product	1. Side Reactions: Competing reactions, such as self-condensation of the dicarbonyl compound, are common.	Action: Adjust the rate of addition of reagents. Adding the amidine solution slowly to the dicarbonyl compound can minimize its self-condensation.
2. Product Degradation: The aminopyrimidine product may be unstable under prolonged heating or acidic/basic conditions.	Action: Reduce the reaction time. Once TLC indicates maximum product formation, proceed immediately to work-up. Neutralize the reaction mixture carefully during extraction.	

3. Dimroth Rearrangement: An undesired Dimroth rearrangement can lead to an isomeric, and often inseparable, aminopyrimidine product.[7]	Action: See Section 2 for a detailed guide on controlling this rearrangement. This is a critical consideration, especially in fused-ring systems.	
Good conversion by TLC, but low isolated yield	1. Product Solubility: The product may be partially soluble in the aqueous phase during work-up or too soluble in the recrystallization solvent.	Action: Perform extractions with a different organic solvent. For polar products, a continuous liquid-liquid extraction may be necessary. For recrystallization, screen a range of solvent systems.
2. Adsorption on Silica Gel: Aminopyrimidines, being basic, can strongly adhere to silica gel during column chromatography, leading to poor recovery.	Action: Pre-treat the silica gel with triethylamine (e.g., in the eluent system, typically 0.5-1% v/v) to neutralize acidic sites and improve product elution.	

Q2: I'm observing an unexpected isomer in my final product. Could this be the Dimroth rearrangement?

Yes, this is a very likely possibility. The Dimroth rearrangement is a common isomerization event in nitrogen-containing heterocycles, including pyrimidines, where endocyclic and exocyclic nitrogen atoms effectively switch places.[8][9] It can occur as an undesired side reaction, leading to complex mixtures and incorrect structural assignments.[7]

Causality: The rearrangement proceeds through a ring-opening/ring-closing mechanism, often catalyzed by acid, base, or even heat.[9][10] The reaction is typically driven by the formation of a thermodynamically more stable isomer. Factors like pH and the electronic nature of substituents on the pyrimidine ring heavily influence the rate of rearrangement.[7][9] For instance, electron-withdrawing groups can increase the rate by making the pyrimidine ring more susceptible to nucleophilic attack, which initiates the ring-opening sequence.[11][12]

Visualizing the Dimroth Rearrangement Mechanism:

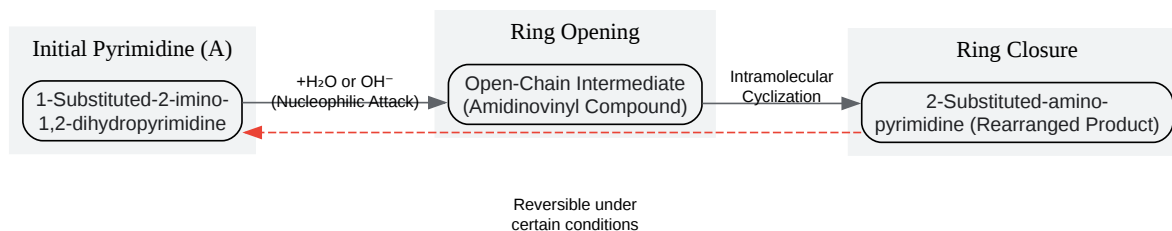

[Click to download full resolution via product page](#)

Caption: The Dimroth rearrangement pathway.

Section 2: Troubleshooting Specific Synthetic Routes

Route 1: Pinner-Type Condensation (1,3-Dicarbonyl + Amidine)

This is one of the most fundamental and widely used methods for constructing the pyrimidine core.^[3]

Q: What is the best solvent for a Pinner-type synthesis?

There is no single "best" solvent; the optimal choice depends on the solubility of your substrates and the reaction temperature.

Expertise & Experience: The solvent must fully dissolve the reactants at the reaction temperature to ensure a homogeneous reaction mixture. Alcohols like ethanol and isopropanol are common choices as they are polar enough to dissolve amidine salts (like guanidine hydrochloride) and are suitable for reflux temperatures.^[13] For higher temperatures, solvents like DMF or dioxane can be used.^{[3][14]} However, be aware that solvent polarity can influence reaction pathways and the rate of side reactions.^{[15][16][17]}

Protocol: General Procedure for 2-Aminopyrimidine Synthesis

- Setup: In a round-bottom flask equipped with a reflux condenser, dissolve the 1,3-dicarbonyl compound (1.0 eq) in a suitable solvent (e.g., ethanol, 5-10 mL per mmol of dicarbonyl).

- Reagent Addition: Add a base (e.g., sodium methoxide, 2.2 eq) to the solution, followed by the amidine salt (e.g., guanidine hydrochloride, 1.2 eq).[13]
- Reaction: Heat the mixture to reflux. The reaction time can vary significantly (from a few hours to 48 hours) depending on the substrates.[13]
- Monitoring: Monitor the reaction progress by Thin-Layer Chromatography (TLC). Use a suitable eluent system (e.g., ethyl acetate/hexane) to resolve the starting material and product.
- Work-up: After cooling to room temperature, remove the solvent under reduced pressure. Add distilled water to the residue and extract the product with an organic solvent (e.g., ethyl acetate, 3x).[13]
- Purification: Dry the combined organic layers over anhydrous Na_2SO_4 , filter, and concentrate. Purify the crude product by recrystallization or column chromatography.[18]

Route 2: Microwave-Assisted Synthesis

Microwave-assisted organic synthesis (MAOS) has become a powerful tool for accelerating aminopyrimidine synthesis.[6]

Q: When should I consider using microwave synthesis over conventional heating?

Consider MAOS when conventional methods result in long reaction times, low yields, or significant product degradation.

Causality: Microwave irradiation directly and rapidly heats the reaction mixture by interacting with polar molecules, leading to a dramatic reduction in reaction times—often from hours to minutes.[6] This rapid heating can also minimize the formation of degradation byproducts that occur during prolonged exposure to high temperatures. Many reactions can also be performed under solvent-free conditions, which is a significant advantage for green chemistry.[6][19][20]

Data Presentation: Microwave vs. Conventional Heating

Parameter	Microwave-Assisted Synthesis	Conventional Heating	Reference
Reaction Time	5-20 minutes	8-24 hours	[6]
Typical Yield	Often higher (e.g., 85-95%)	Variable, often lower	[6]
Conditions	Precise T/P control, solvent-free options	Bulk heating, requires solvent	[6][19]
Energy Efficiency	High	Low	[6]

Visualizing the MAOS Workflow:

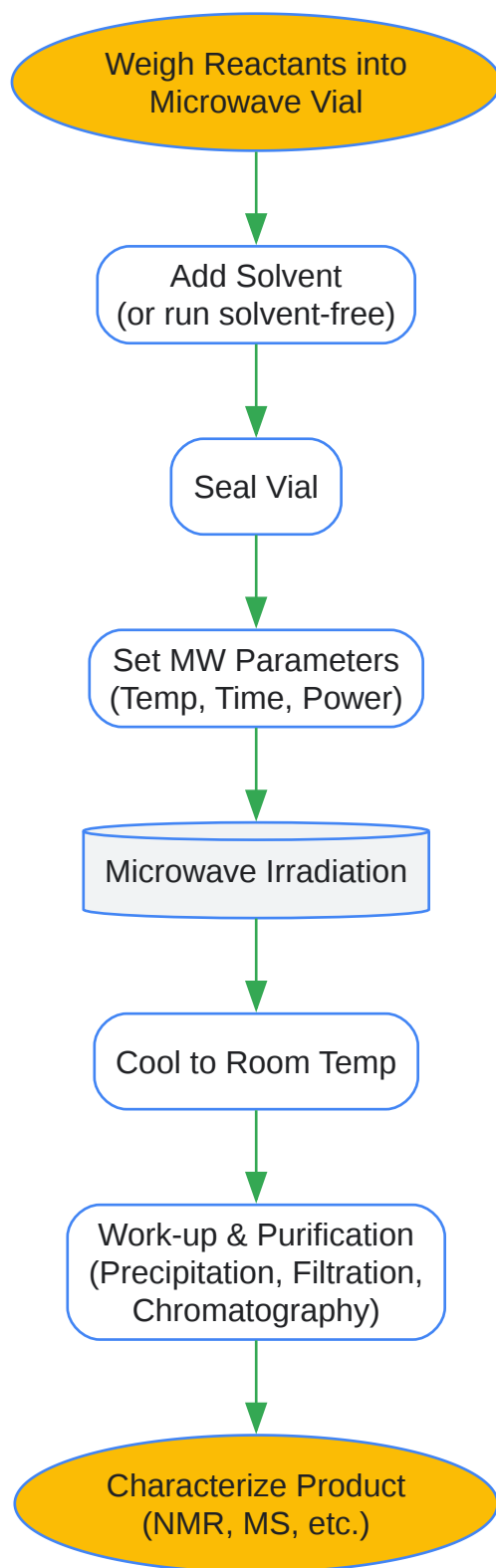

[Click to download full resolution via product page](#)

Caption: A typical workflow for microwave-assisted synthesis.

Section 3: Purification and Characterization

Q: My aminopyrimidine product is a sticky oil that is difficult to purify by column chromatography. What can I do?

This is a common issue, especially with highly substituted or lower molecular weight aminopyrimidines.

- **Salt Formation:** Attempt to form a salt (e.g., hydrochloride or trifluoroacetate). Dissolve the crude oil in a minimal amount of a suitable solvent (like diethyl ether or ethyl acetate) and add a solution of HCl in ether or neat TFA dropwise. The resulting crystalline salt can often be easily filtered and washed. The free base can be regenerated later if needed.
- **Trituration:** This is a technique to induce crystallization. Add a poor solvent (a solvent in which your product is insoluble, like hexane or pentane) to the oil and scratch the inside of the flask with a glass rod. Sonication can also help induce crystallization.
- **Alternative Chromatography:** If silica gel is problematic due to the basicity of the compound, consider using neutral or basic alumina as the stationary phase. Alternatively, reverse-phase chromatography (C18) can be effective for polar aminopyrimidines.
- **Kugelrohr Distillation:** For non-crystalline, thermally stable products, short-path distillation using a Kugelrohr apparatus can be an excellent purification method, especially if the impurities are non-volatile.

References

- Direct synthesis of 5- and 6-substituted 2-aminopyrimidines as potential non-natural nucleobase analogues. RSC Advances. Available at: [\[Link\]](#)
- Microwave-Assisted One-Pot Synthesis of Aminopyrimidine Scaffolds and their Biological Evaluation. Letters in Applied NanoBioScience. Available at: [\[Link\]](#)
- Synthesis and Antiplatelet Aggregation Activity Evaluation of some 2-Aminopyrimidine and 2-Substituted-4,6-diaminopyrimidine Derivatives. Brieflands. Available at: [\[Link\]](#)
- Synthesis, Characterization and Antimicrobial Activities of Some New Amino-Pyrimidine Derivatives. Research Journal of Pharmacy and Technology. Available at: [\[Link\]](#)

- Synthesis of Substituted Aminopyrimidines as Novel Promising Tyrosine Kinase Inhibitors. ResearchGate. Available at: [\[Link\]](#)
- Unexpected Observation of the Dimroth Rearrangement in the Ribosylation of 4-Aminopyrimidines. The Journal of Organic Chemistry. Available at: [\[Link\]](#)
- Dimroth rearrangement. Wikipedia. Available at: [\[Link\]](#)
- Catalyzed Methods to Synthesize Pyrimidine and Related Heterocyclic Compounds. MDPI. Available at: [\[Link\]](#)
- Synthesis of 2-Aminopyrimidine Derivatives and Their Evaluation as β -Glucuronidase Inhibitors: In Vitro and In Silico Studies. MDPI. Available at: [\[Link\]](#)
- Unexpected Observation of the Dimroth Rearrangement in the Ribosylation of 4-Aminopyrimidines. ACS Publications. Available at: [\[Link\]](#)
- An overview of the 2- Aminopyrimidine derivatives as antimicrobial agents. World Journal of Advanced Research and Reviews. Available at: [\[Link\]](#)
- The Dimroth Rearrangement in the Synthesis of Condensed Pyrimidines – Structural Analogs of Antiviral Compounds. SpringerLink. Available at: [\[Link\]](#)
- The Simple and Efficient Method of Synthesis of Amino Pyrimidine and Their Derivatives. Hindawi. Available at: [\[Link\]](#)
- Dimroth's Rearrangement as a Synthetic Strategy Towards New Heterocyclic Compounds. Bentham Science. Available at: [\[Link\]](#)
- Pinner pyrimidine synthesis. Slideshare. Available at: [\[Link\]](#)
- Solvation of aminopyridines by water and methanol. Canadian Science Publishing. Available at: [\[Link\]](#)
- Reactions of N-Aminopyrimidine Derivatives with 1,3-Dicarbonyl Compounds. TÜBİTAK Academic Journals. Available at: [\[Link\]](#)

- Purification and biological-testing of a novel synthesis method of 2-Aminopyrimidines. YouTube. Available at: [\[Link\]](#)
- The Dimroth Rearrangement: A Comprehensive Analysis. Star Chemistry. Available at: [\[Link\]](#)
- Recent Approaches to the Synthesis of Pyrimidine Derivatives. ResearchGate. Available at: [\[Link\]](#)
- Straightforward Novel One-Pot Enaminone and Pyrimidine Syntheses by Coupling-Addition-Cyclocondensation Sequences. Semantic Scholar. Available at: [\[Link\]](#)
- The Dimroth rearrangement. III. Formation of 2-Hydroxypyrimidine from 1,2-Dihydro-2-imino-1-methylpyrimidine. R Discovery. Available at: [\[Link\]](#)
- Novel Recyclable Catalysts for Selective Synthesis of Substituted Perimidines and Aminopyrimidines. ResearchGate. Available at: [\[Link\]](#)
- Strategies for the synthesis of unsymmetrical 2-aminopyrimidine. ResearchGate. Available at: [\[Link\]](#)
- Synthetic strategies of heterocycle-integrated pyridopyrimidine scaffolds supported by nano-catalysts. RSC Advances. Available at: [\[Link\]](#)
- Methods and routines for the synthesis of β -enaminonitriles and its related 4-aminopyrimidines, 4-amidinopyrimidines. ResearchGate. Available at: [\[Link\]](#)
- Dimroth's Rearrangement as a Synthetic Strategy Towards New Heterocyclic Compounds. ResearchGate. Available at: [\[Link\]](#)
- Postulated mechanism of the Dimroth rearrangement under basic conditions in the imidazo[1,2-a]pyrimidine ring. ResearchGate. Available at: [\[Link\]](#)
- Enaminones as Building Blocks for the Synthesis of Substituted Pyrazoles with Antitumor and Antimicrobial Activities. PMC. Available at: [\[Link\]](#)
- Synthesis and Characterization of Functionalized Amino Dihydropyrimidines Toward the Analysis of their Antibacterial Structure–Activity Relationships and Mechanism of Action.

ACS Omega. Available at: [\[Link\]](#)

- Recent advances in site-selective transformations of β -enaminones via transition-metal-catalyzed C–H functionalization/annulation. *Organic & Biomolecular Chemistry*. Available at: [\[Link\]](#)
- Investigation into Solubility and Solvent Effect of 2-Aminopyridine in Different Mono-Solvents Over Temperatures from 273.15 to 313.15 K. ACS Publications. Available at: [\[Link\]](#)
- Synthesis, Characterization and Solvent Effects on the Electronic Absorption Spectra of Aminopyridine Schiff Bases. ResearchGate. Available at: [\[Link\]](#)
- Investigation into Solubility and Solvent Effect of 2-Aminopyridine in Different Mono-Solvents Over Temperatures from 273.15 to 313.15 K. *Journal of Chemical & Engineering Data*. Available at: [\[Link\]](#)
- New 2-aminopyrimidine derivatives and their antitrypanosomal and antiplasmodial activities. ResearchGate. Available at: [\[Link\]](#)

Need Custom Synthesis?

BenchChem offers custom synthesis for rare earth carbides and specific isotopic labeling.

Email: info@benchchem.com or [Request Quote Online](#).

Sources

- [1. mdpi.com \[mdpi.com\]](#)
- [2. ijpsjournal.com \[ijpsjournal.com\]](#)
- [3. Catalyzed Methods to Synthesize Pyrimidine and Related Heterocyclic Compounds \[mdpi.com\]](#)
- [4. Pinner pyrimidine synthesis | PPTX \[slideshare.net\]](#)
- [5. researchgate.net \[researchgate.net\]](#)
- [6. pdf.benchchem.com \[pdf.benchchem.com\]](#)
- [7. starchemistry888.com \[starchemistry888.com\]](#)

- [8. Dimroth rearrangement - Wikipedia \[en.wikipedia.org\]](#)
- [9. The Dimroth Rearrangement in the Synthesis of Condensed Pyrimidines – Structural Analogs of Antiviral Compounds - PMC \[pmc.ncbi.nlm.nih.gov\]](#)
- [10. pubs.acs.org \[pubs.acs.org\]](#)
- [11. pubs.acs.org \[pubs.acs.org\]](#)
- [12. researchgate.net \[researchgate.net\]](#)
- [13. brieflands.com \[brieflands.com\]](#)
- [14. The Simple and Efficient Method of Synthesis of Amino Pyrimidine and Their Derivatives, American Journal of Heterocyclic Chemistry, Science Publishing Group \[sciencepublishinggroup.com\]](#)
- [15. cdnsciencepub.com \[cdnsciencepub.com\]](#)
- [16. researchgate.net \[researchgate.net\]](#)
- [17. pubs.acs.org \[pubs.acs.org\]](#)
- [18. pubs.acs.org \[pubs.acs.org\]](#)
- [19. Direct synthesis of 5- and 6-substituted 2-aminopyrimidines as potential non-natural nucleobase analogues - RSC Advances \(RSC Publishing\) \[pubs.rsc.org\]](#)
- [20. rjptonline.org \[rjptonline.org\]](#)
- To cite this document: BenchChem. [Technical Support Center: Optimizing Aminopyrimidine Synthesis]. BenchChem, [2026]. [Online PDF]. Available at: [\[https://www.benchchem.com/product/b068646/docs#technical-support-center-optimizing-aminopyrimidine-synthesis\]](https://www.benchchem.com/product/b068646/docs#technical-support-center-optimizing-aminopyrimidine-synthesis)

Disclaimer & Data Validity:

The information provided in this document is for Research Use Only (RUO) and is strictly not intended for diagnostic or therapeutic procedures. While BenchChem strives to provide accurate protocols, we make no warranties, express or implied, regarding the fitness of this product for every specific experimental setup.

Technical Support: The protocols provided are for reference purposes. Unsure if this reagent suits your experiment?

Need Industrial/Bulk Grade? [Request Custom Synthesis Quote](#)

BenchChem

Our mission is to be the trusted global source of essential and advanced chemicals, empowering scientists and researchers to drive progress in science and industry.

Contact

Address: 3281 E Guasti Rd

Ontario, CA 91761, United States

Phone: (601) 213-4426

Email: info@benchchem.com

[Contact our Ph.D. Support Team for a compatibility check](#)