

Application Notes and Protocols: Functionalized Calixarenes in Phase Transfer Catalysis

Author: BenchChem Technical Support Team. **Date:** April 2026

Compound of Interest

Compound Name: *Calix[4]-bis-2,3-naphtho-crown-6*

CAS No.: 162898-44-4

Cat. No.: B067664

[Get Quote](#)

For Researchers, Scientists, and Drug Development Professionals

This document provides detailed application notes and experimental protocols for the use of functionalized calixarenes as highly effective phase transfer catalysts in various organic transformations. The unique structural features of calixarenes, characterized by a hydrophobic cavity and modifiable upper and lower rims, allow for the design of catalysts with exceptional efficiency and selectivity.[1] These macrocyclic compounds have demonstrated significant potential in facilitating reactions between immiscible phases, a crucial aspect in the synthesis of pharmaceuticals and other fine chemicals.

This guide will focus on two key applications: nucleophilic fluorination and enantioselective alkylation, providing quantitative data for catalyst performance, detailed step-by-step protocols for catalyst synthesis and application, and visual diagrams of experimental workflows and catalytic cycles.

Application: Nucleophilic Fluorination

Nucleophilic fluorination is a critical transformation in the synthesis of fluorinated organic molecules, which are of great interest in medicinal chemistry and materials science. However, the low solubility of fluoride salts in organic solvents presents a significant challenge.

Functionalized calixarenes have emerged as powerful phase transfer catalysts to overcome this issue by effectively encapsulating the metal cation and transporting the "naked" and more reactive fluoride anion into the organic phase.

Featured Functionalized Calixarene Catalysts for Nucleophilic Fluorination

Several functionalized calixarenes have been developed for this purpose, with two notable examples being:

- Methylated bis-triethylene glycolic crown-5-calix[2]arene (M-BTC5A): This catalyst incorporates crown ether moieties and ethylene glycol chains, which work synergistically to dissolve and activate potassium fluoride (KF) in organic solvents.[1]
- Bis-tert-alcohol-functionalized crown-6-calix[2]arene (BACCA): This catalyst utilizes tertiary alcohol groups to activate the fluoride ion through hydrogen bonding, enhancing its nucleophilicity.

Quantitative Data: Performance of Calixarene Catalysts in Nucleophilic Fluorination

The following table summarizes the performance of M-BTC5A in the nucleophilic aromatic fluorination of a diaryliodonium salt precursor.

Catalyst	Solvent	Temperature (°C)	Time (min)	Yield (%)	Reference
M-BTC5A	DMF	120	30	75	[1]
M-BTC5A	CH ₃ CN	120	30	72	[1]
M-BTC5A	Dioxane	120	30	65	[1]
M-BTC5A	Toluene	120	30	58	[1]
M-BTC5A	DMSO	120	15	~82 (RCY)	[1]

Note: RCY refers to Radiochemical Yield for ¹⁸F-fluorination.

Experimental Protocols

This protocol is a representative synthesis of a crown-ether functionalized calixarene.

Workflow Diagram:

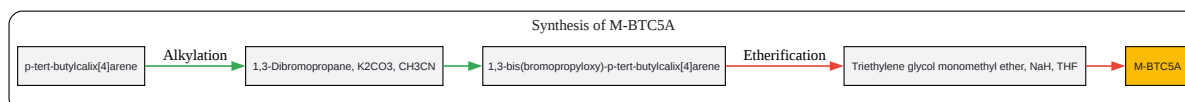

[Click to download full resolution via product page](#)

Caption: Synthesis workflow for M-BTC5A.

Materials:

- p-tert-butylcalix[2]arene
- 1,3-Dibromopropane
- Potassium carbonate (K₂CO₃)

- Anhydrous acetonitrile (CH_3CN)
- Triethylene glycol monomethyl ether
- Sodium hydride (NaH, 60% dispersion in mineral oil)
- Anhydrous tetrahydrofuran (THF)
- Standard glassware for organic synthesis (round-bottom flasks, condenser, dropping funnel, etc.)
- Magnetic stirrer and heating mantle
- Inert atmosphere (Nitrogen or Argon)

Procedure:

- Step 1: Synthesis of 1,3-bis(bromopropoxy)-p-tert-butylcalix[2]arene.
 - To a solution of p-tert-butylcalix[2]arene (1.0 eq) in anhydrous acetonitrile, add potassium carbonate (5.0 eq).
 - Heat the mixture to reflux under an inert atmosphere.
 - Slowly add a solution of 1,3-dibromopropane (2.2 eq) in anhydrous acetonitrile via a dropping funnel.
 - Continue refluxing for 24-48 hours, monitoring the reaction by TLC.
 - After completion, cool the reaction mixture to room temperature and filter to remove the inorganic salts.
 - Evaporate the solvent under reduced pressure.
 - Purify the crude product by column chromatography on silica gel (eluent: hexane/ethyl acetate) to obtain the desired intermediate.
- Step 2: Synthesis of M-BTC5A.

- To a suspension of sodium hydride (4.0 eq) in anhydrous THF under an inert atmosphere, slowly add triethylene glycol monomethyl ether (4.0 eq) at 0 °C.
- Stir the mixture at room temperature for 30 minutes.
- Add a solution of 1,3-bis(bromopropoxy)-p-tert-butylcalix[2]arene (1.0 eq) in anhydrous THF.
- Heat the reaction mixture to reflux for 12-24 hours, monitoring by TLC.
- After completion, cool the reaction to 0 °C and cautiously quench with water.
- Extract the product with dichloromethane.
- Wash the combined organic layers with brine, dry over anhydrous sodium sulfate, and concentrate under reduced pressure.
- Purify the crude product by column chromatography on silica gel (eluent: dichloromethane/methanol) to afford M-BTC5A as a white solid.

Catalytic Cycle Diagram:

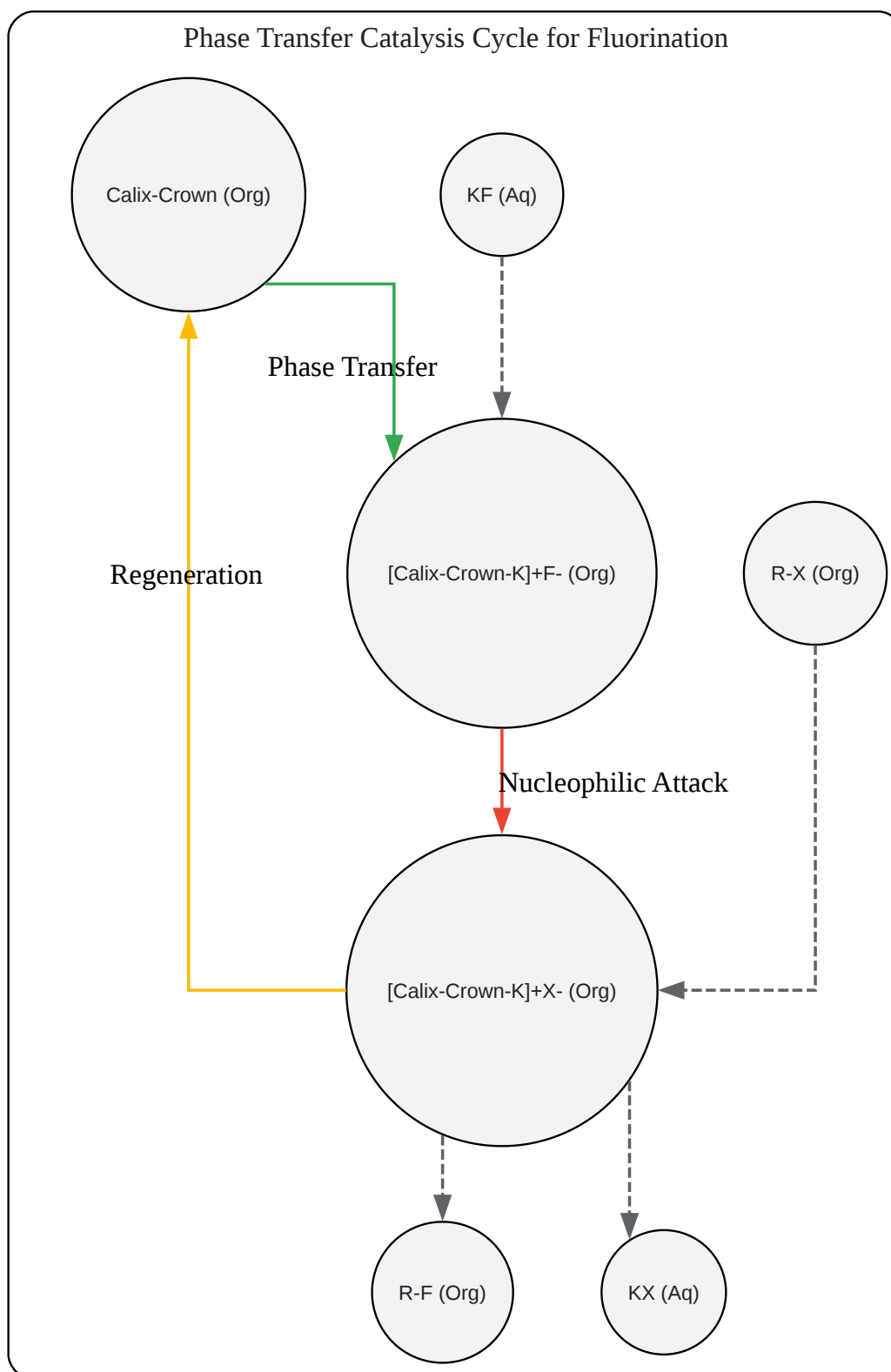

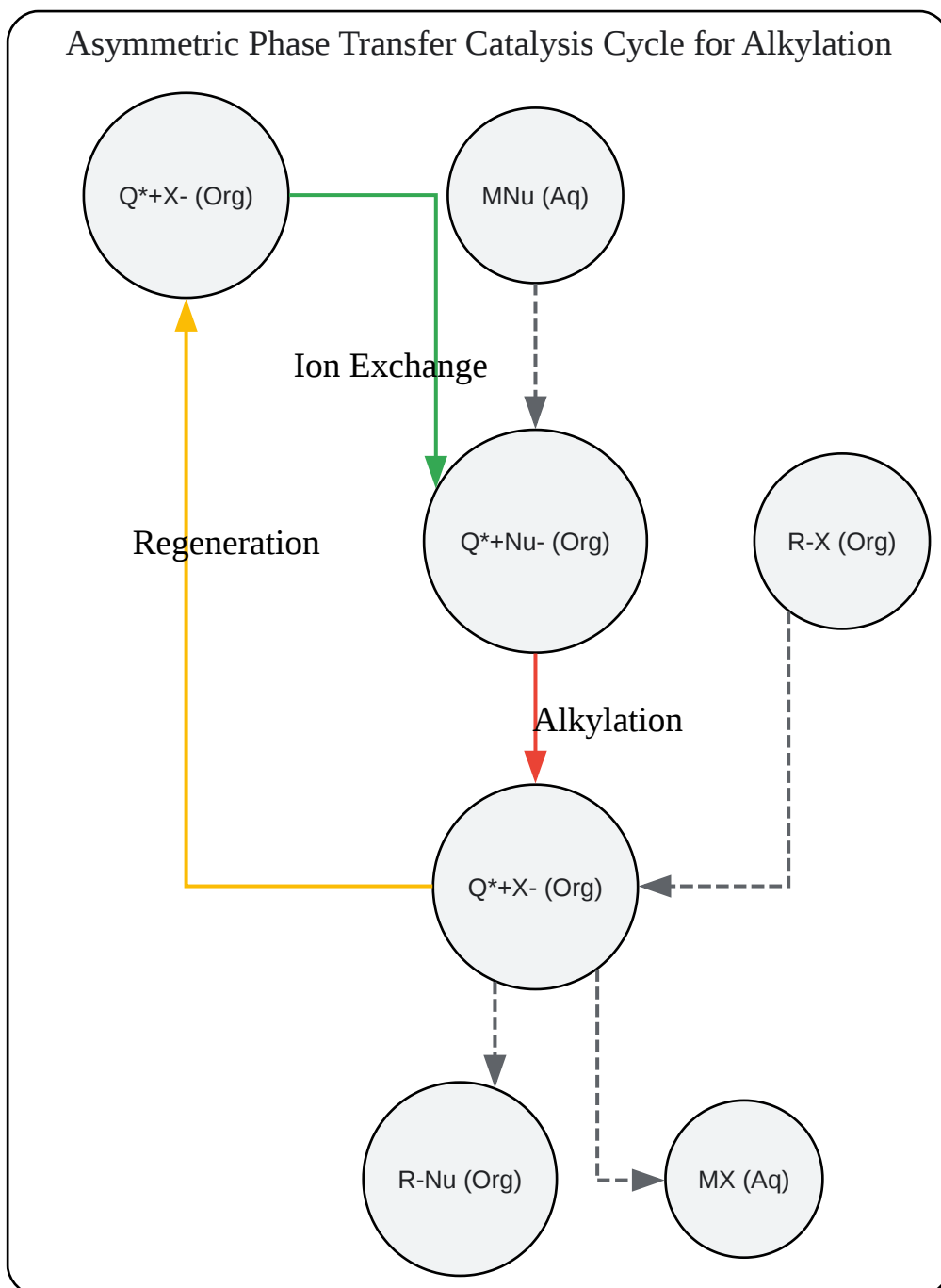
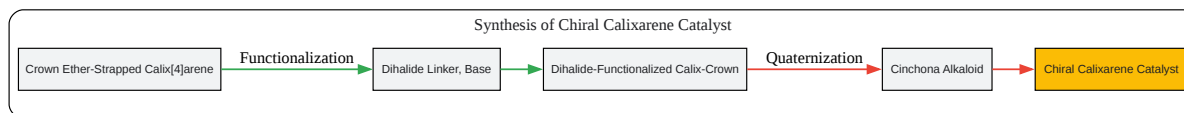

[Click to download full resolution via product page](#)

Need Custom Synthesis?

BenchChem offers custom synthesis for rare earth carbides and specific isotopic labeling.

Email: info@benchchem.com or [Request Quote Online](#).

References

- [1. researchgate.net \[researchgate.net\]](#)
- [2. researchgate.net \[researchgate.net\]](#)
- To cite this document: BenchChem. [Application Notes and Protocols: Functionalized Calixarenes in Phase Transfer Catalysis]. BenchChem, [2026]. [Online PDF]. Available at: [\[https://www.benchchem.com/product/b067664/docs#application-notes-and-protocols-functionalized-calixarenes-in-phase-transfer-catalysis\]](https://www.benchchem.com/product/b067664/docs#application-notes-and-protocols-functionalized-calixarenes-in-phase-transfer-catalysis)

Disclaimer & Data Validity:

The information provided in this document is for Research Use Only (RUO) and is strictly not intended for diagnostic or therapeutic procedures. While BenchChem strives to provide accurate protocols, we make no warranties, express or implied, regarding the fitness of this product for every specific experimental setup.

Technical Support: The protocols provided are for reference purposes. Unsure if this reagent suits your experiment?

Need Industrial/Bulk Grade? [Request Custom Synthesis Quote](#)

BenchChem

Our mission is to be the trusted global source of essential and advanced chemicals, empowering scientists and researchers to drive progress in science and industry.

Contact

Address: 3281 E Guasti Rd

Ontario, CA 91761, United States

Phone: (601) 213-4426

Email: info@benchchem.com

[Contact our Ph.D. Support Team for a compatibility check](#)