

Application Note: Advanced Methodologies for the Synthesis of Quinoline Derivatives

Author: BenchChem Technical Support Team. **Date:** April 2026

Compound of Interest

Compound Name: 2-bromo-2-(4-bromophenyl)acetonitrile

CAS No.: 748166-19-0

Cat. No.: B6600221

[Get Quote](#)

Introduction & Pharmacological Relevance

Quinoline derivatives represent a privileged heterocyclic scaffold in medicinal chemistry and drug development. They exhibit a broad spectrum of biological activities, including antimalarial, anticancer, antimicrobial, and anti-inflammatory properties[1]. For researchers and application scientists, selecting the appropriate synthetic route is critical for optimizing yield, accommodating sensitive functional groups, and scaling up production. This application note details three distinct, field-proven methodologies for quinoline synthesis, focusing on mechanistic causality, self-validating experimental designs, and robust troubleshooting metrics.

Mechanistic Insights: The Friedländer Annulation

The 2 remains one of the most straightforward and widely utilized methods for constructing the quinoline core[2]. It involves the cyclocondensation of a 2-aminoaryl aldehyde or ketone with a carbonyl compound containing a reactive α -methylene group[2]. Depending on the specific catalytic environment (acidic vs. basic), the reaction proceeds via two primary mechanistic pathways[2].

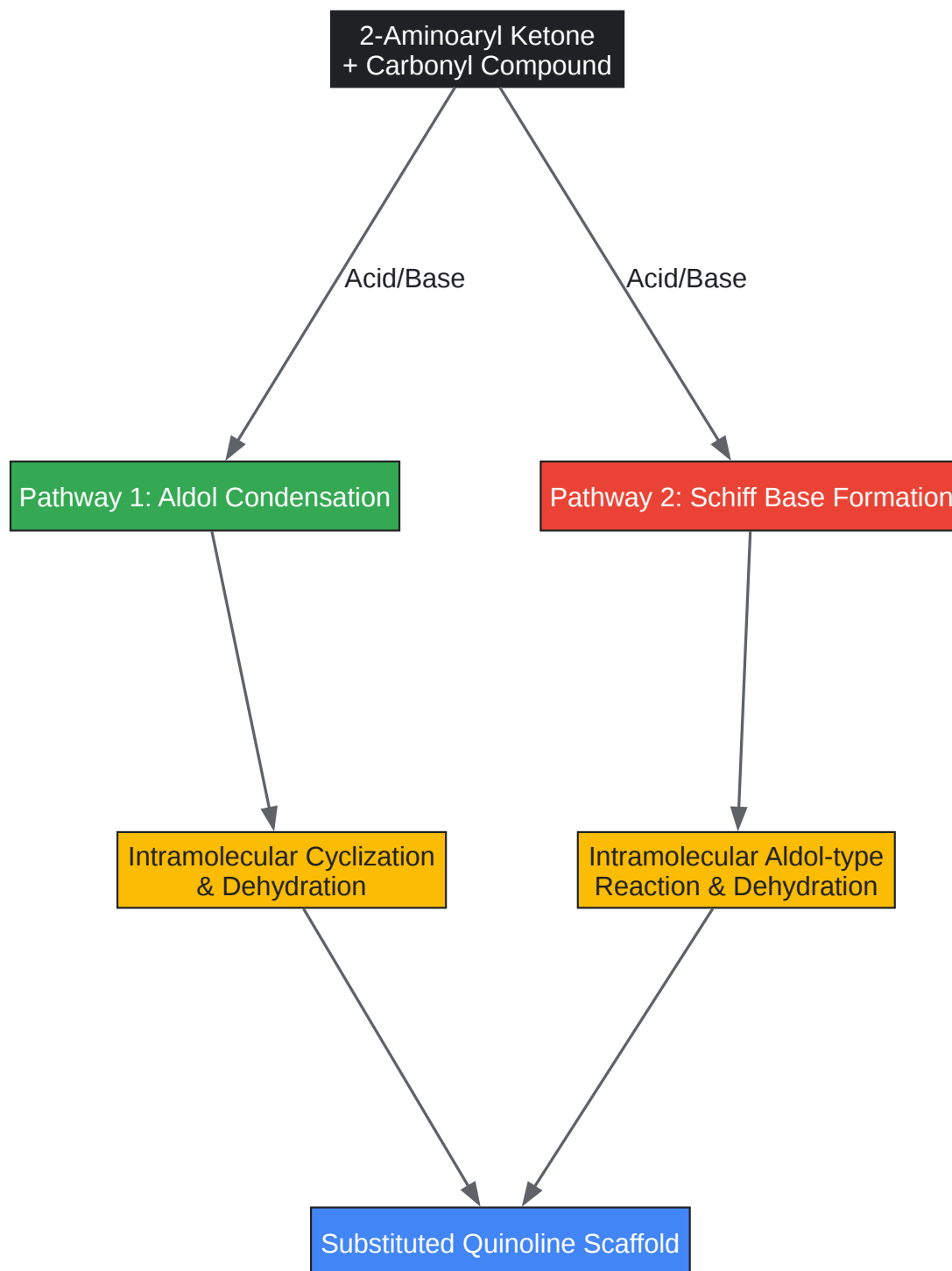

[Click to download full resolution via product page](#)

Mechanistic pathways of the Friedländer quinoline synthesis.

Experimental Protocols & Workflows

Protocol A: Solvent-Free Friedländer Synthesis (P₂O₅/SiO₂ Catalyzed)

This green chemistry approach eliminates toxic solvents and utilizes a solid-supported acid catalyst to drive the dehydration step forward[2].

- Causality of Design: Phosphorus pentoxide (P₂O₅) is a potent dehydrating agent but rapidly forms an intractable mass upon moisture exposure. Dispersing it on silica gel (SiO₂) maximizes the surface area, maintaining a free-flowing powder that facilitates optimal physical contact between solid or liquid reactants under solvent-free conditions[2].
- Procedure:
 - Catalyst Preparation: Thoroughly mix and grind silica gel (1.4 g) and P₂O₅ (0.6 g) in a mortar to obtain a fine, homogenous powder[2].
 - Reaction Setup: To a 25 mL round-bottom flask, add the 2-aminoaryl ketone (2 mmol), the α-methylene carbonyl compound (3 mmol), and the P₂O₅/SiO₂ catalyst (0.4 g)[2].
 - Execution: Heat the mixture at 80°C with constant stirring for 1–3 hours[2].
 - Workup: Cool to room temperature. Add chloroform (20 mL) and stir for 5 minutes to solubilize the organic product. Filter to remove the inorganic catalyst, wash the filter cake with chloroform (2 x 10 mL), and evaporate the combined filtrates under reduced pressure[2].
 - Purification: Purify via silica gel column chromatography (ethyl acetate/n-hexane)[2].
- Self-Validation & Diagnostics: The reaction is self-validating through physical state changes; the mixture will transition into a melt or paste as the condensation proceeds. If TLC indicates a stalled reaction, it strongly suggests moisture contamination has hydrolyzed and deactivated the P₂O₅ catalyst.

Protocol B: Domino Nitro Reduction-Friedländer Heterocyclization

A major limitation of the classical Friedländer synthesis is the instability and limited commercial availability of 2-aminobenzaldehydes[3]. This domino protocol circumvents the issue by utilizing highly stable 2-nitrobenzaldehydes[3].

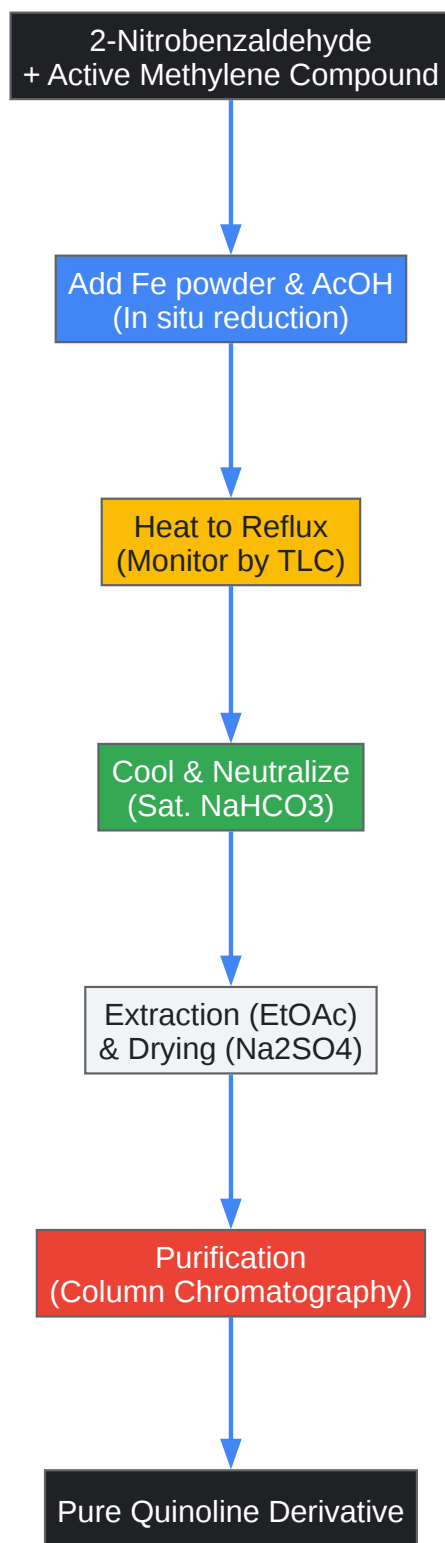

[Click to download full resolution via product page](#)

Experimental workflow for the domino nitro reduction-Friedländer heterocyclization.

- Causality of Design: [3](#) serves a dual purpose. It acts as a dissolving metal reducing agent to convert the nitro group to an amine [\[3\]](#). Simultaneously, the acidic environment catalyzes the Knoevenagel condensation between the carbonyls [\[3\]](#). Crucially, the double bond in the Knoevenagel intermediate is stable to Fe/AcOH, preventing unwanted over-reduction [\[3\]](#).
- Procedure:
 - Reaction Setup: In an oven-dried flask under N₂, dissolve 2-nitrobenzaldehyde (1.0 eq) and the active methylene compound (AMC) (1.2 eq) in glacial acetic acid [\[3\]](#).
 - Reduction Initiation: Add Iron (Fe) powder (3.0 eq) to the mixture [\[3\]](#).
 - Execution: Heat the mixture to reflux. The reaction typically reaches completion in 2-5 hours [\[3\]](#).
 - Workup: Cool to room temperature and carefully pour into saturated aqueous NaHCO₃ to neutralize the acetic acid [\[3\]](#). Extract with ethyl acetate (3 x 50 mL) [\[3\]](#).
 - Purification: Dry the combined organic layers over anhydrous Na₂SO₄, filter, concentrate, and purify via chromatography [\[3\]](#).
- Self-Validation & Diagnostics: TLC under 365 nm UV light will reveal the highly fluorescent quinoline product. If the Knoevenagel intermediate builds up without cyclizing, it indicates premature cooling. If the starting material remains unconsumed, the surface of the Fe powder may be oxidized; washing the Fe powder with dilute HCl prior to use restores its reductive capacity.

Protocol C: Large-Scale Oxidative Synthesis via HCl-DMSO

For industrial or large-scale applications, transition-metal-free systems utilizing simple reagents are preferred. The [4](#) allows for the direct synthesis of quinolines from carbonyl compounds and imines [\[4\]](#).

- Causality of Design: The reaction generates a 1,2-dihydroquinoline intermediate. Bubbling air through the DMSO solvent provides a mild, continuous oxidant that drives the

aromatization of the intermediate to the final quinoline, preventing the accumulation of amine byproducts[4].

- Procedure:
 - Reaction Setup: To a mixture of heptanal (50 mmol) and benzylideneaniline (60 mmol) in dry DMSO (150 mL), add HCl (4 M in dioxane) (0.625 mL, 2.5 mmol)[4].
 - Execution: Equip the flask with a drying tube and establish continuous air bubbling through the solution. Stir for 6 hours at 60 °C[4].
 - Workup: Pour the mixture into aqueous NaHCO₃ (50 mL) and water (500 mL). Extract with Et₂O (100 mL × 3)[4].
 - Purification: Dry over MgSO₄, concentrate, and purify[4].
- Self-Validation & Diagnostics: The presence of 1,2-dihydroquinoline or excessive amine byproducts on TLC indicates insufficient aeration[4]. Increasing the air flow rate directly resolves this bottleneck[4].

Quantitative Data & Catalyst Comparison

The following table summarizes the quantitative parameters and efficiencies of the discussed methodologies to aid in protocol selection:

Catalyst / System	Substrates	Reaction Conditions	Average Yield (%)	Key Advantages
P ₂ O ₅ /SiO ₂	2-Aminoaryl ketone + Carbonyl	80°C, Solvent-Free, 1–3 h	85–95%	Eco-friendly, simple non-extractive workup, high atom economy[2].
Chloramine-T	2-Aminoaryl ketone + Ketone	Acetonitrile reflux, 4 h	88–96%	Inexpensive catalyst, excellent functional group tolerance[5].
Fe / AcOH	2-Nitrobenzaldehyde + AMC	Reflux, 2–5 h	80–95%	Avoids unstable 2-aminobenzaldehydes; one-pot domino sequence[3].
HCl / DMSO	Carbonyls + Imines	60°C, Air bubbling, 6 h	75–85%	Highly scalable, utilizes simple and cheap reagents[4].

References

- Experimental Protocol for Friedländer Condensation: A Versatile Approach to Quinoline Synthesis. BenchChem. [2](#)
- Step-by-Step Friedländer Synthesis of Quinolines: Application Notes and Protocols for Researchers. BenchChem. [1](#)
- Domino Nitro Reduction-Friedländer Heterocyclization for the Preparation of Quinolines. Semantic Scholar. [3](#)

- Practical and Simple Synthesis of Substituted Quinolines by an HCl–DMSO System on a Large Scale: Remarkable Effect of the Chloride Ion. ACS Publications. [4](#)
- A simple and efficient protocol for the synthesis of quinolines catalyzed by chloramine-T. ACG Publications. [5](#)

Need Custom Synthesis?

BenchChem offers custom synthesis for rare earth carbides and specific isotopic labeling.

Email: info@benchchem.com or [Request Quote Online](#).

Sources

- [1. benchchem.com](https://www.benchchem.com) [[benchchem.com](https://www.benchchem.com)]
- [2. pdf.benchchem.com](https://pdf.benchchem.com) [pdf.benchchem.com]
- [3. pdfs.semanticscholar.org](https://pdfs.semanticscholar.org) [pdfs.semanticscholar.org]
- [4. pubs.acs.org](https://pubs.acs.org) [pubs.acs.org]
- [5. acgpubs.org](https://acgpubs.org) [acgpubs.org]
- To cite this document: BenchChem. [Application Note: Advanced Methodologies for the Synthesis of Quinoline Derivatives]. BenchChem, [2026]. [Online PDF]. Available at: [<https://www.benchchem.com/product/b6600221/docs#application-note-advanced-methodologies-for-the-synthesis-of-quinoline-derivatives>]

Disclaimer & Data Validity:

The information provided in this document is for Research Use Only (RUO) and is strictly not intended for diagnostic or therapeutic procedures. While BenchChem strives to provide accurate protocols, we make no warranties, express or implied, regarding the fitness of this product for every specific experimental setup.

Technical Support: The protocols provided are for reference purposes. Unsure if this reagent suits your experiment?

Need Industrial/Bulk Grade? [Request Custom Synthesis Quote](#)

BenchChem

Our mission is to be the trusted global source of essential and advanced chemicals, empowering scientists and researchers to drive progress in science and industry.

Contact

Address: 3281 E Guasti Rd

Ontario, CA 91761, United States

Phone: (601) 213-4426

Email: info@benchchem.com

[Contact our Ph.D. Support Team for a compatibility check](#)