

In Silico Docking of Pyrazole-Based Inhibitors: A Technical Guide

Author: BenchChem Technical Support Team. **Date:** April 2026

Compound of Interest

Compound Name: 3-(4-Aminophenyl)-4-bromo-1-methylpyrazole

CAS No.: 175276-41-2

Cat. No.: B066816

[Get Quote](#)

Authored for Researchers, Scientists, and Drug Development Professionals

Abstract

The pyrazole scaffold is a privileged structure in medicinal chemistry, forming the core of numerous inhibitors targeting a wide array of protein classes. In silico molecular docking has emerged as an indispensable tool in the rational design and optimization of these pyrazole-based inhibitors. This technical guide provides an in-depth overview of the computational methodologies, key findings, and signaling pathways associated with pyrazole inhibitors of various protein targets. Quantitative data from recent studies are summarized, detailed experimental protocols for in silico analyses are provided, and critical biological pathways are visualized to offer a comprehensive resource for researchers in the field of drug discovery.

Introduction

Pyrazole and its derivatives are five-membered heterocyclic compounds that have garnered significant attention in medicinal chemistry due to their diverse pharmacological activities.^[1] These activities include anti-inflammatory, anticancer, and antimicrobial effects. The versatility

of the pyrazole ring allows for substitutions at various positions, enabling the fine-tuning of steric and electronic properties to achieve high affinity and selectivity for specific biological targets.

Computational methods, particularly molecular docking, have accelerated the discovery and development of pyrazole-based drugs.[1] These in silico techniques predict the binding mode and affinity of a small molecule (ligand) to the active site of a target protein, providing valuable insights into the molecular basis of inhibition. This guide will delve into the practical aspects of performing and interpreting docking studies of pyrazole-based inhibitors against several important protein targets.

Key Protein Targets for Pyrazole-Based Inhibitors

A number of studies have successfully employed in silico docking to identify and characterize pyrazole-based inhibitors for a variety of protein targets critical in disease pathogenesis.

Protein Kinases

Protein kinases are a large family of enzymes that play crucial roles in cellular signaling, and their dysregulation is a hallmark of many diseases, including cancer. Several classes of protein kinases have been effectively targeted by pyrazole-based inhibitors.

- VEGFR-2 (Vascular Endothelial Growth Factor Receptor 2): A key mediator of angiogenesis, the formation of new blood vessels, which is essential for tumor growth and metastasis.[2]
- Aurora A Kinase: A serine/threonine kinase involved in mitotic progression, whose overexpression is linked to various cancers.[3]
- CDK2 (Cyclin-Dependent Kinase 2): A critical regulator of the cell cycle, particularly the G1/S phase transition. Its aberrant activity is often observed in cancer cells.[4]
- RET (Rearranged during Transfection) Kinase: A receptor tyrosine kinase whose mutations and rearrangements are associated with several types of cancer, including thyroid and lung cancer.[2][5][6]

Other Important Drug Targets

- COX-2 (Cyclooxygenase-2): An enzyme responsible for the production of prostaglandins, which are key mediators of inflammation and pain.[7][8]
- Tubulin: The protein subunit of microtubules, which are essential components of the cytoskeleton and the mitotic spindle. Tubulin inhibitors are potent anticancer agents.
- HPPD (4-Hydroxyphenylpyruvate Dioxygenase): An enzyme involved in tyrosine metabolism, which is a target for herbicides and is being explored for the treatment of certain metabolic disorders.[9][10]

Quantitative Docking Data of Pyrazole-Based Inhibitors

The following tables summarize the quantitative data from various in silico docking studies of pyrazole-based inhibitors against their respective protein targets. These tables are intended to provide a comparative overview of the reported binding affinities and inhibitory activities.

Table 1: Docking Scores and Binding Energies of Pyrazole-Based Kinase Inhibitors

Inhibitor	Target Protein	PDB ID	Docking Score (kcal/mol)	Binding Energy (kJ/mol)	Key Interacting Residues	Reference
Pyrazole Derivative 1b	VEGFR-2	2QU5	-	-10.09	Not specified	[5]
Pyrazole Derivative 1d	Aurora A	2W1G	-	-8.57	Not specified	[5]
Pyrazole Derivative 2b	CDK2	2VTO	-	-10.35	Ile10, Lys20, Lys89, Asp145	[5]
Compound 5o	Tubulin	1SA0	-7.22	-	ASN 249, ALA 250, LYS 254	[3]
Compound 25	RET Kinase	Not Specified	-7.14	-	Ala807	[11]

Table 2: Docking Data for Pyrazole-Based Inhibitors of Other Targets

Inhibitor	Target Protein	PDB ID	Docking Score (kcal/mol)	Binding Energy (kcal/mol)	Key Interacting Residues	Reference
Pyrazole-benzimidazole 12	HPPD	Not Specified	-	-	GLN 307, ASN 423, PHE 392	[6]
Pyrazole Derivative M74	CRMP2	6JV9	-6.9	-	Not specified	[12]
Pyrazole Derivative M72	CYP17	Not Specified	-10.4	-	Not specified	[12]

Experimental Protocols for In Silico Docking

A standardized and rigorous protocol is essential for obtaining reliable and reproducible results in molecular docking studies. The following sections outline a detailed methodology for performing molecular docking using AutoDock, a widely used and freely available software suite.

Preparation of the Receptor Protein

- Obtain Protein Structure: Download the 3D structure of the target protein from the Protein Data Bank (PDB).
- Pre-processing: Remove water molecules, co-factors, and any co-crystallized ligands from the PDB file.
- Add Hydrogens: Add polar hydrogen atoms to the protein structure.
- Assign Charges: Compute and assign partial charges to the protein atoms (e.g., Gasteiger charges).
- Define Atom Types: Assign AutoDock atom types to all atoms.

- **Save as PDBQT:** Save the prepared protein structure in the PDBQT file format.

Preparation of the Pyrazole-Based Ligand

- **Ligand Structure:** Draw the 2D structure of the pyrazole derivative using a chemical drawing software (e.g., ChemDraw, MarvinSketch) and convert it to a 3D structure.
- **Energy Minimization:** Perform energy minimization of the 3D ligand structure using a suitable force field (e.g., MMFF94).
- **Add Hydrogens and Charges:** Add hydrogen atoms and compute partial charges for the ligand.
- **Define Torsion Tree:** Define the rotatable bonds in the ligand to allow for conformational flexibility during docking.
- **Save as PDBQT:** Save the prepared ligand structure in the PDBQT file format.

Grid Box Generation

- **Define the Binding Site:** Identify the active site of the protein, typically from the position of a co-crystallized ligand or from published literature.
- **Set Grid Parameters:** Define the dimensions and center of a 3D grid box that encompasses the entire binding site. The grid box should be large enough to allow the ligand to move and rotate freely.
- **Generate Grid Maps:** Use AutoGrid to pre-calculate the interaction energies for each atom type in the ligand with the protein at each grid point. This generates a set of grid map files.

Molecular Docking Simulation

- **Set Docking Parameters:** Configure the docking parameters in AutoDock. This includes specifying the ligand and receptor PDBQT files, the grid map files, and the search algorithm to be used (e.g., Lamarckian Genetic Algorithm).
- **Run Docking:** Execute the docking simulation. AutoDock will explore different conformations and orientations of the ligand within the grid box and calculate the corresponding binding

energies.

- **Analyze Results:** The output of the docking simulation is a set of docked conformations (poses) of the ligand, ranked by their predicted binding energies. Analyze the top-ranked poses to identify the most favorable binding mode and the key intermolecular interactions (e.g., hydrogen bonds, hydrophobic interactions) with the protein.

Visualization of Signaling Pathways and Workflows

Understanding the broader biological context of the protein target is crucial for drug development. The following diagrams, generated using the DOT language, visualize key signaling pathways and a typical in silico workflow.

Signaling Pathways

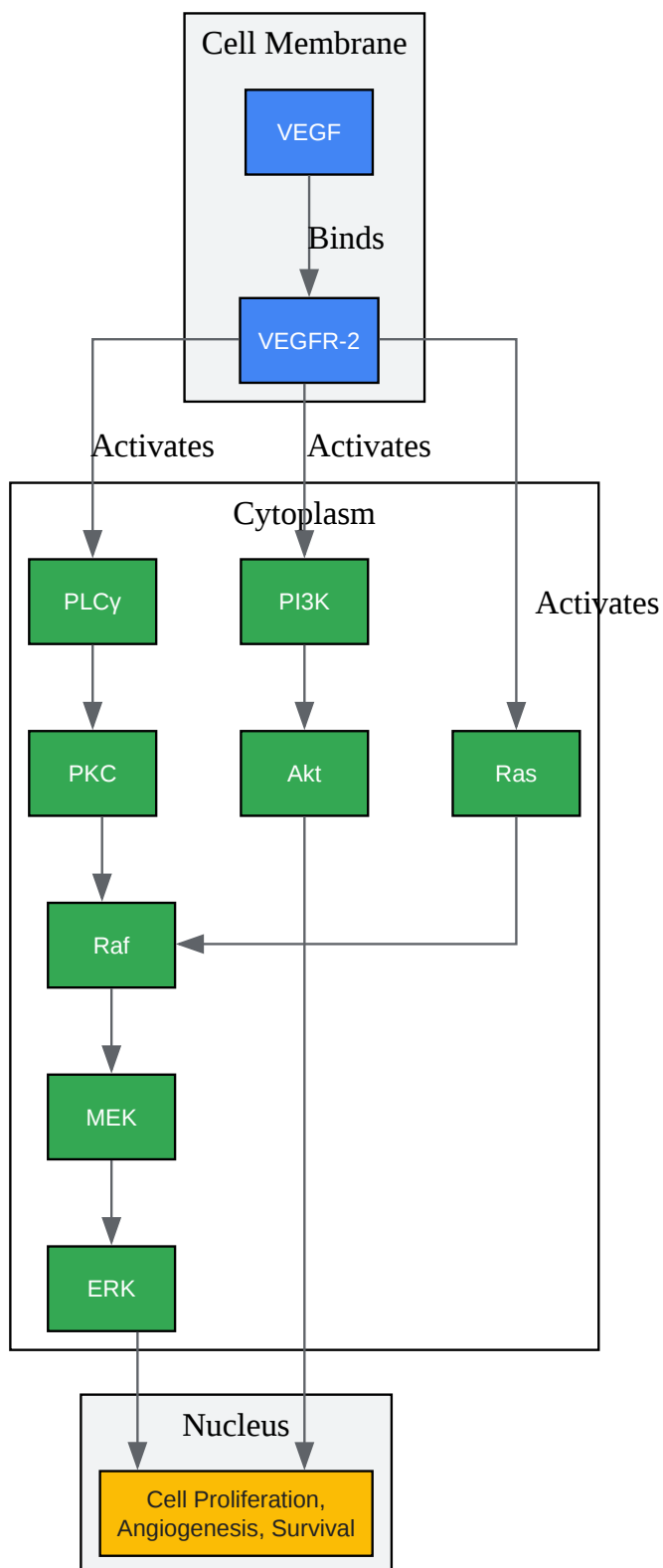

[Click to download full resolution via product page](#)

Caption: VEGFR-2 signaling pathway.

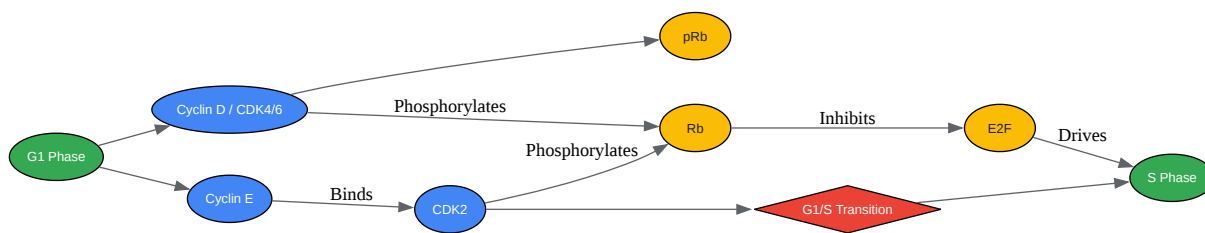

[Click to download full resolution via product page](#)

Caption: CDK2 in cell cycle regulation.

Experimental and Logical Workflows

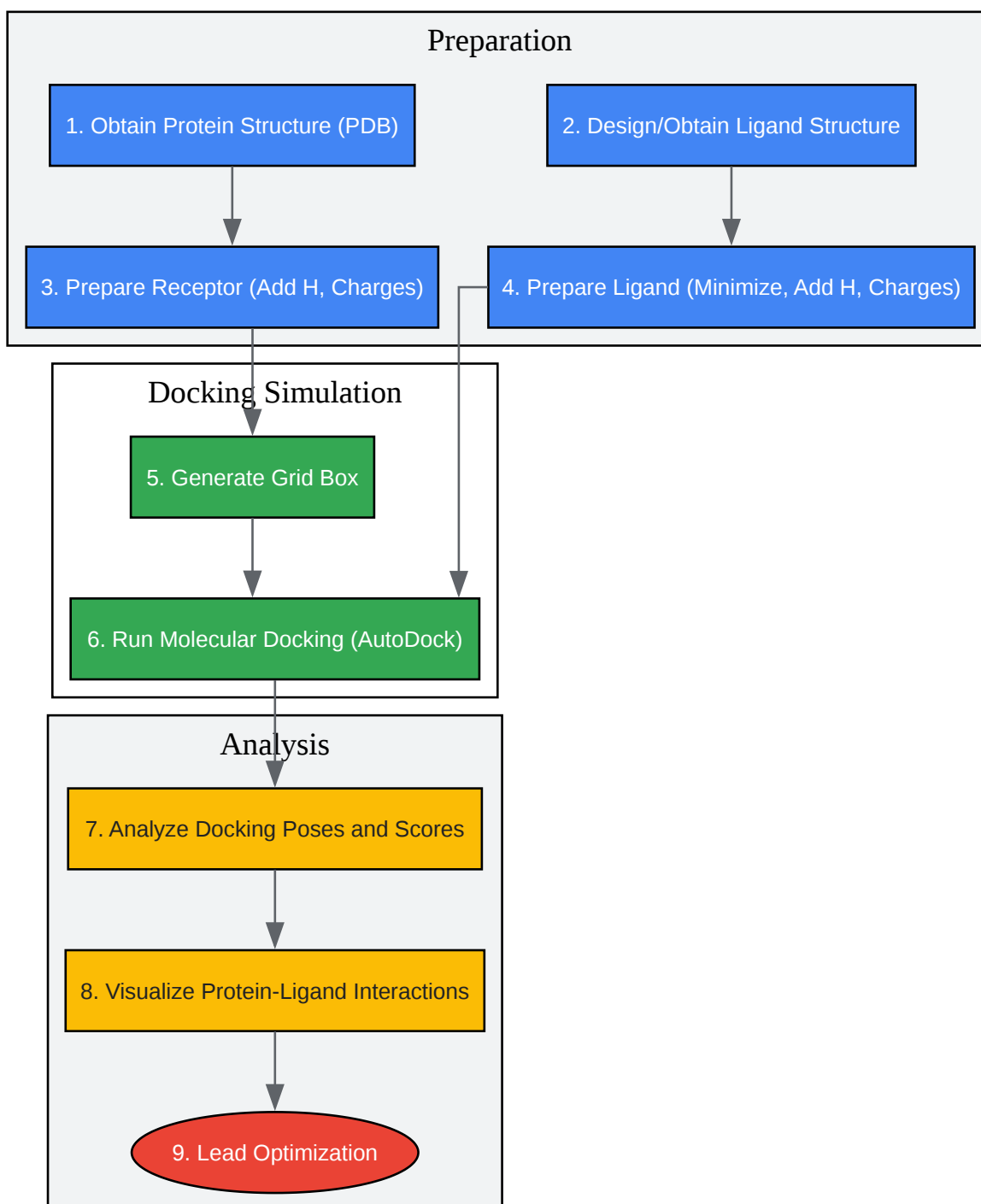

[Click to download full resolution via product page](#)

Need Custom Synthesis?

BenchChem offers custom synthesis for rare earth carbides and specific isotopic labeling.

Email: info@benchchem.com or [Request Quote Online](#).

References

- [1. mdpi.com \[mdpi.com\]](#)
- [2. RET signaling pathway and RET inhibitors in human cancer - PMC \[pmc.ncbi.nlm.nih.gov\]](#)
- [3. apexbt.com \[apexbt.com\]](#)
- [4. Cyclin-dependent kinase 2 - Wikipedia \[en.wikipedia.org\]](#)
- [5. RET tyrosine kinase signaling in development and cancer - PubMed \[pubmed.ncbi.nlm.nih.gov\]](#)
- [6. RET signaling pathway and RET inhibitors in human cancer - PubMed \[pubmed.ncbi.nlm.nih.gov\]](#)
- [7. Role and regulation of cyclooxygenase-2 during inflammation - PubMed \[pubmed.ncbi.nlm.nih.gov\]](#)
- [8. COX 2 pathway: Significance and symbolism \[wisdomlib.org\]](#)
- [9. 4-Hydroxyphenylpyruvate dioxygenase - PubMed \[pubmed.ncbi.nlm.nih.gov\]](#)
- [10. 4-Hydroxyphenylpyruvate dioxygenase - Wikipedia \[en.wikipedia.org\]](#)
- [11. apexbt.com \[apexbt.com\]](#)
- [12. 4-Hydroxyphenylpyruvate Dioxygenase Catalysis: IDENTIFICATION OF CATALYTIC RESIDUES AND PRODUCTION OF A HYDROXYLATED INTERMEDIATE SHARED WITH A STRUCTURALLY UNRELATED ENZYME - PMC \[pmc.ncbi.nlm.nih.gov\]](#)
- To cite this document: BenchChem. [In Silico Docking of Pyrazole-Based Inhibitors: A Technical Guide]. BenchChem, [2026]. [Online PDF]. Available at: [\[https://www.benchchem.com/product/b066816/docs#in-silico-docking-of-pyrazole-based-inhibitors-a-technical-guide\]](https://www.benchchem.com/product/b066816/docs#in-silico-docking-of-pyrazole-based-inhibitors-a-technical-guide)

Disclaimer & Data Validity:

The information provided in this document is for Research Use Only (RUO) and is strictly not intended for diagnostic or therapeutic procedures. While BenchChem strives to provide accurate protocols, we make no warranties, express or implied, regarding the fitness of this product for every specific experimental setup.

Technical Support: The protocols provided are for reference purposes. Unsure if this reagent suits your experiment?

Need Industrial/Bulk Grade? [Request Custom Synthesis Quote](#)

BenchChem

Our mission is to be the trusted global source of essential and advanced chemicals, empowering scientists and researchers to drive progress in science and industry.

Contact

Address: 3281 E Guasti Rd
Ontario, CA 91761, United States
Phone: (601) 213-4426
Email: info@benchchem.com

[Contact our Ph.D. Support Team for a compatibility check](#)