

# Technical Support Center: Moisture-Sensitive $^{13}\text{C}$ Anhydrides

**Author:** BenchChem Technical Support Team. **Date:** May 2026

## Compound of Interest

Compound Name: Acetic-2- $^{13}\text{C}$  acid, anhydride

CAS No.: 17830-01-2

Cat. No.: B6595059

[Get Quote](#)

## A Senior Application Scientist's Guide to Storage, Handling, and Troubleshooting

Welcome to the technical support center. As a Senior Application Scientist, I've seen brilliant experiments compromised by the subtlest of handling errors. Among the most sensitive reagents we encounter are isotopically labeled anhydrides, such as  $^{13}\text{C}$ -labeled acetic anhydride. Their high reactivity is a double-edged sword: excellent for acylation reactions but unforgiving when exposed to atmospheric moisture.[1][2] The financial and scientific investment in  $^{13}\text{C}$ -labeled compounds is significant; protecting that investment is paramount.[3]

This guide is structured to provide you with not just the "what" but the "why" behind best practices. We'll move from foundational knowledge in our FAQ section to practical, actionable solutions in our troubleshooting and protocol guides.

## Frequently Asked Questions (FAQs)

Q1: What are the ideal storage conditions for a new, unopened bottle of  $^{13}\text{C}$  anhydride?

An unopened bottle should be stored in a cool, dry, and well-ventilated area, away from incompatible materials like alcohols, amines, and strong bases.[4] The key is to prevent any possibility of moisture ingress. For long-term storage, maintaining a controlled, low-humidity environment is critical.[5][6] While room temperature is often acceptable for short periods, for hydrolytically labile compounds, storage at lower temperatures (-12°C to 4°C) under an inert atmosphere is best practice for maximizing shelf-life.[7][8]

| Parameter   | Recommendation   | Rationale   |
|-------------|--|---|
| Temperature | 2-8°C (Refrigerator) for long-term; Room Temperature for short-term.[7][8] | Reduces the rate of any potential degradation reactions.[9]   |
| Atmosphere  | Shipped under an inert atmosphere (Nitrogen or Argon).[10]                 | Prevents reaction with atmospheric oxygen and, more importantly, moisture.                          |
| Humidity    | Store in a desiccator or dry cabinet.[6][11]                               | Minimizes ambient moisture that could slowly permeate packaging over time.                          |
| Location    | A dedicated flammables cabinet.[12]  | Anhydrides are often flammable and should be segregated from oxidizers and ignition sources.[4][13] |

## Q2: Why is moisture such a critical issue for <sup>13</sup>C anhydrides?

The core issue is hydrolysis. Anhydrides react readily with water (H<sub>2</sub>O) to form two equivalents of the corresponding carboxylic acid.[14][15] When your anhydride is <sup>13</sup>C-labeled, this hydrolysis reaction irreversibly converts your valuable labeled reagent into a less reactive, and likely undesired, carboxylic acid byproduct.

This process directly impacts your experiment in three ways:

- **Reduced Reagent Purity:** The vial no longer contains pure anhydride.

- **Stoichiometric Errors:** You will be adding less of the active acylating agent than calculated, leading to lower reaction yields.
- **Isotopic Dilution:** The  $^{13}\text{C}$ -labeled carboxylic acid byproduct can contaminate your final product, complicating purification and analysis.

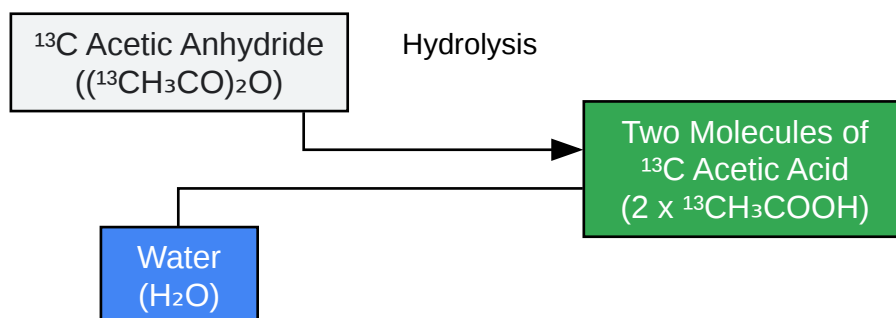

[Click to download full resolution via product page](#)

Caption: Hydrolysis of a  $^{13}\text{C}$  anhydride with water.

### Q3: How can I verify the integrity of my $^{13}\text{C}$ anhydride before use?

Trust, but verify. While a freshly opened bottle from a reputable supplier is generally reliable, it's a good practice to confirm its purity, especially if the bottle has been opened previously or stored for an extended period. The most direct method is  $^{13}\text{C}$  NMR spectroscopy.

A pure anhydride will show a characteristic carbonyl peak. The hydrolysis product, the carboxylic acid, will have a distinct carbonyl peak at a different chemical shift. By comparing the integration of these two peaks, you can determine the extent of degradation.

| Compound Type   | Typical $^{13}\text{C}$ Carbonyl Chemical Shift (ppm) |
|-----------------|---|
| Acid Anhydride  | 165 - 190 ppm   |
| Carboxylic Acid | 170 - 185 ppm   |

(Note: Exact shifts depend on the specific anhydride and solvent. The key is the presence of a second, distinct carbonyl peak.) [Source: 22, 38]

## Troubleshooting Guide

| Symptom   | Potential Cause  | Recommended Action & Explanation  |
|---|--|---|
| Low or no yield in my acylation reaction.                                     | Degraded $^{13}\text{C}$ Anhydride: The most common culprit. The anhydride has likely hydrolyzed, reducing the amount of active reagent available for your reaction.   | Verify Anhydride Purity: Run a quick $^{13}\text{C}$ NMR on an aliquot of the anhydride. If you observe a significant peak for the corresponding carboxylic acid, the reagent is compromised and should be discarded.[16]                             |
| My final product has a lower $^{13}\text{C}$ incorporation than expected.     | Partial Hydrolysis: You may have used a partially hydrolyzed anhydride. This introduces both the desired labeled acyl group and the unlabeled starting material (if the reaction is an auto-acylation) or other side products, effectively diluting your isotopic label. | Improve Handling Technique: Review your reagent transfer protocol. Ensure all glassware is rigorously dried and that you are using a proper inert atmosphere technique (see Protocol 2 below) to prevent moisture exposure during withdrawal.[17][18] |
| I see an unexpected, polar impurity in my LC-MS or TLC analysis.              | Carboxylic Acid Byproduct: The $^{13}\text{C}$ -labeled carboxylic acid formed from hydrolysis is more polar than the parent anhydride and will appear as a separate spot/peak.  | Confirm Impurity Identity: If possible, run a co-injection/co-spot with a standard of the expected carboxylic acid to confirm its identity. This validates that the issue stems from anhydride hydrolysis.  |
| The septum of my Sure/Seal™ bottle is difficult to pierce or appears cracked. | Septum Fatigue/Damage: Repeated punctures, especially with large-gauge needles, can compromise the septum's ability to reseal.[19] A damaged septum is a direct entry point for atmospheric moisture.  | Immediate Action: If the septum is visibly damaged, the reagent is at high risk. The best course of action is to transfer the remaining anhydride to a new, oven-dried, inert-gas-flushed vial with a fresh PTFE-lined septum inside a glovebox or    |

using Schlenk line techniques.

[20] For future use, always use the smallest gauge needle possible (e.g., 22-26 gauge) and pierce through the existing puncture hole when possible.

[19]

---

## Experimental Protocols

### Protocol 1: Initial Receipt and Storage of a New $^{13}\text{C}$ Anhydride Bottle

This protocol establishes a self-validating system from the moment the reagent enters your lab.

- **Inspect Packaging:** Upon receipt, check that the outer packaging and the manufacturer's seal on the bottle are intact. Any breach could indicate potential exposure.
- **Log Reagent:** Record the date of receipt, lot number, and intended first use date in your lab inventory.
- **Equilibrate (If Cold):** If the anhydride was shipped on ice, place the unopened bottle in a desiccator at room temperature for at least 2 hours before opening. This prevents condensation of atmospheric moisture on the cold bottle surface.
- **Initial Storage:** Store the unopened bottle in a designated, ventilated cabinet for flammable liquids, preferably within a secondary container.[12][21] For long-term storage (>1 month), place the bottle inside a desiccator cabinet that is periodically purged with dry nitrogen or argon.

### Protocol 2: Withdrawing a Liquid $^{13}\text{C}$ Anhydride Under Inert Atmosphere

This procedure is critical for preserving the reagent's integrity for multiple uses. The principle is to never allow moist lab air to enter the bottle. Any volume of liquid removed must be replaced by an equal volume of dry, inert gas.[10]

Preparation:

- Glassware & Syringe: Oven-dry all glassware (e.g., reaction flask) and the syringe/needle at 125°C for at least 4 hours.<sup>[17]</sup> Assemble the syringe while hot and allow it to cool to room temperature in a desiccator or under a stream of inert gas.
- Inert Gas Setup: Prepare a balloon or Schlenk line filled with dry nitrogen or argon.

Workflow:

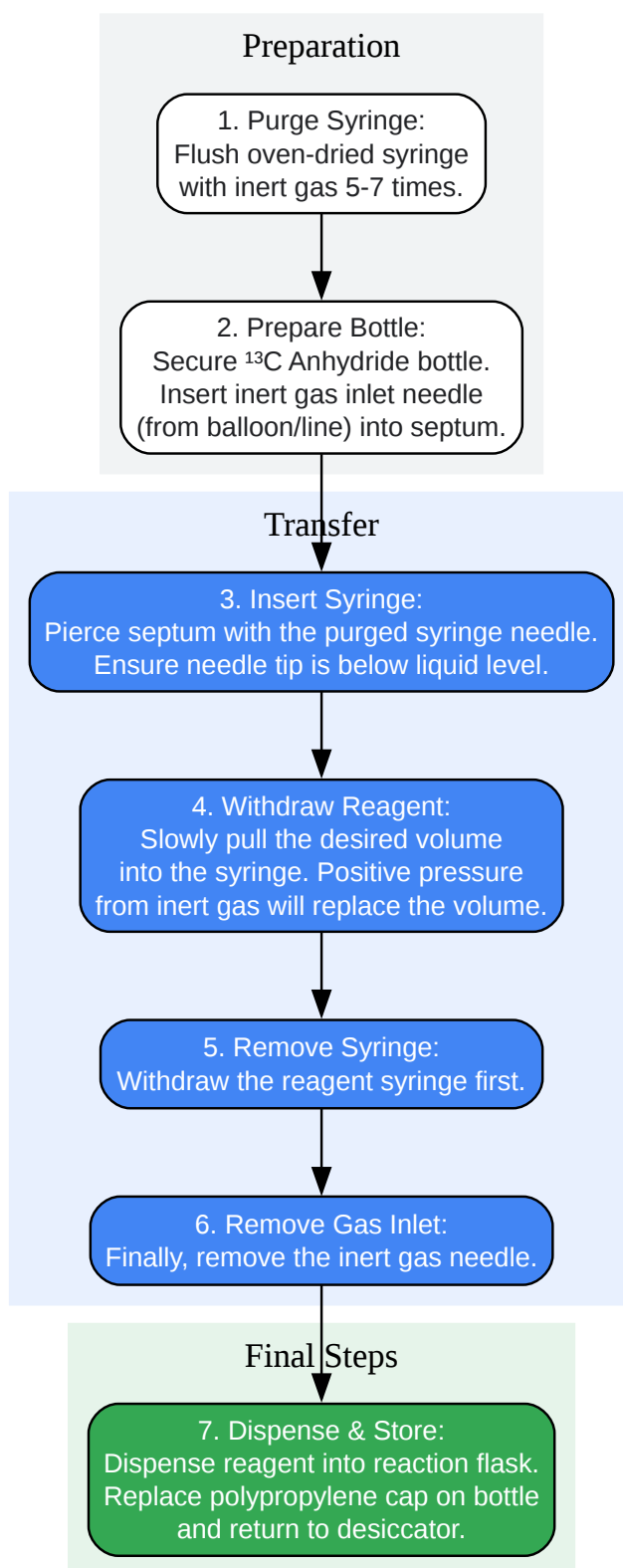

[Click to download full resolution via product page](#)

Caption: Workflow for withdrawing a moisture-sensitive reagent.

### Step-by-Step Methodology:

- **Purge the Syringe:** Draw inert gas into the dry syringe and expel it. Repeat this cycle 5-7 times to ensure the syringe is free of air.[19]
- **Establish Positive Pressure:** Gently insert a needle connected to your inert gas source through the bottle's septum. This needle should not be submerged in the liquid. You should see a gentle outflow of gas from the needle, confirming positive pressure.
- **Insert Transfer Syringe:** With the inert gas flowing, insert the needle of your purged syringe through the septum. The needle tip must be below the surface of the liquid anhydride.
- **Withdraw the Aliquot:** Slowly pull back the plunger to draw the desired volume. The inert gas from the balloon/line will automatically backfill the headspace, preventing a vacuum and ingress of air.[10]
- **Remove Needles:** First, remove the syringe containing your reagent. Then, remove the inert gas inlet needle.
- **Seal and Store:** Immediately replace the solid polypropylene cap over the Sure/Seal™ septum cap.[19] Return the bottle to its proper storage location (desiccator).
- **Dispense:** Promptly dispense the anhydride from the syringe into your reaction vessel, which should also be under an inert atmosphere.

By adhering to these principles and protocols, you can ensure the integrity of your valuable <sup>13</sup>C-labeled anhydrides, leading to more reliable, reproducible, and successful experimental outcomes.

## References

- INEOS Group. (2021, May 27).
- Echemi. (2022, May 20).
- New Jersey Department of Health. ACETIC ANHYDRIDE HAZARD SUMMARY.
- Sigma-Aldrich. (2025, September 23).
- VelocityEHS. (2024, January 30). SDS for Acetic Anhydride: A Guide to Chemical Safety.
- PEI-Genesis. A Practical Guide to MSL: Handling and Storing Sensitive Components.
- Chemistry Stack Exchange. (2023, November 4).

- PubMed.
- Mini-Circuits Blog. (2015, May 6). Handling Moisture Sensitive Devices.
- IsoLab, University of Washington.
- Wipf Group, University of Pittsburgh. (2014, February 22). Techniques for Handling Air- and Moisture-Sensitive Compounds.
- Sigma-Aldrich. Preservation of Moisture-Sensitive Chemical Reagents.
- Molecular Inorganic Chemistry, University of Helsinki. (2008, April 12). Working with air and moisture sensitive compounds.
- Sigma-Aldrich. Handling Air-Sensitive Reagents Technical Bulletin AL-134.
- Chemistry LibreTexts. (2022, May 6). 1.
- Cambridge Isotope Laboratories. Acetic anhydride-D<sub>6</sub> (D, 98%)
- Backens, S., et al. (2025). Analysis of the decomposition of an anhydride-cured epoxy resin by subcritical hydrolysis. Scientific Reports.
- Chemistry LibreTexts. (2023, January 29). Interpreting C-13 NMR Spectra.
- Chem-Matics (Chemistry+ Mathematics). (2021, August 22). Hydrolysis of Acetic anhydride|| Organic Chemistry. YouTube.
- Thermo Fisher Scientific.
- Hird, S. (2025, June 23).
- PubMed. Decomposition of malonic anhydrides.
- Alfa Chemistry. 13C Labeled Compounds.
- Oregon St

### Need Custom Synthesis?

BenchChem offers custom synthesis for rare earth carbides and specific isotopic labeling.

Email: [info@benchchem.com](mailto:info@benchchem.com) or [Request Quote Online](#).

## Sources

- 1. [echemi.com](https://www.echemi.com) [[echemi.com](https://www.echemi.com)]
- 2. [savemyexams.com](https://www.savemyexams.com) [[savemyexams.com](https://www.savemyexams.com)]
- 3. [isotope-science.alfa-chemistry.com](https://www.isotope-science.alfa-chemistry.com) [[isotope-science.alfa-chemistry.com](https://www.isotope-science.alfa-chemistry.com)]
- 4. [nj.gov](https://www.nj.gov) [[nj.gov](https://www.nj.gov)]
- 5. SDS for Acetic Anhydride: A Guide to Chemical Safety – KHA Online-SDS Management [[kha.com](https://www.kha.com)]

- [6. blog.minicircuits.com \[blog.minicircuits.com\]](https://blog.minicircuits.com)
- [7. Storage Stability Study of Salicylate-based Poly\(anhydride-esters\) - PubMed \[pubmed.ncbi.nlm.nih.gov\]](https://pubmed.ncbi.nlm.nih.gov)
- [8. isotope.com \[isotope.com\]](https://isotope.com)
- [9. Analysis of the decomposition of an anhydride-cured epoxy resin by subcritical hydrolysis - PubMed \[pubmed.ncbi.nlm.nih.gov\]](https://pubmed.ncbi.nlm.nih.gov)
- [10. Preservation of Moisture-Sensitive Chemical Reagents \[sigmaaldrich.com\]](https://sigmaaldrich.com)
- [11. electroniccomponent.com \[electroniccomponent.com\]](https://electroniccomponent.com)
- [12. IsoLab - Acetic Anhydride \[isolab.ess.washington.edu\]](https://isolab.ess.washington.edu)
- [13. sigmaaldrich.com \[sigmaaldrich.com\]](https://sigmaaldrich.com)
- [14. youtube.com \[youtube.com\]](https://youtube.com)
- [15. documents.thermofisher.com \[documents.thermofisher.com\]](https://documents.thermofisher.com)
- [16. Decomposition of malonic anhydrides - PubMed \[pubmed.ncbi.nlm.nih.gov\]](https://pubmed.ncbi.nlm.nih.gov)
- [17. ehs.umich.edu \[ehs.umich.edu\]](https://ehs.umich.edu)
- [18. chem.libretexts.org \[chem.libretexts.org\]](https://chem.libretexts.org)
- [19. ccc.chem.pitt.edu \[ccc.chem.pitt.edu\]](https://ccc.chem.pitt.edu)
- [20. molan.wdfiles.com \[moln.wdfiles.com\]](https://moln.wdfiles.com)
- [21. ineos.com \[ineos.com\]](https://ineos.com)
- To cite this document: BenchChem. [Technical Support Center: Moisture-Sensitive <sup>13</sup>C Anhydrides]. BenchChem, [2026]. [Online PDF]. Available at: [\[https://www.benchchem.com/product/b6595059/docs#technical-support-center-moisture-sensitive-c-anhydrides\]](https://www.benchchem.com/product/b6595059/docs#technical-support-center-moisture-sensitive-c-anhydrides)

---

### Disclaimer & Data Validity:

The information provided in this document is for Research Use Only (RUO) and is strictly not intended for diagnostic or therapeutic procedures. While BenchChem strives to provide accurate protocols, we make no warranties, express or implied, regarding the fitness of this product for every specific experimental setup.

**Technical Support:** The protocols provided are for reference purposes. Unsure if this reagent suits your experiment?

**Need Industrial/Bulk Grade?** [Request Custom Synthesis Quote](#)

## BenchChem

Our mission is to be the trusted global source of essential and advanced chemicals, empowering scientists and researchers to drive progress in science and industry.

### Contact

Address: 3281 E Guasti Rd  
Ontario, CA 91761, United States  
Phone: (601) 213-4426  
Email: [info@benchchem.com](mailto:info@benchchem.com)

[Contact our Ph.D. Support Team for a compatibility check](#)