

An In-Depth Technical Guide to Divinylbenzene's Interaction with Polymerization Initiators

Author: BenchChem Technical Support Team. **Date:** May 2026

Compound of Interest

Compound Name: *Divinylbenzene*

CAS No.: *91-14-5*

Cat. No.: *B6594060*

[Get Quote](#)

Introduction

Divinylbenzene (DVB) is a pivotal crosslinking agent in polymer science, prized for its ability to form rigid, insoluble, and thermally stable polymer networks.[1] Commercially available as a mixture of meta- and para-isomers, often with residual ethylvinylbenzene, DVB's dual vinyl functionality allows it to copolymerize with monovinyl monomers, such as styrene, to create three-dimensional polymer structures.[2] These crosslinked polymers are the backbone of essential materials like ion-exchange resins, chromatographic stationary phases, and supports for solid-phase synthesis in drug development.[1][3]

The transformation of liquid DVB monomers into a solid, crosslinked network is governed by the intricate interplay between the DVB molecules and the polymerization initiators. The choice of initiator is paramount as it dictates the polymerization mechanism, reaction kinetics, and ultimately, the morphology and properties of the final polymer. This guide provides a detailed exploration of the core principles governing the interaction of DVB with various classes of polymerization initiators, offering insights into the causality behind experimental choices and providing a framework for the rational design of DVB-based polymers.

Free-Radical Polymerization of Divinylbenzene

Free-radical polymerization is the most common method for preparing DVB-crosslinked polymers due to its tolerance to various functional groups and reaction conditions.[4] The process is initiated by the thermal or photochemical decomposition of a radical initiator to generate free radicals, which then react with DVB monomers to propagate the polymer chain.

Common Free-Radical Initiators

A variety of initiators can be employed for the free-radical polymerization of DVB, with the choice often depending on the desired polymerization temperature and the solvent system. The two most prevalent classes of thermal initiators are azo compounds and organic peroxides.

- **Azo Initiators:** Azobisisobutyronitrile (AIBN) and its derivatives are widely used due to their predictable first-order decomposition kinetics. The decomposition of AIBN is primarily influenced by temperature and is less susceptible to induced decomposition, leading to more controlled initiation rates.
- **Peroxide Initiators:** Benzoyl peroxide (BPO) is another common initiator. However, its decomposition can be more complex, with the potential for induced decomposition, where the initiator reacts with growing polymer radicals. This can lead to variations in the initiation rate and branching.

Mechanism of Interaction

The free-radical polymerization of DVB proceeds through the classical steps of initiation, propagation, crosslinking, and termination.

- **Initiation:** The process begins with the homolytic cleavage of the initiator (e.g., AIBN or BPO) to form two free radicals ($I\cdot$). This radical then adds to one of the vinyl groups of a DVB molecule, creating a new radical species.
- **Propagation:** The newly formed radical reacts with other DVB monomers, propagating the polymer chain. As DVB has two vinyl groups, the growing polymer chain will have pendant vinyl groups.

- **Crosslinking (Inter- and Intramolecular):** The pendant vinyl groups on the growing polymer chains can react with other growing chains (intermolecular crosslinking) or with a radical center on the same chain (intramolecular cyclization). Intermolecular crosslinking leads to the formation of a three-dimensional network and gelation. Intramolecular cyclization, on the other hand, results in the formation of cyclic structures within the polymer chain and does not contribute to network formation.
- **Termination:** The polymerization process is terminated by the combination or disproportionation of two growing polymer radicals.

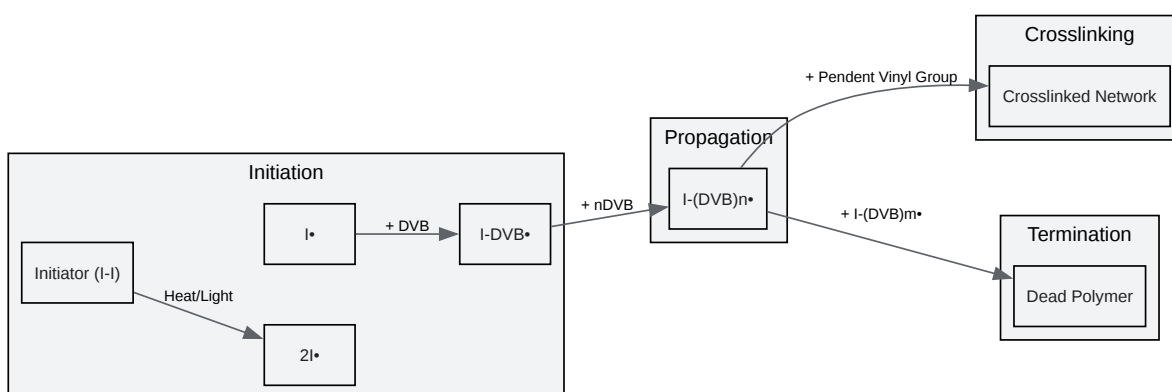

[Click to download full resolution via product page](#)

Caption: Free-Radical Polymerization of **Divinylbenzene**.

Experimental Protocol: Free-Radical Suspension Polymerization of DVB

This protocol describes a typical suspension polymerization of DVB to produce crosslinked polymer beads.

- **Aqueous Phase Preparation:** In a baffled reactor equipped with a mechanical stirrer, thermometer, and nitrogen inlet, dissolve a suspending agent (e.g., polyvinyl alcohol or

gelatin) in deionized water. The concentration of the suspending agent will influence the final particle size.

- **Organic Phase Preparation:** In a separate vessel, dissolve the initiator (e.g., AIBN or BPO) in the DVB monomer. If copolymerizing, add the comonomer (e.g., styrene) at this stage.
- **Dispersion:** With vigorous stirring, add the organic phase to the aqueous phase. The stirring speed is critical for controlling the droplet size, which in turn determines the final bead size.
- **Polymerization:** Heat the reactor to the desired temperature (typically 60-80 °C for AIBN or BPO) under a nitrogen atmosphere. Maintain the temperature and stirring for several hours until the polymerization is complete.
- **Work-up:** Cool the reactor and filter the polymer beads. Wash the beads thoroughly with hot water and then with a suitable organic solvent (e.g., methanol or acetone) to remove any unreacted monomer and initiator.
- **Drying:** Dry the polymer beads in a vacuum oven.

Quantitative Data: Initiator Effects

Initiator	Typical Temperature (°C)	Decomposition Half-life ($t_{1/2}$) at 70°C	Key Characteristics
AIBN	60 - 80	~5 hours	Predictable decomposition, less prone to side reactions.
BPO	70 - 90	~3 hours	Can undergo induced decomposition, potentially leading to broader molecular weight distribution.

Anionic Polymerization of Divinylbenzene

Anionic polymerization offers a pathway to more controlled polymer architectures, including linear polymers with pendant vinyl groups and block copolymers. This level of control is achieved through the use of highly reactive anionic initiators and stringent reaction conditions to prevent termination and chain transfer reactions.

Common Anionic Initiators

The most common initiators for the anionic polymerization of DVB are organolithium compounds.

- **Organolithium Reagents:** n-Butyllithium (n-BuLi) and sec-butyllithium (sec-BuLi) are frequently used. The choice between them can influence the initiation rate and the microstructure of the polymer.

Mechanism of Interaction

Anionic polymerization of DVB can proceed in a "living" manner, meaning that the propagating anionic centers remain active until they are intentionally terminated.

- **Initiation:** The polymerization is initiated by the nucleophilic attack of the organolithium initiator (e.g., n-BuLi) on one of the vinyl groups of DVB, forming a carbanion.
- **Propagation:** The carbanion then propagates by adding to other DVB monomers. A key feature of the anionic polymerization of DVB is the potential for selective polymerization of one vinyl group, leaving the other as a pendant reactive site. This is often achieved by conducting the polymerization at low temperatures and in the presence of specific additives.
- **Controlled Crosslinking:** The living nature of the polymerization allows for the controlled introduction of crosslinks. For instance, after the initial linear polymer is formed, a crosslinking agent can be added, or the temperature can be raised to promote the reaction of the pendant vinyl groups.

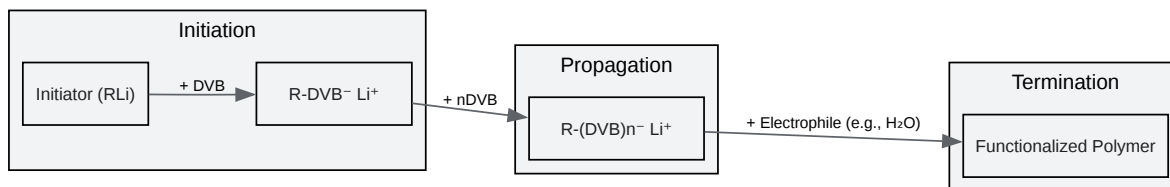

[Click to download full resolution via product page](#)

Caption: Anionic Polymerization of **Divinylbenzene**.

Experimental Protocol: Living Anionic Polymerization of DVB

This protocol requires rigorous anhydrous and anaerobic conditions.

- **Solvent and Monomer Purification:** Dry the solvent (e.g., tetrahydrofuran, THF) and the DVB monomer over a suitable drying agent (e.g., calcium hydride) and distill them under vacuum immediately before use.
- **Reactor Setup:** Assemble a glass reactor with a magnetic stirrer and a nitrogen/vacuum line. Flame-dry the reactor under vacuum and then fill it with dry, inert gas (e.g., argon or nitrogen).
- **Initiation:** Cool the reactor to a low temperature (e.g., -78 °C) and inject the purified solvent and DVB monomer. Then, add the organolithium initiator dropwise via a syringe. The appearance of a characteristic color (often red or orange) indicates the formation of the living anionic species.
- **Polymerization:** Allow the polymerization to proceed at the low temperature for the desired time. The molecular weight of the polymer can be controlled by the monomer-to-initiator ratio.
- **Termination:** Terminate the polymerization by adding a quenching agent, such as degassed methanol.

- Isolation: Precipitate the polymer by pouring the reaction mixture into a non-solvent (e.g., methanol). Filter and dry the polymer.

Cationic Polymerization of Divinylbenzene

Cationic polymerization of DVB is less common than free-radical or anionic methods but can be initiated by strong acids or Lewis acids. This method is particularly sensitive to impurities and requires careful control of reaction conditions.

Common Cationic Initiators

- Protic Acids: Strong acids like sulfuric acid (H_2SO_4) or perchloric acid (HClO_4) can initiate the polymerization of DVB.
- Lewis Acids: Lewis acids such as boron trifluoride (BF_3), aluminum chloride (AlCl_3), or titanium tetrachloride (TiCl_4) are often used in combination with a co-initiator like water or an alcohol. The Lewis acid and co-initiator form a complex that generates the initiating proton.

Mechanism of Interaction

The cationic polymerization of DVB proceeds via the formation of a carbocationic intermediate.

- Initiation: A proton from a protic acid or a Lewis acid/co-initiator complex adds to one of the vinyl groups of DVB, generating a carbocation.
- Propagation: The carbocation then reacts with other DVB monomers, propagating the polymer chain. Similar to anionic polymerization, there is the potential for the selective reaction of one vinyl group.
- Chain Transfer and Termination: Cationic polymerizations are often plagued by chain transfer reactions, where the growing carbocation transfers a proton to a monomer, solvent, or counter-ion, leading to the termination of one chain and the initiation of another. Termination can also occur by the combination of the propagating carbocation with the counter-ion.

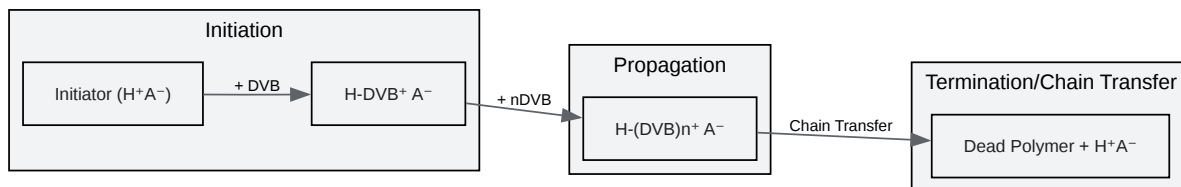

[Click to download full resolution via product page](#)

Caption: Cationic Polymerization of **Divinylbenzene**.

Comparative Analysis of Polymerization Methods

Feature	Free-Radical Polymerization	Anionic Polymerization	Cationic Polymerization
Initiators	Peroxides, Azo compounds	Organometallics (e.g., n-BuLi)	Protic acids, Lewis acids
Control over MW	Limited	High (living polymerization)	Moderate
Polydispersity	Broad	Narrow	Broad
Reaction Conditions	Less stringent	Requires high purity	Requires high purity
Side Reactions	Chain transfer, termination	Can be minimized	Frequent chain transfer
Polymer Architecture	Crosslinked networks	Linear, block, star polymers	Branched, crosslinked polymers
Industrial Viability	High	Moderate (specialty polymers)	Low

Conclusion

The interaction of **divinylbenzene** with polymerization initiators is a cornerstone of crosslinked polymer synthesis. The choice of initiator dictates the underlying polymerization mechanism—be it free-radical, anionic, or cationic—and consequently shapes the final properties of the

polymer network. Free-radical polymerization offers a robust and versatile method for producing highly crosslinked materials, while anionic polymerization provides a pathway to well-defined polymer architectures with controlled molecular weights and functionalities. Cationic polymerization, though less common, presents another avenue for DVB polymerization. A thorough understanding of these initiation mechanisms and their practical implications is essential for researchers and professionals in the field to rationally design and synthesize DVB-based polymers with tailored properties for a wide array of applications, from drug development to advanced materials.

References

- Rodrigo, R., Toro, C. A., & Cuellar, J. (2013). Morphological characteristics of poly (styrene-co-**divinylbenzene**)
- Storey, B. T. (1965). Copolymerization of styrene and p-**divinylbenzene**. Initial rates and gel points. *Journal of Polymer Science Part A: General Papers*, 3(1), 265-284.
- Okay, O., & Funke, W. (1990). Anionic dispersion polymerization of 1, 4-**divinylbenzene**. *Macromolecules*, 23(10), 2623-2628.
- Sato, T., et al. (2004).
- Taylor & Francis. (n.d.). **Divinylbenzene** – Knowledge and References. Retrieved from [[Link](#)]
- Wikipedia. (2023, October 27). **Divinylbenzene**. Retrieved from [[Link](#)]
- Odian, G. (2004).
- Hirao, A., et al. (2005). Living Anionic Polymerization of **Divinylbenzene** Derivatives. *Macromolecules*, 38(18), 7534-7542.
- Puskas, J. E., & Chen, Y. (2004). Biomedical application of commercial polymers and novel polyisobutylene-based thermoplastic elastomers for soft tissue replacement. *Biomacromolecules*, 5(4), 1141-1154.
- Toman, L., et al. (2003). Cationic copolymerization of isobutylene with **divinylbenzene**. *Polymer Bulletin*, 50(1-2), 1-8.
- Faust, R., & Kennedy, J. P. (1986). Living carbocationic polymerization. I.

Need Custom Synthesis?

BenchChem offers custom synthesis for rare earth carbides and specific isotopic labeling.

Email: info@benchchem.com or [Request Quote Online](#).

Sources

- [1. Experimental and theoretical investigations of divinylbenzene-based polymer as an efficient adsorbent for brilliant green dye removal - RSC Advances \(RSC Publishing\) \[pubs.rsc.org\]](#)
- [2. researchgate.net \[researchgate.net\]](#)
- [3. web.itu.edu.tr \[web.itu.edu.tr\]](#)
- [4. What is free radical polymerization? types, characteristics, reaction mechanism, and typical methods with examples | Information | FUJIFILM Wako Chemicals Europe GmbH \[specchem-wako.fujifilm.com\]](#)
- [To cite this document: BenchChem. \[An In-Depth Technical Guide to Divinylbenzene's Interaction with Polymerization Initiators\]. BenchChem, \[2026\]. \[Online PDF\]. Available at: \[https://www.benchchem.com/product/b6594060/docs#an-in-depth-technical-guide-to-divinylbenzene-s-interaction-with-polymerization-initiators\]](#)

Disclaimer & Data Validity:

The information provided in this document is for Research Use Only (RUO) and is strictly not intended for diagnostic or therapeutic procedures. While BenchChem strives to provide accurate protocols, we make no warranties, express or implied, regarding the fitness of this product for every specific experimental setup.

Technical Support: The protocols provided are for reference purposes. Unsure if this reagent suits your experiment?

Need Industrial/Bulk Grade? [Request Custom Synthesis Quote](#)

BenchChem

Our mission is to be the trusted global source of essential and advanced chemicals, empowering scientists and researchers to drive progress in science and industry.

Contact

Address: 3281 E Guasti Rd
Ontario, CA 91761, United States
Phone: (601) 213-4426
Email: info@benchchem.com

Contact our Ph.D. Support Team for a compatibility check