

# Technical Support Center: Optimizing $\text{Li}_4\text{Ti}_5\text{O}_{12}$ Anode Performance

**Author:** BenchChem Technical Support Team. **Date:** December 2025

## Compound of Interest

Compound Name: *Lithium titanate*

Cat. No.: *B6590807*

[Get Quote](#)

This technical support center provides researchers, scientists, and drug development professionals with troubleshooting guides and frequently asked questions (FAQs) to address common challenges encountered during the synthesis and electrochemical testing of  $\text{Li}_4\text{Ti}_5\text{O}_{12}$  (LTO) anodes, with a specific focus on reducing first cycle irreversible capacity loss.

## Troubleshooting Guides

This section provides solutions to specific issues that may arise during your experiments.

Issue 1: High First Cycle Irreversible Capacity Loss (>15%)

Potential Cause	Recommended Solution
Unstable Solid Electrolyte Interphase (SEI) Formation	Formation of a thick, unstable SEI consumes a significant amount of lithium ions during the first cycle. <a href="#">[1]</a> <a href="#">[2]</a> <a href="#">[3]</a> This is often exacerbated by reactions with residual water or impurities in the electrolyte.
<b>Solution 1: Electrochemical Pretreatment.</b> Before regular cycling, perform a slow formation cycle. For instance, discharge the cell to a lower potential (e.g., 0.01V) in the first cycle to form a more stable and uniform SEI layer, then operate within the normal voltage range (e.g., 1.0-2.5V) for subsequent cycles. <a href="#">[4]</a>	
<b>Solution 2: Use of Electrolyte Additives.</b> Incorporate additives like vinylene carbonate (VC) or fluoroethylene carbonate (FEC) into your electrolyte. These additives can help form a more stable and protective SEI layer on the LTO surface, reducing electrolyte decomposition. <a href="#">[4]</a>	
Surface Reactivity of LTO	The LTO surface can have catalytic activity that promotes electrolyte decomposition and gas evolution, contributing to irreversible capacity loss. <a href="#">[5]</a> <a href="#">[6]</a>
<b>Solution: Surface Coating.</b> Apply a conductive coating, such as carbon, to the LTO particles. This layer acts as a physical barrier, preventing direct contact between the LTO surface and the electrolyte, thus suppressing side reactions. <a href="#">[5]</a>	
Presence of Impurities	Impurity phases like anatase or rutile TiO <sub>2</sub> in the synthesized LTO can influence the reactivity with the electrolyte.
<b>Solution: Optimize Synthesis Conditions.</b> Carefully control the calcination temperature	

and duration during LTO synthesis to ensure phase purity. Characterize your material using X-ray diffraction (XRD) to confirm the absence of impurity peaks.

## Issue 2: Poor Rate Capability and High Polarization

Potential Cause	Recommended Solution
Low Electronic Conductivity of LTO	LTO is inherently a poor electronic conductor, which can limit its performance at high charge/discharge rates. <a href="#">[7]</a>
<p>Solution 1: Carbon Coating. A uniform carbon coating significantly enhances the electronic conductivity of the LTO particles.<a href="#">[7]</a><a href="#">[8]</a><a href="#">[9]</a></p>	
<p>Solution 2: Doping. Doping the LTO structure with cations (e.g., <math>\text{Nb}^{5+}</math>, <math>\text{Cr}^{3+}</math>, <math>\text{Mg}^{2+}</math>) or anions (e.g., <math>\text{F}^-</math>, <math>\text{Br}^-</math>) can increase electronic conductivity and lithium-ion diffusivity.<a href="#">[10]</a><a href="#">[11]</a></p>	
Poor Electrode Formulation	Inadequate mixing of the active material, conductive additive, and binder can lead to high internal resistance.
<p>Solution: Optimize Electrode Slurry Preparation. Ensure homogeneous mixing of all components. A common composition is 80-90% LTO, 5-10% conductive carbon (e.g., Super P), and 5-10% binder (e.g., PVDF) in an appropriate solvent like NMP.<a href="#">[12]</a></p>	

## Frequently Asked Questions (FAQs)

**Q1:** Is a Solid Electrolyte Interphase (SEI) expected to form on LTO anodes?

**A1:** While LTO operates at a higher potential (around 1.55 V vs.  $\text{Li}/\text{Li}^+$ ) than graphite, an SEI can and does form, particularly during the initial cycles. This SEI is influenced by the electrolyte

composition, the presence of additives, and the cycling conditions.[13] The formation of a stable and thin SEI is crucial for minimizing irreversible capacity loss.

Q2: What is the primary cause of gas generation in LTO-based cells?

A2: Gas generation, often observed as swelling in pouch cells, is primarily due to interfacial reactions between the LTO electrode surface and the electrolyte, especially at elevated temperatures.[5][6] The gases produced can include H<sub>2</sub>, CO<sub>2</sub>, and CO.[5]

Q3: How can I suppress this gas generation?

A3: Applying a uniform surface coating, such as amorphous carbon, is an effective strategy.[5] This coating acts as a barrier, preventing direct contact between the LTO and the electrolyte, thereby inhibiting the catalytic decomposition of the electrolyte and subsequent gas evolution.  
[5]

Q4: What are the benefits of carbon coating LTO?

A4: Carbon coating offers several advantages:

- **Improved Electronic Conductivity:** It significantly enhances the electrical conductivity of the LTO material.[7][8]
- **Reduced Irreversible Capacity:** It helps to form a more stable SEI and suppresses side reactions with the electrolyte.[5]
- **Suppressed Gas Generation:** It acts as a physical barrier to prevent electrolyte decomposition on the LTO surface.[5]
- **Enhanced Rate Capability:** The improved conductivity allows for faster charge and discharge rates.[7]

Q5: Can doping improve the performance of LTO?

A5: Yes, doping with various metal ions has been shown to improve the electrochemical performance of LTO. Doping can increase the electronic conductivity and/or the lithium-ion

diffusion coefficient, leading to better rate capability and potentially higher specific capacity.[10]  
[11]

## Quantitative Data Summary

The following tables summarize the impact of various modification strategies on the electrochemical performance of  $\text{Li}_4\text{Ti}_5\text{O}_{12}$ .

Table 1: Effect of Carbon Coating on LTO Performance

LTO Material	Coating Method	Carbon Source	Initial Discharge Capacity (0.1C)	Capacity Retention	Reference
Bare LTO	-	-	~160 mAh/g	~90% after 160 cycles (1C)	[14]
Carbon-Coated LTO	Post-coating	PVA	~170 mAh/g	-	[8]
Carbon-Coated LTO	Pyrolysis of Polyaniline	Polyaniline	165.38 mAh/g (0.5C)	93.51% after 150 cycles	[15]
Carbon-Coated LTO	Thermal Vapor Decomposition	-	-	Shows much better rate capability	[7]

Table 2: Effect of Doping on LTO Performance

Dopant	Doping Method	Discharge Capacity	Rate Capability	Reference
F <sup>-</sup>	Solid-state	165.38 mAh/g (0.5C)	-	[15]
I <sup>-</sup>	Solid-state	171.19 mAh/g (1C)	123.31 mAh/g at 15C	[11]
Cd <sup>2+</sup> and Ge <sup>4+</sup>	-	~169.1 mAh/g (0.1C)	98.79% retention after 300 cycles (2C)	[10]

Table 3: Effect of Electrolyte Additives on LTO Performance

Additive	Concentration	Effect on Performance	Reference
Vinylene Carbonate (VC)	-	Facilitates rapid formation of a protective SEI, improving rate and cyclic performance.	[13]
Fluoroethylene Carbonate (FEC)	-	Can improve cycle life and coulombic efficiency by reducing parasitic reactions.	[16]
Lithium Bis(trifluoromethanesulfonyl)imide (LiTFSI)	1.0 wt%	Can influence the composition of the surface film.	[17]
Lithium Bis(fluorosulfonyl)imide (LiFSI)	1.0 wt%	Affects the surface chemistry of the LTO electrode.	[17]

## Experimental Protocols

### 1. Synthesis of $\text{Li}_4\text{Ti}_5\text{O}_{12}$ via Sol-Gel Method

- Precursors: Tetrabutyl titanate  $[\text{Ti}(\text{OC}_4\text{H}_9)_4]$  as the titanium source and lithium acetate dihydrate ( $\text{CH}_3\text{COOLi}\cdot 2\text{H}_2\text{O}$ ) as the lithium source.
- Procedure:
  - Prepare the precursors at a Li:Ti molar ratio of 1:1 to compensate for potential lithium loss during calcination.
  - Age the resulting sol and then dry it at  $80^\circ\text{C}$  for 12 hours to form the precursor powder.
  - Calcine the precursor in a tube furnace at  $350^\circ\text{C}$  for 4 hours with a ramp rate of  $5^\circ\text{C}/\text{min}$ .
  - Follow with a second calcination step at  $800^\circ\text{C}$  for 12 hours in air to obtain the final LTO product.[\[18\]](#)

### 2. Carbon Coating of $\text{Li}_4\text{Ti}_5\text{O}_{12}$ using Polyaniline

- Materials: As-synthesized LTO powder, Polyaniline.
- Procedure:
  - Place the as-prepared LTO material in an alumina crucible.
  - Coat the LTO with carbon and nitrogen by the pyrolysis of Polyaniline at  $700^\circ\text{C}$  in an Argon gas tube furnace for 1 hour.[\[15\]](#)

### 3. Electrode Preparation

- Composition: 80-90% LTO active material, 5-10% conductive carbon (e.g., Super P or C65), and 5-10% polyvinylidene fluoride (PVDF) binder by weight.
- Procedure:
  - Blend the components in N-methyl-2-pyrrolidone (NMP) solvent to form a homogeneous slurry.

- Cast the slurry onto a current collector (e.g., copper foil) using a doctor blade.
- Dry the coated foil in a vacuum oven at an appropriate temperature (e.g., 80-120°C) for several hours to remove the solvent.
- Punch out circular electrodes of the desired size for cell assembly.[\[12\]](#)[\[18\]](#)[\[19\]](#)

#### 4. Coin Cell Assembly and Testing

- Components: LTO working electrode, lithium metal counter/reference electrode, separator (e.g., Celgard), and electrolyte (e.g., 1M LiPF<sub>6</sub> in a mixture of ethylene carbonate and dimethyl carbonate).
- Assembly: Assemble the components in an argon-filled glovebox to prevent moisture contamination.
- Testing:
  - Perform galvanostatic charge-discharge cycling within a specific voltage window (e.g., 1.0-2.5 V vs. Li/Li<sup>+</sup>).
  - Conduct cyclic voltammetry (CV) to study the redox behavior.
  - Use electrochemical impedance spectroscopy (EIS) to analyze the internal resistance and charge transfer kinetics.[\[19\]](#)

## Visualizations



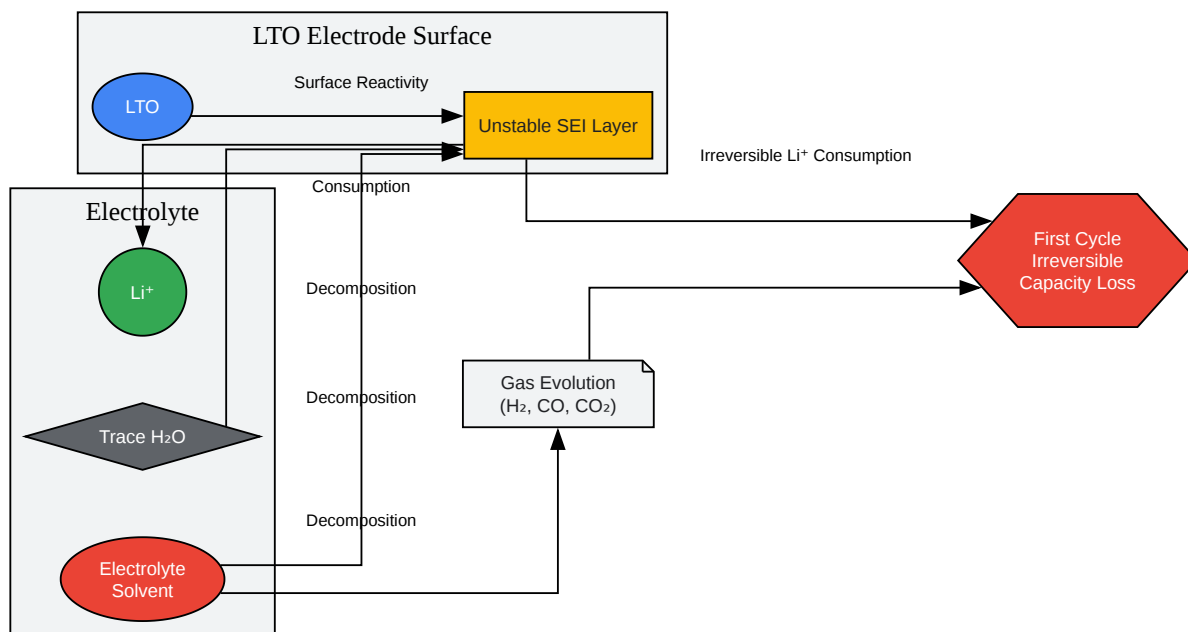

[Click to download full resolution via product page](#)

Caption: Mechanism of first cycle irreversible capacity loss in LTO anodes.

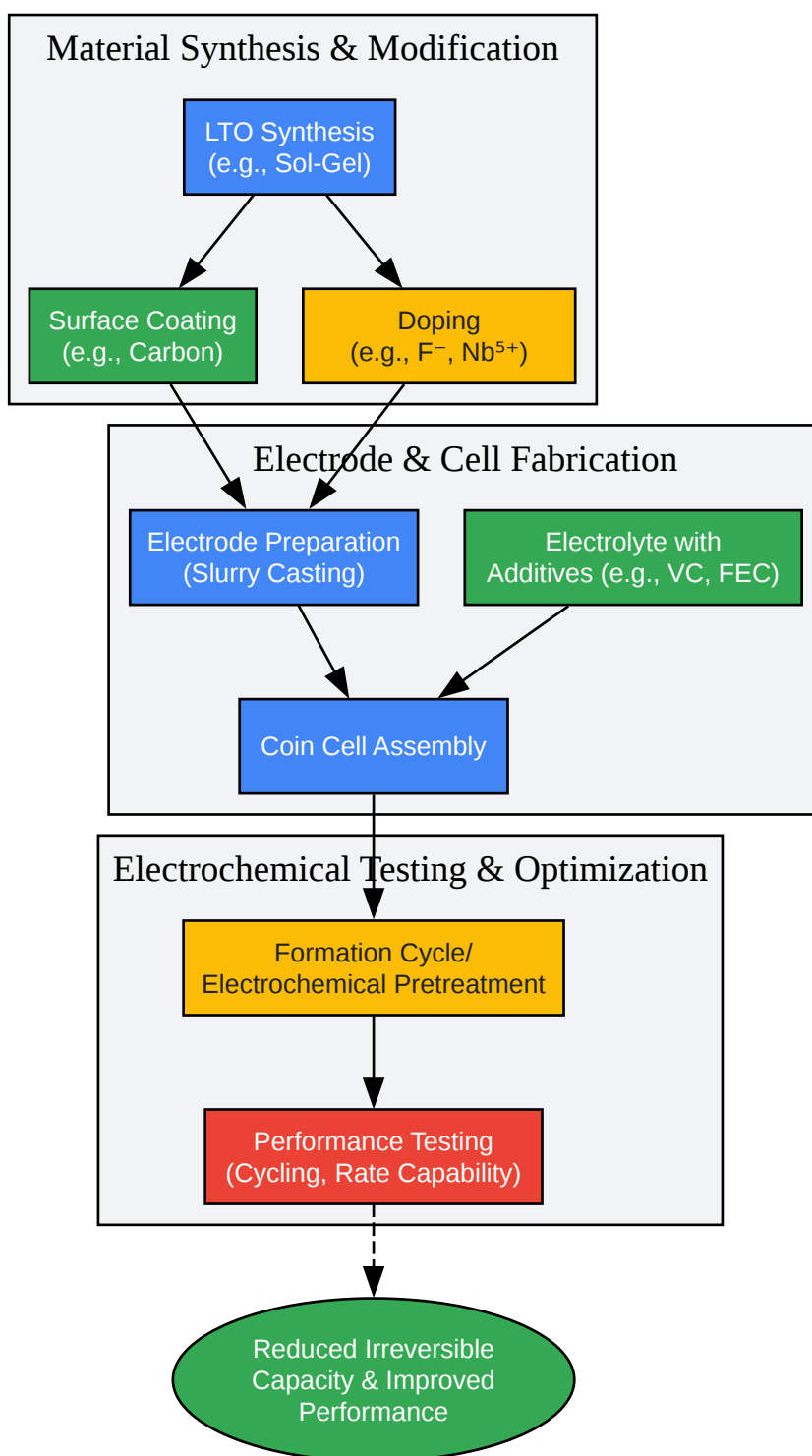

[Click to download full resolution via product page](#)

Caption: Workflow for mitigating irreversible capacity loss in LTO anodes.

### Need Custom Synthesis?

BenchChem offers custom synthesis for rare earth carbides and specific isotopic labeling.

Email: [info@benchchem.com](mailto:info@benchchem.com) or [Request Quote Online](#).

## References

- 1. Capacity Fade Mechanism of Li<sub>4</sub>Ti<sub>5</sub>O<sub>12</sub> Nanosheet Anode: Abstract, Citation (BibTeX) & Reference | Bohrium [bohrium.com]
- 2. web.mit.edu [web.mit.edu]
- 3. Capacity Loss Mechanism of the Li<sub>4</sub>Ti<sub>5</sub>O<sub>12</sub> Microsphere Anode of Lithium-Ion Batteries at High Temperature and Rate Cycling Conditions - PubMed [pubmed.ncbi.nlm.nih.gov]
- 4. researchgate.net [researchgate.net]
- 5. researchgate.net [researchgate.net]
- 6. researchgate.net [researchgate.net]
- 7. nanogroup.fudan.edu.cn [nanogroup.fudan.edu.cn]
- 8. electrochemsci.org [electrochemsci.org]
- 9. researchgate.net [researchgate.net]
- 10. researchgate.net [researchgate.net]
- 11. mdpi.com [mdpi.com]
- 12. researchgate.net [researchgate.net]
- 13. researchgate.net [researchgate.net]
- 14. researchgate.net [researchgate.net]
- 15. mdpi.com [mdpi.com]
- 16. docs.nrel.gov [docs.nrel.gov]
- 17. researchgate.net [researchgate.net]
- 18. mdpi.com [mdpi.com]
- 19. Designing Spinel Li<sub>4</sub>Ti<sub>5</sub>O<sub>12</sub> Electrode as Anode Material for Poly(ethylene)oxide-Based Solid-State Batteries - PMC [pmc.ncbi.nlm.nih.gov]

- To cite this document: BenchChem. [Technical Support Center: Optimizing Li<sub>4</sub>Ti<sub>5</sub>O<sub>12</sub> Anode Performance]. BenchChem, [2025]. [Online PDF]. Available at: [https://www.benchchem.com/product/b6590807#reducing-first-cycle-irreversible-capacity-of-li4ti5o12]

---

### Disclaimer & Data Validity:

The information provided in this document is for Research Use Only (RUO) and is strictly not intended for diagnostic or therapeutic procedures. While BenchChem strives to provide accurate protocols, we make no warranties, express or implied, regarding the fitness of this product for every specific experimental setup.

**Technical Support:** The protocols provided are for reference purposes. Unsure if this reagent suits your experiment? [[Contact our Ph.D. Support Team for a compatibility check](#)]

**Need Industrial/Bulk Grade?** [Request Custom Synthesis Quote](#)

## BenchChem

Our mission is to be the trusted global source of essential and advanced chemicals, empowering scientists and researchers to drive progress in science and industry.

### Contact

Address: 3281 E Guasti Rd

Ontario, CA 91761, United States

Phone: (601) 213-4426

Email: [info@benchchem.com](mailto:info@benchchem.com)