

Strategic HPLC Method Development for 2,2-Dimethyl-4-methylideneoxane

Author: BenchChem Technical Support Team. **Date:** May 2026

Compound of Interest

Compound Name: 2,2-dimethyl-4-methylideneoxane

CAS No.: 62913-30-8

Cat. No.: B6589184

[Get Quote](#)

A Comparative Guide for Process Monitoring and Purity Analysis

Executive Summary & Molecule Profile

2,2-dimethyl-4-methylideneoxane (structurally related to substituted tetrahydropyrans and often confused with the dioxolane analog) presents a classic analytical paradox: it is a volatile, hydrophobic cyclic ether with a "stealth" chromophore.

While Gas Chromatography (GC-FID) is the traditional gold standard for such volatile ethers, it fails during in-process monitoring of aqueous reaction mixtures (e.g., Prins cyclization or acid-catalyzed rearrangements) due to matrix incompatibility. This guide outlines the development of a robust Reverse-Phase HPLC (RP-HPLC) method designed specifically to bridge that gap, comparing its performance against GC-FID and Refractive Index (RI) detection.

Physicochemical Constraints

Property	Value / Characteristic	Analytical Implication
Structure	Cyclic ether with exocyclic alkene	Acid Labile: Avoid pH < 3.0 to prevent hydration of the double bond.
Chromophore	Isolated C=C (Exocyclic)	UV Weakness: Absorbance max is <200 nm. Detection requires = 205 nm.[1]
LogP	~2.5 - 3.0 (Estimated)	Hydrophobic: Strong retention on C18; requires high % organic modifier.
Volatility	Boiling Point ~120–130°C	Risk: Sample evaporation in autosampler; GC is viable for isolated product.

Method Selection: The Decision Matrix

The choice between HPLC and GC is not binary; it depends on the sample state.[2][3] The following decision tree illustrates when to deploy the HPLC method described in this guide versus the GC alternative.

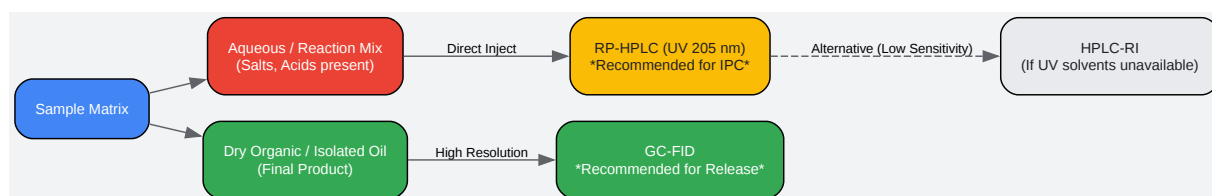

[Click to download full resolution via product page](#)

Figure 1: Analytical decision matrix. HPLC is essential for wet reaction streams where GC injection liners would degrade.

Comparative Analysis: HPLC-UV vs. HPLC-RI vs. GC-FID

The following data summarizes the performance characteristics of the three primary approaches.

Performance Benchmark Table

Parameter	Method A: RP-HPLC (UV 205 nm)	Method B: RP-HPLC (RI)	Method C: GC-FID
Primary Use Case	In-Process Control (IPC) of aqueous layers.	Polymer/Excipient analysis; High conc. assay.	Final Purity Release; Residual Solvents.
LOD (Limit of Detection)	~0.5 µg/mL (Moderate)	~50 µg/mL (Poor)	<0.05 µg/mL (Excellent)
Linearity ()	> 0.999 (0.1–100 µg/mL)	> 0.995 (100–1000 µg/mL)	> 0.9999 (Trace levels)
Selectivity	Moderate (Solvent peaks interfere).	Low (Universal detection).	High (Thermal separation).
Robustness	Low: Sensitive to solvent quality (UV cutoff).	High: Temperature dependent only.	High: Standard FID stability.
Gradient Capability	Yes (With baseline drift correction).	No (Isocratic only).	Yes (Temperature ramp).

Detailed Experimental Protocol: RP-HPLC-UV (Method A)

This protocol is optimized for the detection of the isolated double bond at 205 nm. Note: Standard HPLC-grade Methanol cannot be used here due to its UV cutoff at ~205 nm, which would blind the detector.

Chromatographic Conditions[1][2][3][4][5][6][7]

- System: Agilent 1290 Infinity II or Waters Alliance (Low dwell volume preferred).
- Column: Agilent Zorbax Eclipse Plus C18 (100 mm x 4.6 mm, 3.5 μ m) or equivalent.
 - Why? A shorter column with 3.5 μ m particles balances resolution with backpressure, allowing faster flow rates to minimize on-column diffusion of this volatile analyte.
- Mobile Phase A: Milli-Q Water (0.1% Phosphoric Acid or Neutral).
 - Note: Use Phosphoric acid only if the molecule is stable; otherwise, use neutral water. Avoid Acetate/Formate buffers (high UV absorbance).
- Mobile Phase B: Acetonitrile (HPLC Far UV Grade or LC-MS Grade).
 - Critical: Acetonitrile has a UV cutoff of 190 nm, permitting detection at 205 nm.[1]
- Flow Rate: 1.0 mL/min.
- Column Temp: 30°C.
- Detection: DAD/VWD @ 205 nm (Bandwidth 4 nm, Ref 360 nm).
- Injection Volume: 5–10 μ L.

Gradient Program

The molecule is hydrophobic. A steep gradient is required to elute it sharply.

Time (min)	% Mobile Phase B (ACN)	Event
0.0	40	Initial Hold
8.0	90	Elution of 2,2-dimethyl-4-methylideneoxane
10.0	90	Wash
10.1	40	Re-equilibration
14.0	40	End

Workflow Diagram

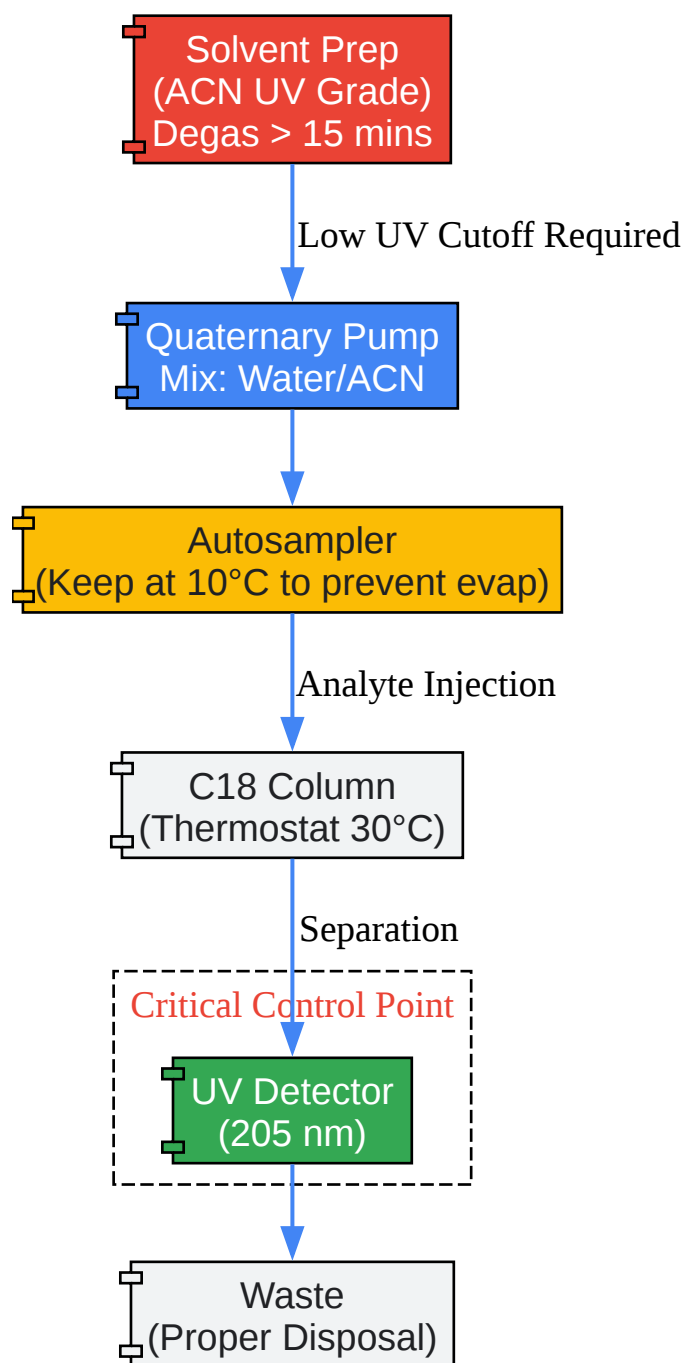

[Click to download full resolution via product page](#)

Figure 2: HPLC flow path emphasizing solvent quality and temperature control to mitigate volatility.

Expert Insights & Troubleshooting (E-E-A-T)

As a Senior Scientist, I have encountered specific failure modes with this class of compounds. Here is the causality and the fix:

The "Drifting Baseline" at 205 nm

- Observation: During the gradient (40% -> 90% ACN), the baseline rises significantly, masking the analyte peak.
- Causality: The refractive index change and trace impurities in the "A" solvent (Water) absorb at 205 nm.
- Fix: Use a "Ghost Trap" column between the pump and injector to strip organic impurities from the aqueous line. Ensure the reference wavelength is off or set to 360 nm to avoid over-compensation.

Peak Tailing

- Observation: The exocyclic double bond can interact with free silanols on the silica support.
- Causality: Secondary interactions.
- Fix: Use an "End-capped" column (e.g., Eclipse Plus or Symmetry Shield). If pH stability permits, adding 10mM Ammonium Bicarbonate (pH 7.8) often sharpens peaks for cyclic ethers better than acidic mobile phases.

Sample Disappearance

- Observation: Area counts decrease over a sequence.
- Causality: Volatility of **2,2-dimethyl-4-methylideneoxane**.
- Fix: Set autosampler temperature to 4°C–10°C. Use septum caps with a PTFE liner and ensure they are pre-slit to prevent vacuum formation, but tight enough to stop evaporation.

References

- Shinde, V. (2020). Analytical Method Development Approach When Compounds Don't Have UV Chromophore. Veeprho. [Link](#)

- Chromatography Online. (2018). UV Detection for HPLC – Fundamental Principle, Practical Implications. LCGC. [Link](#)
- Phenomenex. (2025). HPLC vs GC: What Sets These Methods Apart. Phenomenex Blog. [Link](#)
- PubChem. (2025).[4] 2,2-Dimethyl-4-methylidene-1,3-dioxolane Compound Summary. National Library of Medicine. [Link](#)
- Knauer. (n.d.). What UV wavelength is appropriate for my HPLC application? (UV Cutoff Data). Knauer FAQs. [Link](#)

Need Custom Synthesis?

BenchChem offers custom synthesis for rare earth carbides and specific isotopic labeling.

Email: info@benchchem.com or [Request Quote Online](#).

Sources

- 1. uv detection at 205 nm - Chromatography Forum [chromforum.org]
- 2. drawellanalytical.com [drawellanalytical.com]
- 3. veeprho.com [veeprho.com]
- 4. 4-Methylen-2,2-dimethyl-1,3-dioxolane | C₆H₁₀O₂ | CID 12409146 - PubChem [pubchem.ncbi.nlm.nih.gov]
- To cite this document: BenchChem. [Strategic HPLC Method Development for 2,2-Dimethyl-4-methylideneoxane]. BenchChem, [2026]. [Online PDF]. Available at: [<https://www.benchchem.com/product/b6589184/docs#strategic-hplc-method-development-for-2-2-dimethyl-4-methylideneoxane>]

Disclaimer & Data Validity:

The information provided in this document is for Research Use Only (RUO) and is strictly not intended for diagnostic or therapeutic procedures. While BenchChem strives to provide accurate protocols, we make no warranties, express or implied, regarding the fitness of this product for every specific experimental setup.

Technical Support: The protocols provided are for reference purposes. Unsure if this reagent suits your experiment?

Need Industrial/Bulk Grade? [Request Custom Synthesis Quote](#)

BenchChem

Our mission is to be the trusted global source of essential and advanced chemicals, empowering scientists and researchers to drive progress in science and industry.

Contact

Address: 3281 E Guasti Rd
Ontario, CA 91761, United States
Phone: (601) 213-4426
Email: info@benchchem.com

[Contact our Ph.D. Support Team for a compatibility check](#)