

Application Notes & Protocols: Epoxidation of Alkenes Using 2,2,2-Trifluoroacetophenone

Author: BenchChem Technical Support Team. **Date:** May 2026

Compound of Interest

Compound Name: *2',5'-Dimethyl-2,2,2-trifluoroacetophenone*

CAS No.: 181828-02-4

Cat. No.: B065298

[Get Quote](#)

Introduction: The Advance of Organocatalytic Epoxidation

The epoxidation of alkenes is a cornerstone transformation in organic synthesis, providing versatile epoxide intermediates crucial for the production of pharmaceuticals, agrochemicals, and fine chemicals.^[1] Historically, this reaction has been dominated by stoichiometric reagents like meta-chloroperoxybenzoic acid (mCPBA) or metal-based catalytic systems.^{[1][2]} While effective, these methods often present challenges related to hazardous byproducts, metal contamination, and cost.

The advent of organocatalysis has ushered in a new era of safer, more sustainable chemical synthesis.^[1] Within this field, ketone-catalyzed epoxidation has emerged as a powerful, metal-free alternative.^[3] The mechanism relies on the in situ generation of a highly reactive dioxirane species from a ketone and a terminal oxidant, such as potassium peroxymonosulfate (Oxone) or hydrogen peroxide (H₂O₂).^{[3][4][5]}

This application note focuses on the use of 2,2,2-trifluoroacetophenone as a highly efficient organocatalyst for alkene epoxidation. The strong electron-withdrawing nature of the trifluoromethyl group significantly activates the ketone carbonyl, facilitating the formation of the dioxirane intermediate and enabling high catalytic turnover.^[5] We present a cheap, mild, fast, and environmentally friendly protocol using H₂O₂ as the terminal oxidant, which offers substantial improvements over previous methods by utilizing low catalyst loadings (2–5 mol%) and achieving high to quantitative yields in short reaction times.^{[1][6][7]}

The Catalytic Mechanism: Activating Hydrogen Peroxide

The efficacy of the 2,2,2-trifluoroacetophenone catalyst hinges on its ability to activate hydrogen peroxide, which is otherwise a poor oxidant for this transformation.^[1] The catalytic cycle, as elucidated in mechanistic studies, proceeds through the formation of a potent dioxirane intermediate.

- **Initial Activation:** In the presence of an aqueous basic buffer and acetonitrile, hydrogen peroxide reacts to form a peroxy-carboximidic acid intermediate.^[6]
- **Dioxirane Formation:** This intermediate, or H₂O₂ itself, performs a nucleophilic attack on the highly electrophilic carbonyl carbon of the 2,2,2-trifluoroacetophenone catalyst. The catalyst's hydrated form is believed to be the active species.^[6] Subsequent intramolecular cyclization, with the loss of a water molecule, generates the key dioxirane intermediate.
- **Oxygen Transfer:** The strained three-membered ring of the dioxirane is a powerful oxygen-atom donor. It reacts with the electron-rich double bond of the alkene substrate in a concerted, stereospecific syn-addition to form the desired epoxide.^[2]
- **Catalyst Regeneration:** Upon transferring the oxygen atom, the dioxirane collapses, regenerating the 2,2,2-trifluoroacetophenone catalyst, which can then re-enter the catalytic cycle.

This efficient cycle allows for the use of substoichiometric amounts of the ketone catalyst.^{[1][8]}

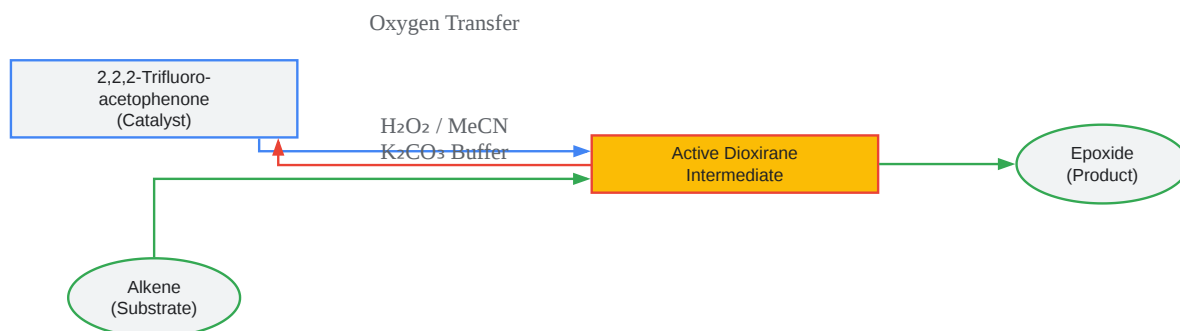

[Click to download full resolution via product page](#)

Figure 1: Catalytic cycle for the epoxidation of alkenes.

Experimental Protocol: General Procedure

This protocol is adapted from the optimized conditions reported by Limnios and Kokotos (2014).^{[1][6]} It is designed to be robust for a wide range of olefin substrates.

Materials and Reagents

- Catalyst: 2,2,2-Trifluoroacetophenone (≥98%)
- Substrate: Alkene (1.00 mmol scale)
- Oxidant: 30% Aqueous Hydrogen Peroxide (H₂O₂)
- Solvents: tert-Butyl alcohol (t-BuOH), Acetonitrile (MeCN)
- Buffer Solution: 0.6 M Potassium Carbonate (K₂CO₃) with 4 x 10⁻⁵ M EDTA tetrasodium salt in deionized water.
 - Scientist's Note: The basic buffer (pH ≈ 11) is crucial for activating the hydrogen peroxide and preventing acid-catalyzed ring-opening of the epoxide product.^{[1][4]} EDTA is a metal

scavenger that prevents decomposition of H_2O_2 by trace metal impurities.

- Purification: Silica gel for flash column chromatography, petroleum ether, diethyl ether (Et_2O), ethyl acetate (EtOAc).

Equipment

- Round-bottom flask with a magnetic stir bar
- Standard laboratory glassware
- Magnetic stir plate
- Flash chromatography setup
- Rotary evaporator

Step-by-Step Protocol

- Reaction Setup: In a round-bottom flask, place the alkene (1.00 mmol, 1.0 equiv).
- Catalyst Addition: Add 2,2,2-trifluoroacetophenone (9.0 mg, 0.05 mmol, 0.05 equiv).
- Solvent Addition: Consecutively add the following solvents and reagents under ambient atmosphere:
 - tert-Butyl alcohol (1.5 mL)
 - Aqueous buffer solution (1.5 mL)
 - Acetonitrile (0.11 mL, 2.00 mmol, 2.0 equiv)
- Oxidant Addition: Carefully add 30% aqueous H_2O_2 (0.23 mL, 2.00 mmol, 2.0 equiv).
 - Safety Note: Hydrogen peroxide is a strong oxidant. Always wear appropriate personal protective equipment (PPE), including safety glasses and gloves.
- Reaction Execution: Allow the biphasic mixture to stir vigorously at room temperature for 1 hour. Reaction progress can be monitored by Thin Layer Chromatography (TLC) or Gas

Chromatography (GC).

- Work-up:
 - Upon completion, dilute the reaction mixture with water (5 mL) and diethyl ether (10 mL).
 - Separate the organic layer.
 - Extract the aqueous layer twice more with diethyl ether (2 x 10 mL).
 - Combine the organic layers, wash with brine (15 mL), and dry over anhydrous sodium sulfate (Na_2SO_4).
- Purification:
 - Filter off the drying agent and concentrate the solution in vacuo using a rotary evaporator.
 - Purify the crude product residue by flash column chromatography on silica gel, typically using mixtures of petroleum ether/diethyl ether or petroleum ether/ethyl acetate to afford the pure epoxide.[1]

Figure 2: Step-by-step experimental workflow for epoxidation.

Substrate Scope and Performance

This catalytic system demonstrates broad applicability across various classes of alkenes. High to quantitative yields are typically achieved for mono-, di-, and trisubstituted olefins.[6][7] The chemoselectivity is excellent, with the reaction tolerating other potentially oxidizable functional groups.

Entry	Alkene Substrate	Catalyst Loading (mol%)	Time (h)	Yield (%)
1	1-Phenylcyclohexene	5	1	96
2	(E)-Stilbene	5	1	99
3	Cyclooctene	2	1	99
4	1-Octene	5	1	85
5	α -Methylstyrene	5	1	99
6	(R)-(+)-Limonene	5	1	90 ¹
7	Cholesterol	5	1	75 ²

Table 1: Representative substrate scope and yields for the 2,2,2-trifluoroacetophenone catalyzed epoxidation. Data sourced from Limnios & Kokotos, J. Org. Chem., 2014.[1][6] ¹ Yield for the mono-epoxide at the endocyclic double bond. ² Yield for the α -epoxide.

Troubleshooting and Key Considerations

- Low Yield:
 - Cause: Inefficient stirring. The reaction is biphasic, and vigorous mixing is essential for mass transport between the aqueous and organic layers.
 - Solution: Increase the stir rate to ensure the mixture appears as a homogenous emulsion.
 - Cause: Decomposition of H₂O₂.
 - Solution: Ensure the buffer is correctly prepared and free of metal contamination. Use fresh H₂O₂.
- Formation of Diol Byproduct:

- Cause: Acid-catalyzed hydrolysis of the epoxide product.
- Solution: Confirm the pH of the buffer is sufficiently high (pH ≈ 11). Ensure complete neutralization during work-up if acidic conditions are used.
- Reaction Stalls:
 - Cause: Catalyst deactivation. While robust, prolonged reaction times or highly reactive substrates could lead to side reactions.
 - Solution: Monitor the reaction closely by TLC/GC. If the reaction stalls, a small additional charge of the catalyst and H₂O₂ may be beneficial, though this protocol is typically complete within one hour.

Conclusion

The use of 2,2,2-trifluoroacetophenone as an organocatalyst for the epoxidation of alkenes represents a significant advancement in green chemistry.^[6] This protocol provides a fast, efficient, and inexpensive method to access valuable epoxide intermediates from a wide range of olefins, utilizing low catalyst loadings and the environmentally benign oxidant hydrogen peroxide.^{[1][7]} Its operational simplicity, mild conditions, and high yields make it an attractive and practical tool for researchers in both academic and industrial settings.

References

- Limnios, D., & Kokotos, C. G. (2014). 2,2,2-Trifluoroacetophenone: An Organocatalyst for an Environmentally Friendly Epoxidation of Alkenes. *The Journal of Organic Chemistry*, 79(10), 4270–4276. [\[Link\]](#)
- Organic Chemistry Portal. (n.d.). Synthesis of epoxides. Retrieved February 12, 2026, from [\[Link\]](#)
- Wikipedia. (2023). Shi epoxidation. In Wikipedia. Retrieved February 12, 2026, from [\[Link\]](#)
- Yadav, G. D., & Doshi, N. S. (2018). Journey Describing Applications of Oxone in Synthetic Chemistry. *ChemInform*, 49(36). [\[Link\]](#)

- Limnios, D., & Kokotos, C. G. (2014). 2,2,2-Trifluoroacetophenone: An Organocatalyst for an Environmentally Friendly Epoxidation of Alkenes. *The Journal of Organic Chemistry*, 79(10), 4270-4276. [[Link](#)]
- Kokotos, C. G., & Limnios, D. (2014). ChemInform Abstract: 2,2,2-Trifluoroacetophenone: An Organocatalyst for an Environmentally Friendly Epoxidation of Alkenes. *ChemInform*, 45(42). [[Link](#)]
- Limnios, D., & Kokotos, C. G. (2014). 2,2,2-Trifluoroacetophenone: an organocatalyst for an environmentally friendly epoxidation of alkenes. *The Journal of Organic Chemistry*, 79(10), 4270-4276. [[Link](#)]
- Organic Chemistry Portal. (n.d.). Shi Epoxidation. Retrieved February 12, 2026, from [[Link](#)]
- Chemistry LibreTexts. (2021, March 16). 5.3: Epoxidation of Unfunctionalized Alkenes. [[Link](#)]
- Chemistry Steps. (n.d.). Epoxidation of Alkenes. Retrieved February 12, 2026, from [[Link](#)]
- Organic Syntheses. (n.d.). In situ catalytic epoxidation of olefins with Oxone. Retrieved February 12, 2026, from [[Link](#)]
- Shi, Y. (2004). Ketone-Catalyzed Asymmetric Epoxidation Reactions. *Accounts of Chemical Research*, 37(8), 488–496. [[Link](#)]
- Myers, A. G. (n.d.). Shi Asymmetric Epoxidation Reaction. Harvard University. [[Link](#)]
- Taylor & Francis. (n.d.). Oxone – Knowledge and References. Retrieved February 12, 2026, from [[Link](#)]
- Chemistry LibreTexts. (2021, March 16). 5.3: Epoxidation of Unfunctionalized Alkenes. [[Link](#)]
- Chemistry Steps. (n.d.). The Mechanism of Epoxidation of Alkenes. Retrieved February 12, 2026, from [[Link](#)]

Need Custom Synthesis?

BenchChem offers custom synthesis for rare earth carbides and specific isotopic labeling.

Email: info@benchchem.com or [Request Quote Online](#).

Sources

- [1. pubs.acs.org \[pubs.acs.org\]](https://pubs.acs.org)
- [2. Epoxidation of Alkenes - Chemistry Steps \[chemistrysteps.com\]](https://chemistrysteps.com)
- [3. chem.libretexts.org \[chem.libretexts.org\]](https://chem.libretexts.org)
- [4. Shi epoxidation - Wikipedia \[en.wikipedia.org\]](https://en.wikipedia.org)
- [5. Shi Epoxidation \[organic-chemistry.org\]](https://organic-chemistry.org)
- [6. 2,2,2-Trifluoroacetophenone: An Organocatalyst for an Environmentally Friendly Epoxidation of Alkenes \[organic-chemistry.org\]](https://organic-chemistry.org)
- [7. 2,2,2-Trifluoroacetophenone: an organocatalyst for an environmentally friendly epoxidation of alkenes - PubMed \[pubmed.ncbi.nlm.nih.gov\]](https://pubmed.ncbi.nlm.nih.gov)
- [8. researchgate.net \[researchgate.net\]](https://researchgate.net)
- To cite this document: BenchChem. [Application Notes & Protocols: Epoxidation of Alkenes Using 2,2,2-Trifluoroacetophenone]. BenchChem, [2026]. [Online PDF]. Available at: [<https://www.benchchem.com/product/b065298/docs#application-notes-protocols-epoxidation-of-alkenes-using-2-2-2-trifluoroacetophenone>]

Disclaimer & Data Validity:

The information provided in this document is for Research Use Only (RUO) and is strictly not intended for diagnostic or therapeutic procedures. While BenchChem strives to provide accurate protocols, we make no warranties, express or implied, regarding the fitness of this product for every specific experimental setup.

Technical Support: The protocols provided are for reference purposes. Unsure if this reagent suits your experiment?

Need Industrial/Bulk Grade? [Request Custom Synthesis Quote](#)

BenchChem

Our mission is to be the trusted global source of essential and advanced chemicals, empowering scientists and researchers to drive progress in science and industry.

Contact

Address: 3281 E Guasti Rd

Ontario, CA 91761, United States

Phone: (601) 213-4426

Email: info@benchchem.com

[Contact our Ph.D. Support Team for a compatibility check](#)