

Benchmarking 2-Fluorodibenzothiophene: A Comparative Guide for Advanced OLED Applications

Author: BenchChem Technical Support Team. **Date:** May 2026

Compound of Interest

Compound Name:	2-Fluorodibenzothiophene
CAS No.:	177586-38-8
Cat. No.:	B064734

[Get Quote](#)

In the relentless pursuit of next-generation Organic Light-Emitting Diodes (OLEDs), particularly for high-energy blue emission, the molecular architecture of the organic materials employed is paramount. The development of efficient, stable, and color-pure blue emitters and hosts remains a significant bottleneck in the field, directly impacting the overall performance and longevity of full-color displays and solid-state lighting.[1][2] Dibenzothiophene derivatives have emerged as a promising class of materials, prized for their high thermal stability and excellent charge carrier mobility.[3] This guide provides a comprehensive performance benchmark of **2-Fluorodibenzothiophene**, a molecule of considerable interest.

While extensive experimental data for **2-Fluorodibenzothiophene** in published OLED devices is nascent, this guide will establish its performance profile through a synthesis of its core molecular attributes and the well-documented effects of fluorination on organic semiconductors. We will objectively compare its projected performance with established, state-of-the-art fluorescent, phosphorescent, and Thermally Activated Delayed Fluorescence (TADF) materials, supported by experimental data for these benchmarks.

The Strategic Advantage of the Dibenzothiophene Core

The dibenzothiophene (DBT) moiety is a rigid, planar heterocyclic structure that imparts several desirable characteristics for OLED applications:

- **High Triplet Energy (E_T):** The rigid structure of DBT results in a high triplet energy level. This is a critical prerequisite for host materials in phosphorescent OLEDs (PhOLEDs), as the host's triplet energy must be higher than that of the phosphorescent dopant to ensure efficient energy transfer and prevent back-transfer, which would quench the emission.
- **Excellent Thermal and Morphological Stability:** The fused ring system provides high thermal stability, crucial for the vacuum deposition manufacturing processes and for ensuring long operational lifetimes of the device.^[4]
- **Bipolar Charge Transport:** Dibenzothiophene derivatives can often exhibit ambipolar charge transport characteristics, facilitating a more balanced injection and transport of both holes and electrons. This leads to a wider recombination zone within the emissive layer and can help reduce efficiency roll-off at high brightness.

The Role of Fluorination: Enhancing the Core

The introduction of a fluorine atom at the 2-position of the dibenzothiophene core is a deliberate synthetic strategy intended to fine-tune its optoelectronic properties. Fluorination is a widely used tool in the design of organic electronic materials for several key reasons:

- **Energy Level Modification:** The strong electron-withdrawing nature of fluorine lowers both the Highest Occupied Molecular Orbital (HOMO) and Lowest Unoccupied Molecular Orbital (LUMO) energy levels. The lowering of the LUMO can facilitate more efficient electron injection from the cathode, while a deeper HOMO level can enhance stability by increasing resistance to oxidation.
- **Increased Electron Affinity:** A lower LUMO level corresponds to higher electron affinity, making the molecule a better electron transporter. This is particularly advantageous when designing host materials that need to efficiently transport electrons to the emissive dopant.

- Improved Photoluminescence Quantum Yield (PLQY): In some molecular contexts, fluorination can suppress non-radiative decay pathways, leading to an increase in the intrinsic fluorescence efficiency.
- Intermolecular Interaction Tuning: Fluorine substitution can influence the molecular packing in the solid state, which in turn affects charge mobility and film morphology.

Synthesizing these attributes, **2-Fluorodibenzothiophene** is projected to be an excellent candidate as a host material for blue phosphorescent or TADF emitters, offering high triplet energy, robust stability, and improved electron injection/transport properties compared to its non-fluorinated counterpart.

Comparative Performance Analysis

To contextualize the potential of **2-Fluorodibenzothiophene**, we compare its projected characteristics against leading materials from the three primary classes of OLED emitters.

Parameter	2-Fluorodibenzothiophene (Projected as Host)	v-DABNA (TADF Emitter)	Ir(ppy) ₃ in CBP Host (Phosphorescent System)	DCBz-pm (Fluorescent Emitter)
Material Class	Host for Phosphorescent/TADF	Thermally Activated Delayed Fluorescence (TADF)	Phosphorescent Emitter in Host	Fluorescent
Max. External Quantum Efficiency (EQE)	Dependent on Emitter	32.2% ^[1]	~20% (for green emission) ^[5]	4.36% ^[4]
Emission Color (CIE Coordinates)	N/A (Host)	Deep-Blue ^[1]	Green (0.33, 0.61)	Deep-Blue (0.158, 0.046) ^[4]
Triplet Energy (E _T)	High (Expected > 2.8 eV)	N/A (Emitter)	~2.4 eV (Ir(ppy) ₃)	N/A
Key Advantages	High thermal stability, good charge transport, high triplet energy, improved electron injection (projected).	High theoretical efficiency (up to 100% IQE), metal-free. ^[6]	High efficiency (near 100% IQE).	Good stability and long lifetime. ^[7]
Key Challenges	Performance is dopant-dependent.	Can have broader emission spectra and stability issues. ^[8]	Requires heavy metals (Iridium, Platinum), blue variants often have shorter lifetimes. ^{[9][10]}	Limited theoretical EQE (~5%). ^[1]

CBP: 4,4'-Bis(N-carbazolyl)-1,1'-biphenyl

This comparison highlights the trade-offs inherent in OLED material selection. While fluorescent emitters offer stability, their efficiency is fundamentally limited.^[7] Phosphorescent and TADF materials overcome this efficiency barrier, but often face challenges with lifetime, particularly for deep-blue emitters.^[6]^[9] **2-Fluorodibenzothiophene**, as a host, is strategically positioned to enhance the performance of these high-efficiency emitters by providing a stable, high-energy environment with improved charge dynamics.

Experimental Benchmarking Protocols

To validate the performance of any new OLED material, a rigorous and standardized set of fabrication and characterization protocols is essential. The following methodologies provide a self-validating system for benchmarking.

OLED Device Fabrication (Vacuum Thermal Evaporation)

The causality for this multi-layer approach is to confine charge carriers (electrons and holes) within the emissive layer, maximizing their probability of recombination and subsequent light emission.^[11]

- Substrate Preparation:
 - Begin with patterned Indium Tin Oxide (ITO)-coated glass substrates.
 - Sequentially clean the substrates in an ultrasonic bath with detergent, deionized water, acetone, and isopropanol for 15 minutes each. This rigorous cleaning is critical to remove organic and particulate contaminants that can cause short circuits.
 - Dry the substrates in an oven at 120°C for 30 minutes to remove residual solvent.
 - Immediately before loading into the deposition chamber, treat the substrates with UV-Ozone for 10 minutes to increase the work function of the ITO and improve hole injection.
- Organic and Metal Layer Deposition:
 - Transfer the substrates to a high-vacuum thermal evaporation chamber (base pressure < 10⁻⁶ Torr). The vacuum environment prevents oxidation and contamination of the organic layers during deposition.

- Deposit the following layers sequentially. The thickness of each layer is monitored in-situ using a quartz crystal microbalance.
 - Hole Injection Layer (HIL): Deposit a 30 nm layer of a suitable HIL material (e.g., HAT-CN). This layer facilitates the injection of holes from the ITO anode.
 - Hole Transport Layer (HTL): Deposit a 40 nm layer of a hole-transporting material (e.g., TAPC). This layer transports holes to the emissive layer while blocking electrons.
 - Emissive Layer (EML): Co-evaporate the host material (e.g., **2-Fluorodibenzothiophene**) and the guest emitter (dopant) from separate sources. A typical doping concentration is 5-15 wt%. The layer thickness is typically 20 nm.
 - Electron Transport Layer (ETL): Deposit a 30 nm layer of an electron-transporting material (e.g., TPBi). This layer transports electrons from the cathode and blocks holes.
 - Electron Injection Layer (EIL): Deposit a 1 nm layer of Lithium Fluoride (LiF). This thin layer lowers the work function of the cathode, dramatically improving electron injection.
- Cathode Deposition: Deposit a 100 nm layer of Aluminum (Al) as the cathode without breaking the vacuum.
- Encapsulation:
 - Immediately transfer the completed device to a nitrogen-filled glovebox without exposure to air or moisture.
 - Encapsulate the device using a UV-curable epoxy and a glass coverslip. A desiccant is often included within the encapsulated space to absorb any residual moisture. Encapsulation is crucial as organic materials and the reactive cathode are highly susceptible to degradation from oxygen and water.[\[12\]](#)

Device Characterization

- Current Density-Voltage-Luminance (J-V-L) Characteristics:
 - Use a source measure unit (SMU) and a calibrated photodiode/spectrometer.

- Apply a forward voltage bias to the device and measure the resulting current and light output simultaneously.
- This measurement determines the turn-on voltage, luminance (in cd/m^2), and current density (in mA/cm^2).
- Efficiency Calculations:
 - External Quantum Efficiency (EQE): This is the ratio of photons emitted from the device to the number of electrons injected.[13] It is calculated from the luminance, current density, and the electroluminescence spectrum. High EQE is a primary goal of OLED research.[6] [14]
 - Current Efficiency: Measured in candela per ampere (cd/A).
 - Power Efficiency: Measured in lumens per watt (lm/W).
- Electroluminescence (EL) Spectrum and CIE Coordinates:
 - Measure the EL spectrum using a spectroradiometer at a constant driving current.
 - From the spectrum, calculate the Commission Internationale de l'Éclairage (CIE) 1931 color coordinates (x, y) to quantify the exact color of the emitted light.[15]
- Operational Lifetime:
 - Test the device stability by applying a constant DC current to achieve an initial luminance (e.g., 1000 cd/m^2).
 - Monitor the luminance over time. The lifetime is often reported as LT50 or LT95, the time it takes for the luminance to decay to 50% or 95% of its initial value, respectively.[9]

Visualizing the Framework for OLED Benchmarking

OLED Device Architecture

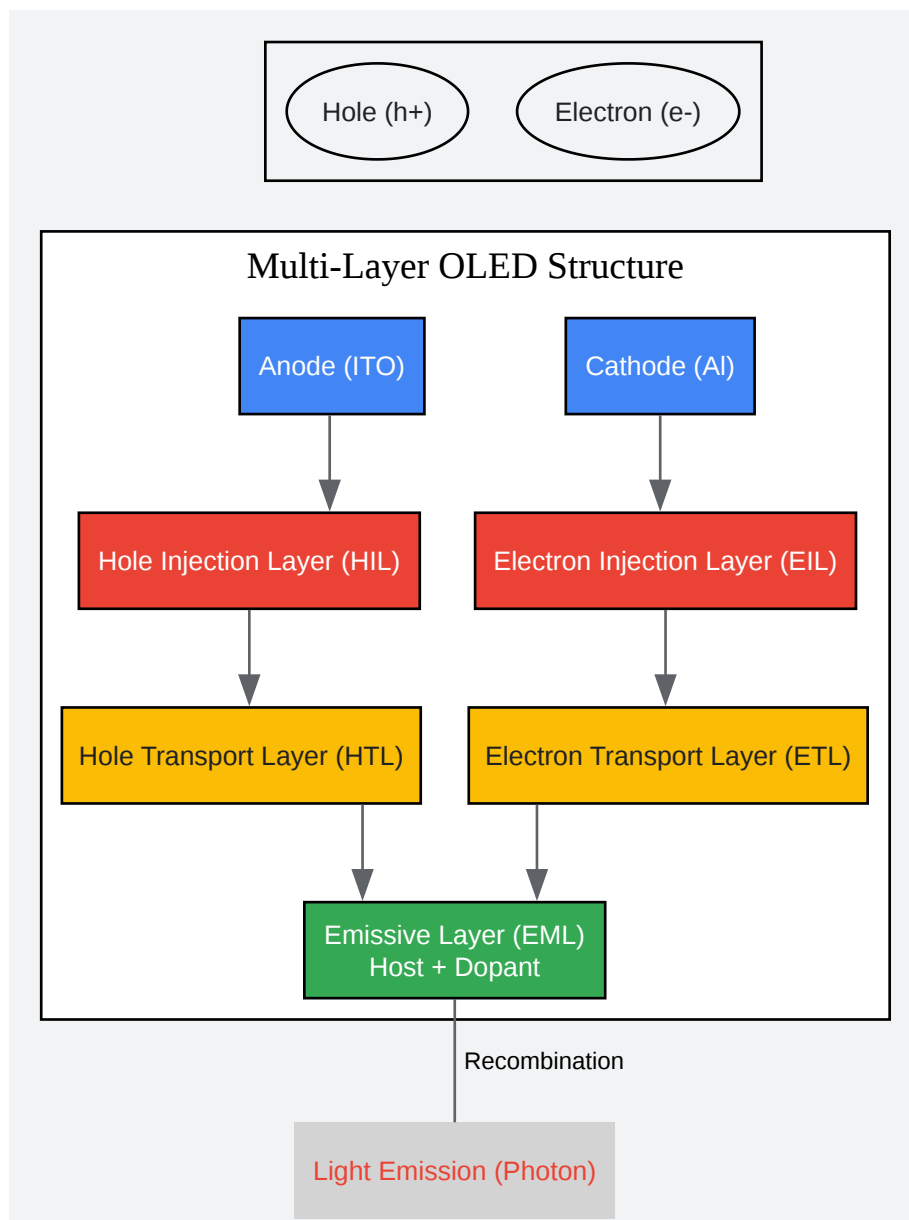

[Click to download full resolution via product page](#)

Caption: A typical multi-layer OLED device structure.

Experimental Workflow for Performance Evaluation

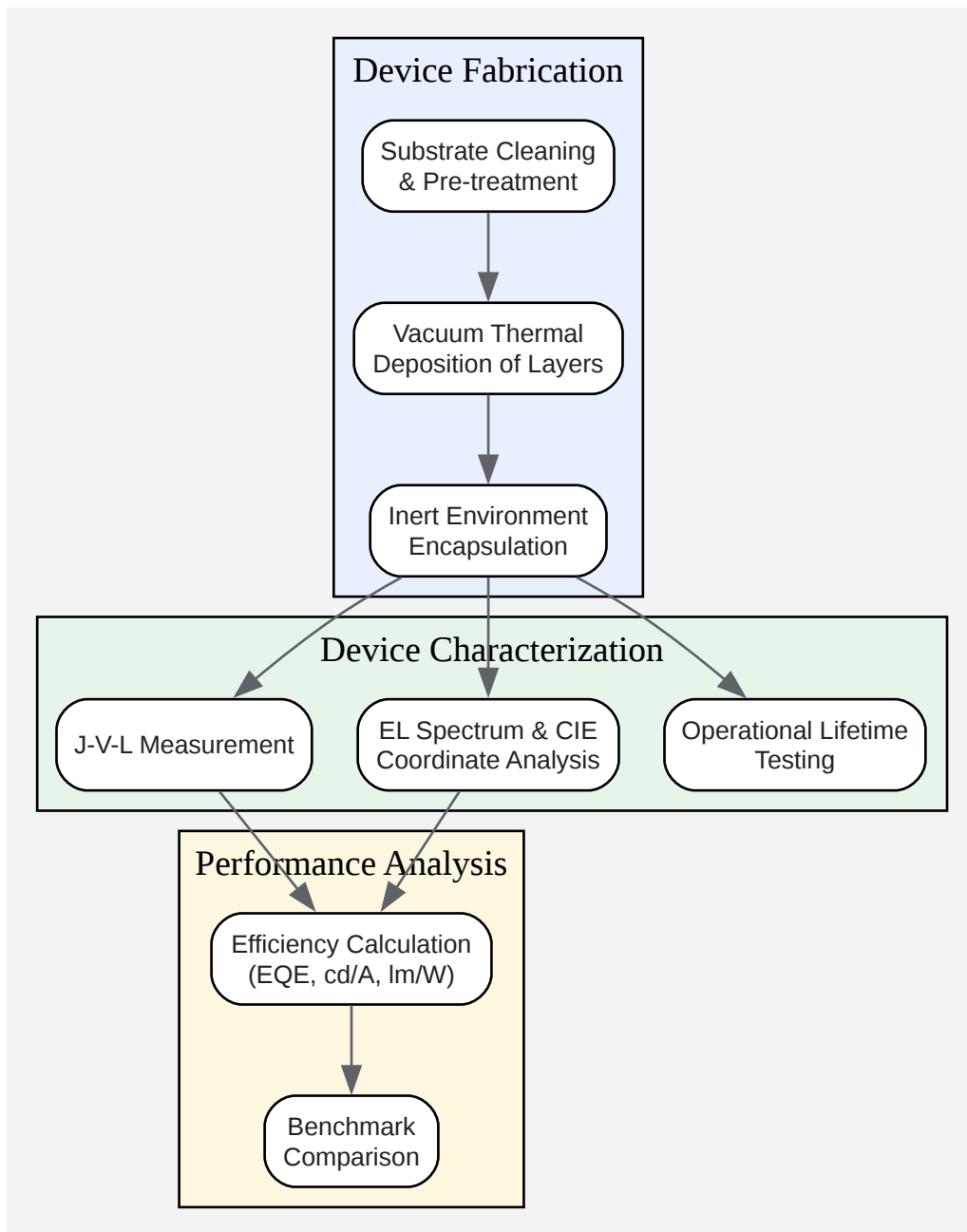

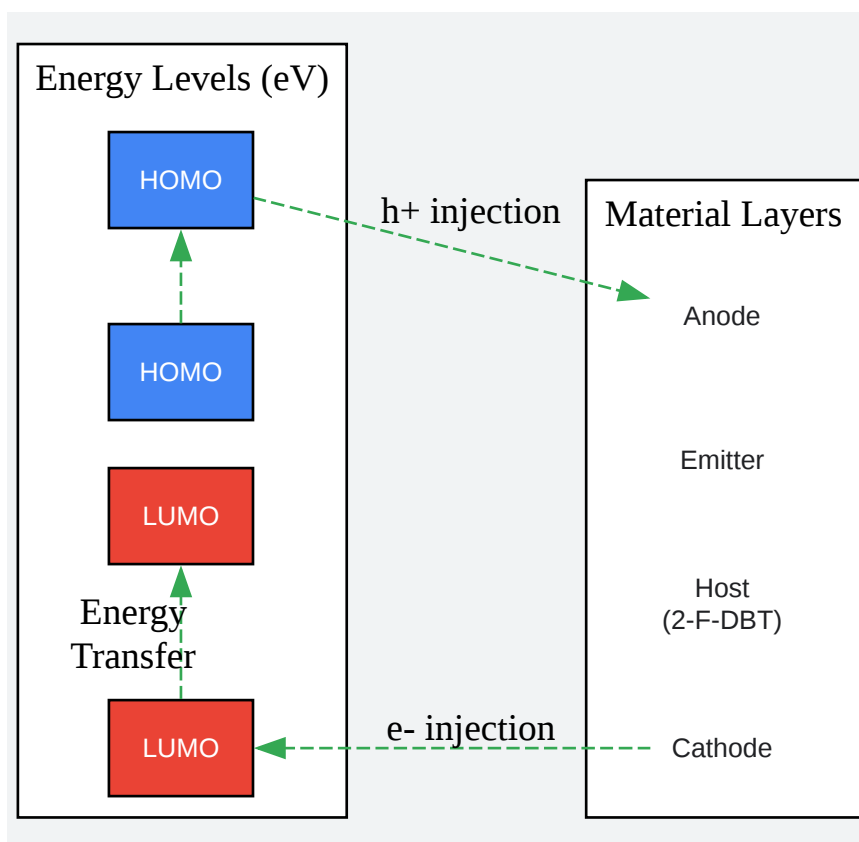

[Click to download full resolution via product page](#)

Need Custom Synthesis?

BenchChem offers custom synthesis for rare earth carbides and specific isotopic labeling.

Email: info@benchchem.com or [Request Quote Online](#).

Sources

- [1. mdpi.com](https://www.mdpi.com) [[mdpi.com](https://www.mdpi.com)]
- [2. displaydaily.com](https://www.displaydaily.com) [[displaydaily.com](https://www.displaydaily.com)]
- [3. New \[1\]benzothieno\[3,2-b\]benzothiophene-tetraoxide-based TADF emitters with a D–A–D structure for OLED applications - Journal of Materials Chemistry C \(RSC Publishing\)](#) [pubs.rsc.org]
- [4. researchgate.net](https://www.researchgate.net) [[researchgate.net](https://www.researchgate.net)]
- [5. researchgate.net](https://www.researchgate.net) [[researchgate.net](https://www.researchgate.net)]

- 6. Key Factors Governing the External Quantum Efficiency of Thermally Activated Delayed Fluorescence Organic Light-Emitting Devices: Evidence from Machine Learning - PMC [[pmc.ncbi.nlm.nih.gov](https://pubmed.ncbi.nlm.nih.gov/)]
- 7. Recent advances in high performance blue organic light-emitting diodes based on fluorescence emitters - Journal of Materials Chemistry C (RSC Publishing) [pubs.rsc.org]
- 8. oled-info.com [oled-info.com]
- 9. The Blue Problem: OLED Stability and Degradation Mechanisms - PMC [[pmc.ncbi.nlm.nih.gov](https://pubmed.ncbi.nlm.nih.gov/)]
- 10. ece.engin.umich.edu [ece.engin.umich.edu]
- 11. researchgate.net [researchgate.net]
- 12. m.youtube.com [m.youtube.com]
- 13. researchgate.net [researchgate.net]
- 14. researchgate.net [researchgate.net]
- 15. Optimization of the cavity in a blue OLED. CIE coordinates — Fluxim [fluxim.com]
- To cite this document: BenchChem. [Benchmarking 2-Fluorodibenzothiophene: A Comparative Guide for Advanced OLED Applications]. BenchChem, [2026]. [Online PDF]. Available at: [<https://www.benchchem.com/product/b064734/docs#benchmarking-2-fluorodibenzothiophene-a-comparative-guide-for-advanced-oled-applications>]

Disclaimer & Data Validity:

The information provided in this document is for Research Use Only (RUO) and is strictly not intended for diagnostic or therapeutic procedures. While BenchChem strives to provide accurate protocols, we make no warranties, express or implied, regarding the fitness of this product for every specific experimental setup.

Technical Support: The protocols provided are for reference purposes. Unsure if this reagent suits your experiment?

Need Industrial/Bulk Grade? [Request Custom Synthesis Quote](#)

BenchChem

Our mission is to be the trusted global source of essential and advanced chemicals, empowering scientists and researchers to drive progress in science and industry.

Contact

Address: 3281 E Guasti Rd

Ontario, CA 91761, United States

Phone: (601) 213-4426

Email: info@benchchem.com

[Contact our Ph.D. Support Team for a compatibility check](#)