

Resolving decarboxylation issues during picolinic acid synthesis

Author: BenchChem Technical Support Team. **Date:** April 2026

Compound of Interest

Compound Name:	4-(2-Formylthiophen-4-YL)picolinic acid
CAS No.:	1261896-83-6
Cat. No.:	B6387908

[Get Quote](#)

Welcome to the Technical Support Center for Heterocyclic Synthesis. As a Senior Application Scientist, I frequently encounter researchers struggling with the spontaneous degradation of 2-substituted pyridines. This guide is specifically engineered to troubleshoot and resolve decarboxylation issues during the synthesis and isolation of picolinic acid.

Diagnostic FAQs: Mechanistic Insights

Q: Why does picolinic acid spontaneously decarboxylate during my oxidation workup, whereas nicotinic acid (the 3-isomer) remains completely stable? A: The instability of picolinic acid is deeply rooted in its electronic structure. The nitrogen atom at the 2-position of the pyridine ring acts as a powerful electron-withdrawing group. During thermal stress, picolinic acid forms a zwitterionic species that readily undergoes decarboxylation to generate a highly stabilized pyridine-2-ylidene carbene or ylide intermediate[1][2]. This C-C bond cleavage is the fundamental step of the Hammick reaction[1]. Nicotinic acid lacks this direct stabilization at the 3-position, making its carboxyl group significantly more robust against thermal cleavage.

Q: I am using aqueous potassium permanganate (KMnO_4) to oxidize 2-picoline. How do I prevent the formation of pyridine? A: Pyridine formation is the direct macroscopic symptom of thermal decarboxylation. In the laboratory, picolinic acid is synthesized from 2-methylpyridine (2-picoline) via KMnO_4 oxidation[3]. If the reaction temperature exceeds 80–90°C, the thermal energy surpasses the activation barrier for C-C bond cleavage[2]. You must maintain the reaction strictly between 70–80°C. Furthermore, prolonged heating during the concentration of the aqueous filtrate must be avoided; always concentrate under reduced pressure at lower temperatures.

Q: Does the choice of solvent or the presence of trace metals impact the decarboxylation rate? A: Absolutely. Water plays a critical role by forming a hydrogen-bonded bridge between the carboxylate oxygen and the aromatic nitrogen, which lowers the activation energy for decarboxylation[2]. Additionally, transition metals—specifically Copper (Cu^{2+}) and Silver (Ag^+)—act as potent catalysts for this process. They form carboxylate complex intermediates that treat the aryl carboxylate as an aryl anion synthon, drastically accelerating CO_2 loss[4]. Ensure all glassware and reagents are free of trace transition metals unless you are intentionally performing a decarboxylative cross-coupling reaction.

Quantitative Data on Oxidation Strategies

Selecting the right oxidation method is a balance between yield and decarboxylation risk. Below is a comparative analysis of standard 2-picoline oxidation methods.

Oxidation Method	Typical Temperature	Decarboxylation Risk	Typical Yield	Mechanistic Notes
Aqueous KMnO ₄	70–80 °C	Low to Moderate	50–60%	Requires strict temperature control to prevent thermal ylide formation[3].
V ₂ O ₅ /TiO ₂ Catalytic Air	240–300 °C	High	~88%	Gas-phase reaction; short residence time prevents complete degradation to pyridine[5].
Nitric Acid Oxidation	>100 °C	High	Variable	Acidic conditions at high heat accelerate zwitterion decomposition.

Visualizing the Decarboxylation Pathway

Understanding the pathway is critical to disrupting it. The diagram below illustrates the Hammick-type decarboxylation mechanism that must be avoided.

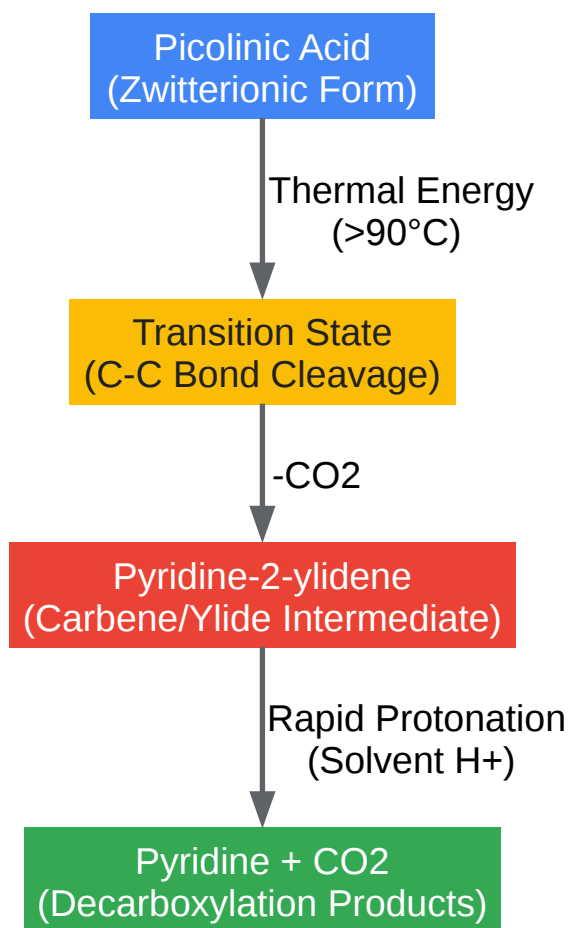

[Click to download full resolution via product page](#)

Mechanism of thermal decarboxylation of picolinic acid via a reactive ylide.

Troubleshooting Guide & Process Optimization

Use the following logical workflow to identify and eliminate the root causes of decarboxylation during your synthesis and workup phases.

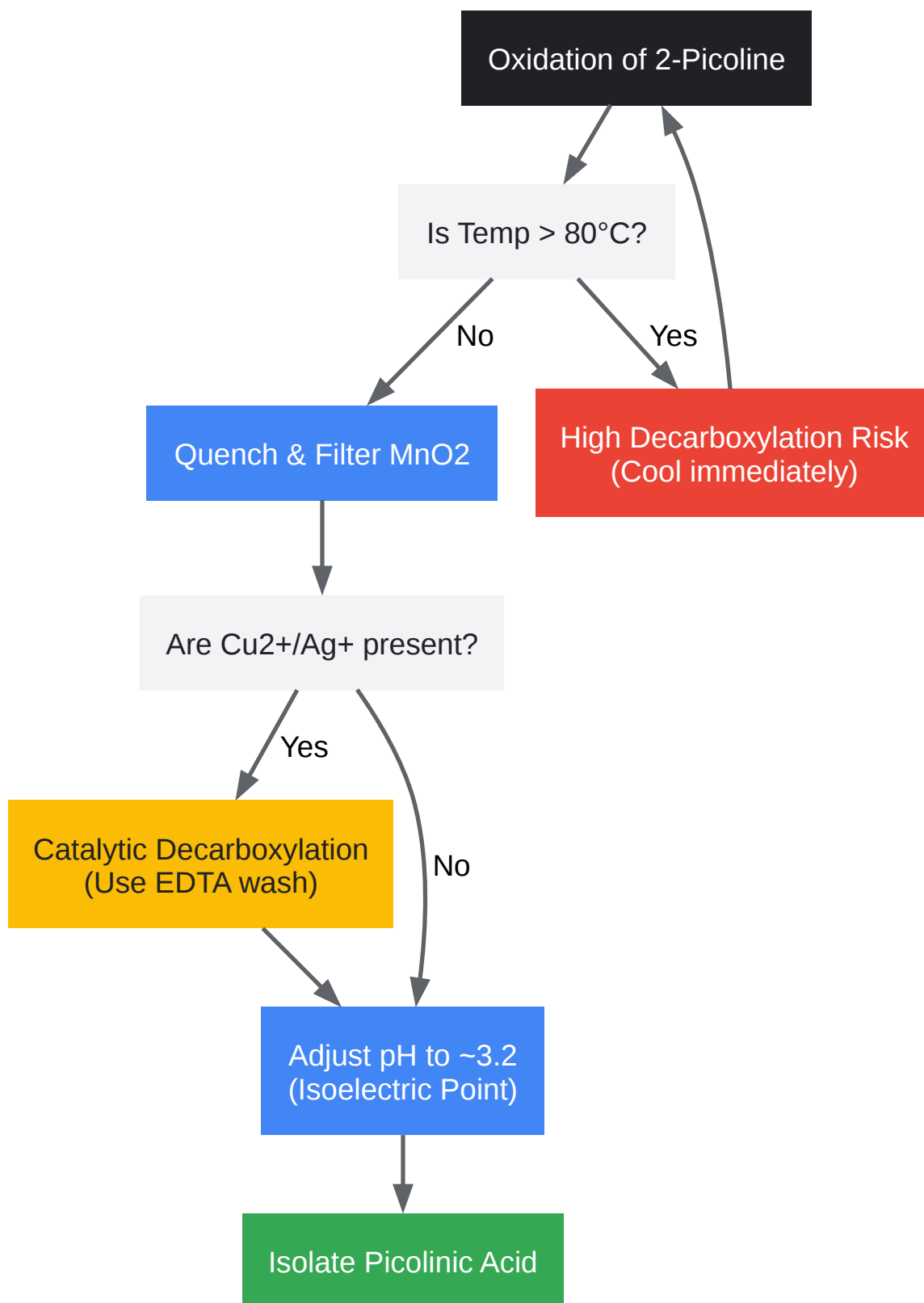

[Click to download full resolution via product page](#)

Troubleshooting decision tree to mitigate decarboxylation during synthesis.

Self-Validating Experimental Protocol

Protocol: Controlled KMnO_4 Oxidation of 2-Picoline with In-Line Decarboxylation Monitoring

Causality Focus: By maintaining the temperature strictly below 80°C , we deny the system the thermal activation energy required to transition the zwitterionic picolinate into the pyridine-2-ylidene carbene, thereby preserving the C-C bond.

Step 1: Reagent Preparation Dissolve 0.1 mol of 2-picoline in 100 mL of deionized water in a 500 mL round-bottom flask equipped with a robust magnetic stirrer and an internal thermocouple.

Step 2: Controlled Oxidation Begin heating the solution to 70°C . Slowly add 0.25 mol of solid KMnO_4 in small portions over 2 hours. Critical Control: The oxidation is highly exothermic. Monitor the internal thermocouple continuously. If the temperature approaches 80°C , pause the addition and apply an ice bath.

Step 3: Quenching & Filtration Once the purple color dissipates (indicating complete KMnO_4 consumption), filter the precipitated manganese dioxide (MnO_2) over a pad of Celite while the solution is still warm (approx. 50°C). Do not boil the filtrate to concentrate it.

Step 4: Isolation & pH Control Cool the clear filtrate to room temperature. Carefully adjust the pH to approximately 3.2 (the isoelectric point of picolinic acid) using dilute HCl. Chill the solution to 4°C overnight to induce crystallization of the white solid product.

Step 5: Self-Validation (Analytical Check) To validate that decarboxylation was successfully suppressed, sample the headspace of the reaction vessel using Solid-Phase Microextraction (SPME) and analyze via GC-MS. The absence of a peak at m/z 79 (pyridine) confirms the structural integrity of the picolinic acid throughout the workflow.

References

- Picolinic acid - Wikipedia. [wikipedia.org](https://en.wikipedia.org/wiki/Picolinic_acid).
- Hammick reaction - Grokipedia. [grokipedia.com](https://grokipedia.com/en/Hammick_reaction).
- Kinetics and mechanism of decarboxylation of some pyridinecarboxylic acids in aqueous solution. II - ResearchGate.
- Decarboxyl
- CN101623648A - Catalyst of picolinic acid synthesized by selectively oxygenizing picoline as well as preparation method and application thereof - Google P

Need Custom Synthesis?

BenchChem offers custom synthesis for rare earth carbides and specific isotopic labeling.

Email: info@benchchem.com or [Request Quote Online](#).

Sources

- [1. grokipedia.com \[grokipedia.com\]](https://grokipedia.com)
- [2. researchgate.net \[researchgate.net\]](https://researchgate.net)
- [3. Picolinic acid - Wikipedia \[en.wikipedia.org\]](https://en.wikipedia.org)
- [4. Decarboxylation - Wikipedia \[en.wikipedia.org\]](https://en.wikipedia.org)
- [5. CN101623648A - Catalyst of picolinic acid synthesized by selectively oxygenizing picoline as well as preparation method and application thereof - Google Patents \[patents.google.com\]](#)
- To cite this document: BenchChem. [Resolving decarboxylation issues during picolinic acid synthesis]. BenchChem, [2026]. [Online PDF]. Available at: [\[https://www.benchchem.com/product/b6387908/docs#resolving-decarboxylation-issues-during-picolinic-acid-synthesis\]](https://www.benchchem.com/product/b6387908/docs#resolving-decarboxylation-issues-during-picolinic-acid-synthesis)

Disclaimer & Data Validity:

The information provided in this document is for Research Use Only (RUO) and is strictly not intended for diagnostic or therapeutic procedures. While BenchChem strives to provide accurate protocols, we make no warranties, express or implied, regarding the fitness of this product for every specific experimental setup.

Technical Support: The protocols provided are for reference purposes. Unsure if this reagent suits your experiment?

Need Industrial/Bulk Grade? [Request Custom Synthesis Quote](#)

BenchChem

Our mission is to be the trusted global source of essential and advanced chemicals, empowering scientists and researchers to drive progress in science and industry.

Contact

Address: 3281 E Guasti Rd

Ontario, CA 91761, United States

Phone: (601) 213-4426

Email: info@benchchem.com

[Contact our Ph.D. Support Team for a compatibility check](#)