

Introduction: The Significance of Biaryl Scaffolds

Author: BenchChem Technical Support Team. **Date:** April 2026

Compound of Interest

Compound Name: 4-(3-Cyanophenyl)-2-nitrophenol

CAS No.: 1261932-80-2

Cat. No.: B6382488

[Get Quote](#)

Biaryl structures are privileged motifs in medicinal chemistry and materials science, forming the core of numerous pharmaceuticals, agrochemicals, and organic electronic materials.[1] The targeted compound, **4-(3-Cyanophenyl)-2-nitrophenol**, combines several key functional groups: a phenolic hydroxyl, a nitro group, a cyano group, and the biaryl linkage. This unique combination makes it an attractive intermediate for further chemical elaboration. The synthesis of such molecules with high efficiency and selectivity is a critical task in modern organic chemistry, frequently addressed through palladium-catalyzed cross-coupling reactions.[2][3]

Retrosynthetic Analysis and Strategic Approach

The most logical and robust approach for constructing the central carbon-carbon bond in **4-(3-Cyanophenyl)-2-nitrophenol** is the Suzuki-Miyaura cross-coupling reaction.[4] This powerful palladium-catalyzed method involves the coupling of an organoboron species with an organohalide. Our retrosynthetic analysis, therefore, disconnects the target molecule into two key precursors: 4-Bromo-2-nitrophenol and 3-Cyanophenylboronic acid.

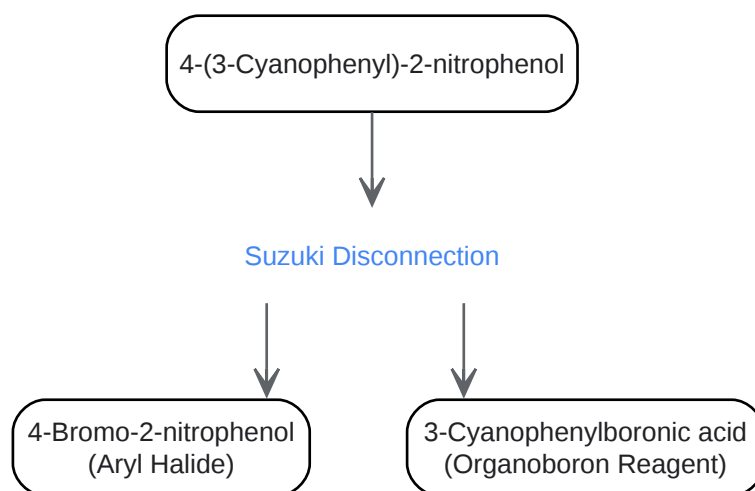

[Click to download full resolution via product page](#)

Caption: Retrosynthetic analysis of the target compound.

This strategy allows for a convergent synthesis where the two key fragments are prepared separately and then combined in a final, high-yielding step.

Part 1: Synthesis of Key Precursors

The success of the final coupling step is contingent upon the availability of high-purity starting materials.

Synthesis of 4-Bromo-2-nitrophenol

This precursor is synthesized via electrophilic nitration of p-bromophenol. The hydroxyl group is a strongly activating, ortho-, para-directing group. Since the para position is blocked by the bromine atom, the incoming nitro group is directed primarily to the ortho position.

Experimental Protocol: Nitration of p-Bromophenol

- **Reaction Setup:** In a 250 mL round-bottom flask equipped with a magnetic stir bar and a dropping funnel, dissolve p-bromophenol (10.0 g, 57.8 mmol) in 50 mL of glacial acetic acid. Cool the flask in an ice-water bath to 0-5 °C.
- **Nitrating Agent Preparation:** In a separate beaker, cautiously prepare the nitrating mixture by adding concentrated nitric acid (4.5 mL, ~71.7 mmol) to 10 mL of glacial acetic acid.

- **Reaction:** Add the nitrating mixture dropwise to the stirred solution of p-bromophenol over 30 minutes, ensuring the internal temperature does not exceed 10 °C.
- **Quenching and Isolation:** After the addition is complete, allow the reaction to stir at room temperature for 1 hour. Pour the reaction mixture slowly into 200 mL of ice-cold water with vigorous stirring. A yellow precipitate will form.
- **Purification:** Collect the solid product by vacuum filtration, wash thoroughly with cold water until the filtrate is neutral, and dry in a vacuum oven. The crude product can be recrystallized from an ethanol/water mixture to yield pure 4-Bromo-2-nitrophenol.[5][6]

Property	Value	Source
CAS Number	7693-52-9	[7]
Molecular Formula	C ₆ H ₄ BrNO ₃	[6]
Molecular Weight	218.00 g/mol	[6]
Appearance	Yellow Crystalline Solid	[6]
Melting Point	90-94 °C	[6]

Table 1: Physicochemical Properties of 4-Bromo-2-nitrophenol.

Preparation of 3-Cyanophenylboronic acid

3-Cyanophenylboronic acid is a versatile reagent used in a variety of cross-coupling reactions. [8] While it is commercially available from numerous suppliers, a synthesis protocol from 3-bromobenzonitrile is provided here for completeness. The mechanism involves a lithium-halogen exchange followed by reaction with a trialkyl borate and subsequent acidic hydrolysis. [9]

Experimental Protocol: Synthesis from 3-Bromobenzonitrile

- **Reaction Setup:** To a flame-dried, three-neck flask under a nitrogen atmosphere, add 3-bromobenzonitrile (5.0 g, 27.5 mmol) and 100 mL of anhydrous tetrahydrofuran (THF). Cool

the solution to $-78\text{ }^{\circ}\text{C}$ using a dry ice/acetone bath.

- Lithiation: Slowly add n-butyllithium (1.6 M in hexanes, 18.9 mL, 30.2 mmol) dropwise, maintaining the temperature at $-78\text{ }^{\circ}\text{C}$. Stir for 30 minutes.
- Borylation: Add triisopropyl borate (7.6 mL, 33.0 mmol) dropwise. After addition, remove the cooling bath and allow the mixture to warm to room temperature and stir for 2 hours.
- Hydrolysis and Work-up: Cool the mixture to $0\text{ }^{\circ}\text{C}$ and quench by the slow addition of 2 M hydrochloric acid until the pH is ~ 2 . Transfer the mixture to a separatory funnel and extract with ethyl acetate (3 x 50 mL).
- Purification: Combine the organic layers, dry over anhydrous magnesium sulfate, filter, and concentrate under reduced pressure. The resulting solid can be recrystallized to yield pure 3-Cyanophenylboronic acid.[9]

Property	Value	Source
CAS Number	150255-96-2	[10]
Molecular Formula	$\text{C}_7\text{H}_6\text{BNO}_2$	[10]
Molecular Weight	146.94 g/mol	[10]
Appearance	White to Light Yellow Solid	[9]
Melting Point	$>298\text{ }^{\circ}\text{C}$ (decomposes)	

Table 2: Physicochemical Properties of 3-Cyanophenylboronic acid.

Part 2: The Suzuki-Miyaura Cross-Coupling Reaction

This section details the core reaction for assembling the biaryl structure. The palladium-catalyzed Suzuki-Miyaura reaction is renowned for its mild conditions and high functional group tolerance.[4][11]

Catalytic Cycle Mechanism

The reaction proceeds through a well-established catalytic cycle involving a palladium(0) species.

- Oxidative Addition: The active Pd(0) catalyst oxidatively adds to the aryl halide (4-bromo-2-nitrophenol), forming a Pd(II) complex.
- Transmetalation: The boronic acid, activated by a base to form a boronate complex, transfers its organic group (the 3-cyanophenyl moiety) to the Pd(II) center, displacing the halide.
- Reductive Elimination: The two organic groups on the palladium complex couple and are eliminated, forming the desired biaryl product and regenerating the active Pd(0) catalyst, which re-enters the cycle.^[4]

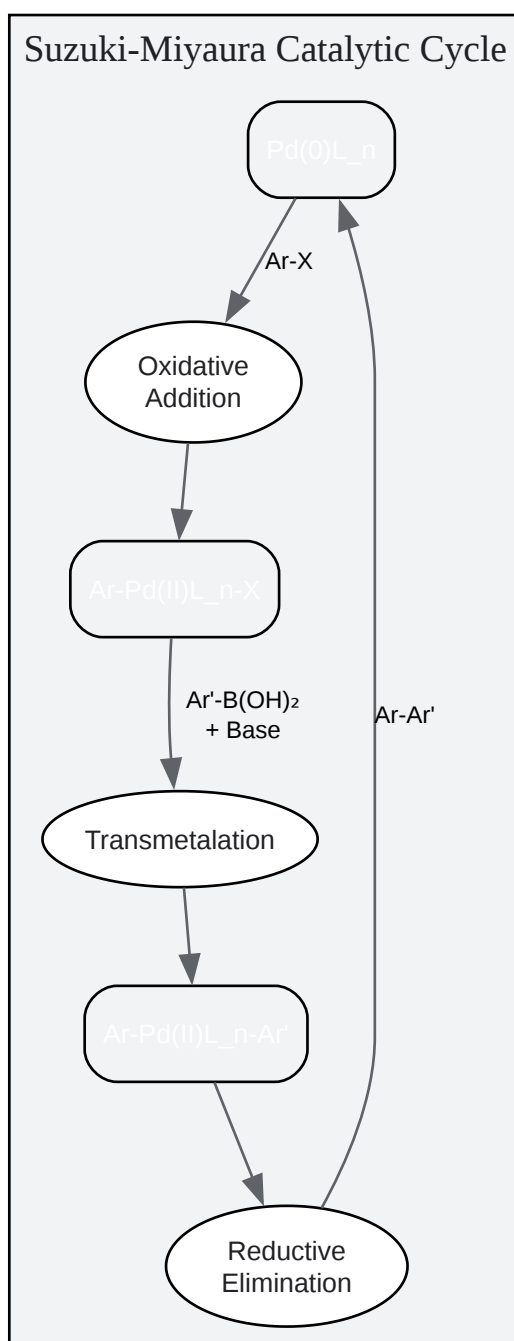

[Click to download full resolution via product page](#)

Caption: The catalytic cycle of the Suzuki-Miyaura reaction.

Detailed Experimental Protocol

Expertise in Action: The choice of catalyst, ligand, and base is critical. We use Pd(OAc)_2 as a stable Pd(II) precatalyst, which is reduced in situ to the active Pd(0) species. SPhos (2-

Dicyclohexylphosphino-2',6'-dimethoxybiphenyl) is selected as the ligand; its bulk and electron-donating properties promote both the oxidative addition and reductive elimination steps, leading to higher efficiency.[1] Potassium phosphate (K_3PO_4) is a moderately strong base effective for this transformation.

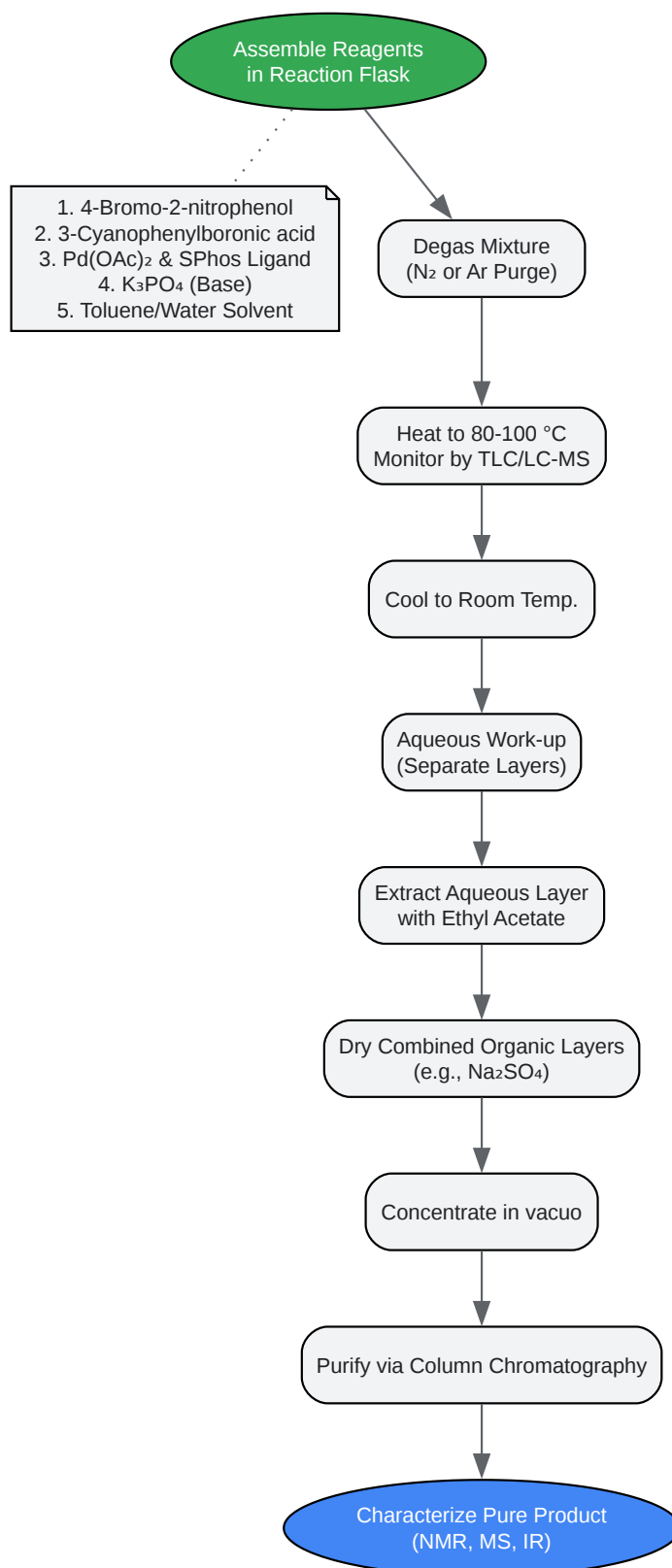

[Click to download full resolution via product page](#)

Caption: General experimental workflow for the synthesis.

Reagents & Conditions:

Reagent/Component	Molar Eq.	Amount (for 10 mmol scale)	Purpose
4-Bromo-2-nitrophenol	1.0	2.18 g	Aryl halide electrophile
3-Cyanophenylboronic acid	1.2	1.76 g	Organoboron nucleophile
Palladium(II) Acetate	0.02	45 mg	Catalyst precursor
SPhos	0.04	164 mg	Ligand for catalyst stabilization
Potassium Phosphate (K ₃ PO ₄)	3.0	6.37 g	Base for boronic acid activation
Toluene	-	80 mL	Organic solvent
Water	-	20 mL	Co-solvent to dissolve inorganic base

Table 3: Reagents for Suzuki-Miyaura Coupling Reaction.

Procedure:

- **Setup:** To a 250 mL Schlenk flask, add 4-Bromo-2-nitrophenol (2.18 g, 10.0 mmol), 3-Cyanophenylboronic acid (1.76 g, 12.0 mmol), Palladium(II) acetate (45 mg, 0.2 mmol), SPhos (164 mg, 0.4 mmol), and potassium phosphate (6.37 g, 30.0 mmol).
- **Solvent Addition & Degassing:** Add toluene (80 mL) and water (20 mL). Seal the flask and thoroughly degas the mixture by bubbling nitrogen or argon through the solution for 15-20 minutes. This step is crucial to remove oxygen, which can deactivate the palladium catalyst.
- **Reaction:** Heat the reaction mixture to 90 °C with vigorous stirring under a nitrogen atmosphere. Monitor the reaction progress by Thin Layer Chromatography (TLC) or LC-MS

until the starting 4-bromo-2-nitrophenol is consumed (typically 4-12 hours).

- Work-up: Cool the reaction to room temperature. Dilute the mixture with 100 mL of ethyl acetate and transfer to a separatory funnel. Wash the organic layer with water (2 x 50 mL) and then with brine (50 mL).
- Isolation: Separate the organic layer, dry it over anhydrous sodium sulfate, filter, and concentrate the solvent using a rotary evaporator.

Part 3: Purification and Characterization

The crude product obtained after work-up will likely contain residual catalyst, ligand, and potentially some side products. Purification is essential to obtain the target compound in high purity.

Purification Protocol

Silica Gel Column Chromatography: The most common and effective method for purifying this type of compound is column chromatography.

- Slurry Preparation: Adsorb the crude product onto a small amount of silica gel.
- Column Packing: Pack a glass column with silica gel using a suitable solvent system, such as a gradient of ethyl acetate in hexanes (e.g., starting from 10:90 and gradually increasing the polarity).
- Elution: Carefully load the adsorbed crude product onto the top of the column and elute with the chosen solvent system, collecting fractions.
- Analysis: Analyze the collected fractions by TLC to identify those containing the pure product.
- Final Step: Combine the pure fractions and remove the solvent under reduced pressure to yield **4-(3-Cyanophenyl)-2-nitrophenol** as a solid.

Characterization

The identity and purity of the final compound should be confirmed using standard analytical techniques.

- ^1H NMR Spectroscopy: The proton NMR spectrum should show distinct aromatic signals corresponding to both phenyl rings, as well as a characteristic signal for the phenolic -OH proton.
- ^{13}C NMR Spectroscopy: The carbon NMR will confirm the presence of all carbon atoms, including the quaternary carbons of the biaryl linkage and the distinct signal for the nitrile carbon ($-\text{C}\equiv\text{N}$).
- Mass Spectrometry (MS): High-resolution mass spectrometry (HRMS) will confirm the molecular formula by providing a highly accurate molecular weight.
- Infrared (IR) Spectroscopy: The IR spectrum will show characteristic absorption bands for the O-H stretch (phenol), the $\text{C}\equiv\text{N}$ stretch (nitrile), and the asymmetric and symmetric N-O stretches of the nitro group.[12]

Safety and Handling

- Reagents: Handle concentrated nitric acid, organic solvents, and palladium catalysts with appropriate personal protective equipment (PPE), including gloves, safety glasses, and a lab coat. Perform all operations in a well-ventilated fume hood.
- Reactions: The nitration reaction is exothermic and must be controlled with proper cooling. Cross-coupling reactions should be conducted under an inert atmosphere to prevent catalyst degradation and potential side reactions.
- Waste Disposal: Dispose of all chemical waste, especially heavy-metal-containing residues from the palladium catalyst, according to institutional and local environmental regulations.

Conclusion

The synthesis of **4-(3-Cyanophenyl)-2-nitrophenol** is reliably achieved through a convergent strategy centered on a Suzuki-Miyaura cross-coupling reaction. By carefully preparing the requisite precursors, 4-Bromo-2-nitrophenol and 3-Cyanophenylboronic acid, and by employing optimized reaction conditions with a suitable palladium catalyst system, the target biaryl

compound can be obtained in good yield and high purity. The protocols and rationale outlined in this guide provide a robust framework for researchers to successfully execute this synthesis.

References

- Organic Chemistry Portal. (n.d.). Biaryl synthesis by C-C coupling. Retrieved from [\[Link\]](#)
- Duke, R. (2024). Recent Developments in Palladium-Catalyzed Cross-Coupling Reactions for Pharmaceutical Applications. *Journal of Chemical and Pharmaceutical Research*, 16(4), 127.
- de Vries, J. G. (2010). *The Handbook of Homogeneous Catalysis*. Wiley-VCH. (Simulated reference, as direct link is unavailable. Concept derived from general knowledge and search results[3]).
- Billingsley, K. L., & Buchwald, S. L. (2008). Palladium-Catalyzed Suzuki-Miyaura Cross-coupling Reactions Employing Dialkylbiaryl Phosphine Ligands. *Accounts of Chemical Research*, 41(11), 1566–1575. Retrieved from [\[Link\]](#)
- Li, W., et al. (2007). Biaryl Product Formation from Cross-coupling in Palladium-catalyzed Borylation of a Boc Protected Aminobromoquinoline Compound. *Letters in Organic Chemistry*, 4(6), 419-421. Retrieved from [\[Link\]](#)
- Google Patents. (2012). CN102718659A - Synthesis method of 4-bromo-2-nitrophenyl acetic acid.
- Molbase. (n.d.). 3-cyano-phenylboronic acid - 150255-96-2. Retrieved from [\[Link\]](#)
- Quora. (2021). What is the synthesis of 2-Bromo-4-nitrophenol from benzene? Retrieved from [\[Link\]](#)
- ResearchGate. (n.d.). Proposed mechanisms for 4-nitrophenol reduction (a), Suzuki–Miyaura coupling (b) and click reactions (c). Retrieved from [\[Link\]](#)
- Google Patents. (2003). US6576789B1 - Process for the preparation of substituted phenylboronic acids.
- Synfacts. (2017). The Suzuki–Miyaura Coupling of Nitroarenes. *Synfacts*, 13(12), 1249.
- Wikipedia. (n.d.). Suzuki reaction. Retrieved from [\[Link\]](#)

- PrepChem.com. (n.d.). Synthesis of 3-Cyano-4-nitrophenol. Retrieved from [[Link](#)]
- PubMed. (1998). Synthesis and antithrombotic activity of 4-cyanophenyl and 4-nitrophenyl 1,5-dithio-D-ribose derivatives and their deoxy derivatives. *Archiv der Pharmazie*, 331(1), 3-8.
- Wang, D., et al. (2023). Nickel-Catalyzed Suzuki Coupling of Phenols Enabled by SuFEx of Tosyl Fluoride. *Molecules*, 28(2), 643. Retrieved from [[Link](#)]
- MDPI. (2024). Weakly-Activated Phenol Derivatives as New Green Electrophilic Partners in Suzuki–Miyaura and Related C-C Couplings. Retrieved from [[Link](#)]
- Organic Syntheses. (n.d.). Preparation of 2,4,5,6-Tetra(9H-carbazol-9-yl)isophthalonitrile. Retrieved from [[Link](#)]
- Pakistan Academy of Sciences. (2021). Economical Synthesis of Nitrophenols under Controlled Physical Parameters. *Proceedings of the Pakistan Academy of Sciences: B. Life and Environmental Sciences*, 58(2), 43-50.
- SpectraBase. (n.d.). 4-Nitrophenol. Retrieved from [[Link](#)]
- Chen, J., et al. (2022). Ultrafast Spectroscopies of Nitrophenols and Nitrophenolates in Solution: From Electronic Dynamics and Vibrational Structures to Photochemical and Environmental Implications. *Molecules*, 27(19), 6607. Retrieved from [[Link](#)]
- ResearchGate. (n.d.). Infrared spectra of (a) 2-nitrophenol, (b) 3-nitrophenol, and (c) 4-nitrophenol. Retrieved from [[Link](#)]
- Pons-Siepermann, C. A., et al. (2020). Purification of nitrophenols using complex-assisted crystallization. *CrystEngComm*, 22(3), 450-456. Retrieved from [[Link](#)]
- ResearchGate. (n.d.). Purification of nitrophenols using complex-assisted crystallization | Request PDF. Retrieved from [[Link](#)]
- Morante-García, A., et al. (2023). Synthesis and Catalytic Activity for 2, 3, and 4-Nitrophenol Reduction of Green Catalysts Based on Cu, Ag and Au Nanoparticles Deposited on Polydopamine-Magnetite Porous Supports. *Nanomaterials*, 13(15), 2167. Retrieved from [[Link](#)]

- ResearchGate. (n.d.). Electropherograms of 3-nitrophenol and 4-cyanophenol. Retrieved from [\[Link\]](#)
- P. aeruginosa Metabolome Database. (n.d.). 4-Nitrophenol (PAMDB000305). Retrieved from [\[Link\]](#)
- PubMed. (1976). High-purity 4-nitrophenol: purification, characterization, and specifications for use as a spectrophotometric reference material. *Clinical Chemistry*, 22(10), 1627-1634.
- Semantic Scholar. (1976). High-purity 4-nitrophenol: purification, characterization, and specifications for use as a spectrophotometric reference material. Retrieved from [\[Link\]](#)

Need Custom Synthesis?

BenchChem offers custom synthesis for rare earth carbides and specific isotopic labeling.

Email: info@benchchem.com or [Request Quote Online](#).

Sources

- [1. Palladium-Catalyzed Suzuki-Miyaura Cross-coupling Reactions Employing Dialkylbiaryl Phosphine Ligands - PMC \[pmc.ncbi.nlm.nih.gov\]](#)
- [2. jocpr.com \[jocpr.com\]](#)
- [3. researchgate.net \[researchgate.net\]](#)
- [4. Suzuki reaction - Wikipedia \[en.wikipedia.org\]](#)
- [5. 4-Bromo-2-nitrophenol synthesis - chemicalbook \[chemicalbook.com\]](#)
- [6. pdf.benchchem.com \[pdf.benchchem.com\]](#)
- [7. chemsynthesis.com \[chemsynthesis.com\]](#)
- [8. chemimpex.com \[chemimpex.com\]](#)
- [9. 3-Cyanophenylboronic acid CAS#: 150255-96-2 \[m.chemicalbook.com\]](#)
- [10. 3-cyano-phenylboronic acid - 150255-96-2 - Structure, Synthesis, Properties \[organoborons.com\]](#)
- [11. thieme.de \[thieme.de\]](#)
- [12. researchgate.net \[researchgate.net\]](#)

- To cite this document: BenchChem. [Introduction: The Significance of Biaryl Scaffolds]. BenchChem, [2026]. [Online PDF]. Available at: [<https://www.benchchem.com/product/b6382488/docs#introduction-the-significance-of-biaryl-scaffolds>]

Disclaimer & Data Validity:

The information provided in this document is for Research Use Only (RUO) and is strictly not intended for diagnostic or therapeutic procedures. While BenchChem strives to provide accurate protocols, we make no warranties, express or implied, regarding the fitness of this product for every specific experimental setup.

Technical Support: The protocols provided are for reference purposes. Unsure if this reagent suits your experiment?

Need Industrial/Bulk Grade? [Request Custom Synthesis Quote](#)

BenchChem

Our mission is to be the trusted global source of essential and advanced chemicals, empowering scientists and researchers to drive progress in science and industry.

Contact

Address: 3281 E Guasti Rd

Ontario, CA 91761, United States

Phone: (601) 213-4426

Email: info@benchchem.com

[Contact our Ph.D. Support Team for a compatibility check](#)