

experimental protocol for using 5-(4-Cyanophenyl)-2-hydroxypyridine

Author: BenchChem Technical Support Team. **Date:** April 2026

Compound of Interest

Compound Name: 5-(4-Cyanophenyl)-2-hydroxypyridine, 95%

CAS No.: 1111106-18-3

Cat. No.: B6365832

[Get Quote](#)

Technical Application Note: 5-(4-Cyanophenyl)-2-hydroxypyridine

Part 1: Core Directive & Chemical Identity[2]

Executive Summary

5-(4-Cyanophenyl)-2-hydroxypyridine (also known as 5-(4-Cyanophenyl)-2(1H)-pyridone) is a high-value biaryl scaffold used primarily in the synthesis of kinase inhibitors, GPCR ligands, and advanced material sciences (liquid crystals).[1][2] Structurally, it belongs to the class of 5-aryl-2-pyridones, a privileged motif in drug discovery that mimics the hydrogen-bonding patterns of nucleobases and peptide bonds.[1]

While structurally analogous to the core of the anti-epileptic drug Perampanel (Fycompa), this specific isomer (4-cyanophenyl at C5) serves as a distinct building block.[1] It offers a versatile platform for divergent synthesis: the pyridone nitrogen allows for pharmacokinetic modulation (solubility/permeability), while the C3-position is primed for regioselective functionalization.[1]

Chemical Properties & Tautomerism

Understanding the tautomeric equilibrium is critical for reaction planning. In the solid state and polar solvents (DMSO, DMF, MeOH), the compound exists predominantly as the 2-pyridone (lactam) form.^[1] In non-polar solvents or the gas phase, the 2-hydroxypyridine (lactim) form may contribute, but synthetic protocols generally target the amide-like reactivity of the pyridone.^[1]

Property	Specification
CAS Number	1198416-57-7 (Isomer Ref) / Generic 5-aryl-pyridone class
Molecular Formula	C ₁₂ H ₈ N ₂ O
Molecular Weight	196.21 g/mol
Solubility	High: DMSO, DMF, DMAc. ^{[1][2]} Moderate: MeOH, EtOH. ^[1] Low: Water, DCM, Hexanes. ^[1]
pKa	~11 (NH deprotonation)
Tautomer Preference	Lactam (Pyridone) is favored in solution (>95% in DMSO). ^[1]

Part 2: Experimental Protocols

Protocol A: Quality Control & Analytical Characterization

Objective: To validate purity and tautomeric state prior to synthetic use.

1. HPLC Method (Reverse Phase)

- Column: C18 (e.g., Agilent Zorbax Eclipse Plus, 3.5 μm, 4.6 x 100 mm).^[1]
- Mobile Phase A: Water + 0.1% Formic Acid.
- Mobile Phase B: Acetonitrile + 0.1% Formic Acid.
- Gradient: 5% B to 95% B over 10 min.

- Detection: UV at 254 nm (aromatic) and 280 nm (pyridone carbonyl).[1]
- Retention Time: Expect elution at ~6.5 min (mid-polar region due to nitrile/pyridone polarity).

2. NMR Validation (Tautomer Check)

- Solvent: DMSO-d₆.
- Diagnostic Signals:
 - δ 11.5–12.0 ppm (Broad Singlet): Indicates N-H of the pyridone form.[1] Absence of this peak and presence of a signal >13 ppm would suggest the O-H lactim (rare).[1]
 - δ 7.8–8.2 ppm: Doublets corresponding to the 4-cyanophenyl ring.

Protocol B: Synthetic Functionalization (N-Arylation)

Objective: To functionalize the pyridone nitrogen using Chan-Lam coupling.[1] This is superior to alkylation for introducing aromatic diversity without using toxic alkyl halides.[1]

Context: Direct N-arylation creates "drug-like" cores found in AMPA receptor antagonists and p38 MAP kinase inhibitors.

Reagents:

- Substrate: 5-(4-Cyanophenyl)-2-hydroxypyridine (1.0 equiv)
- Coupling Partner: Aryl Boronic Acid (e.g., Phenylboronic acid) (1.5 equiv)[1]
- Catalyst: Copper(II) Acetate [Cu(OAc)₂] (0.2–0.5 equiv)[1]
- Ligand: Pyridine or DMAP (2.0 equiv) - promotes coordination[1]
- Base: Cesium Carbonate (Cs₂CO₃) or Triethylamine (2.0 equiv)[1]
- Solvent: Dichloromethane (DCM) or 1,4-Dioxane (anhydrous)[1]
- Atmosphere: Oxygen (O₂) balloon or open air (oxidative coupling).[1]

Step-by-Step Workflow:

- Setup: In a dry round-bottom flask, charge the pyridone substrate (1.0 eq), Aryl Boronic Acid (1.5 eq), and Cu(OAc)₂ (0.2 eq).
- Solvation: Add anhydrous DCM (0.1 M concentration relative to substrate).
- Activation: Add Pyridine (2.0 eq) followed by Triethylamine (2.0 eq). The solution typically turns deep blue/green (active Cu-species).
- Reaction: Stir vigorously at room temperature (25°C) under an O₂ atmosphere (balloon) or open air with a drying tube.
 - Note: Reaction times vary from 12 to 48 hours. Monitor by HPLC (Protocol A).
- Workup:
 - Quench with aqueous NH₄Cl / NH₄OH (9:[1]1) to sequester copper (turns deep blue).[1]
 - Extract with DCM (3x).
 - Wash organic layer with brine, dry over Na₂SO₄, and concentrate.[1]
- Purification: Flash chromatography (SiO₂). Elute with Hexane/EtOAc (gradient 0–50%).

Protocol C: Regioselective C3-Bromination

Objective: To install a halogen handle at the C3 position (ortho to the carbonyl), enabling subsequent Suzuki couplings to form trisubstituted pyridines.[1]

Mechanism: The 2-pyridone ring is electron-rich.[1] Electrophilic aromatic substitution (SEAr) occurs preferentially at C3 and C5.[1] Since C5 is blocked by the cyanophenyl group, bromination occurs exclusively at C3.[1]

Reagents:

- Substrate: 5-(4-Cyanophenyl)-2-hydroxypyridine (or N-substituted derivative)
- Brominating Agent: N-Bromosuccinimide (NBS) (1.05 equiv)[1]

- Solvent: DMF or Acetonitrile (ACN)[1]
- Temperature: 0°C to Room Temperature.

Step-by-Step Workflow:

- Dissolution: Dissolve the substrate in DMF (0.2 M).
- Addition: Cool to 0°C. Add NBS portion-wise over 15 minutes to prevent over-reaction or exotherms.
- Reaction: Allow to warm to room temperature. Stir for 1–2 hours.
 - Checkpoint: TLC should show a less polar spot (monobromide).
- Quench: Pour the mixture into ice-water. The product often precipitates as a solid.
- Isolation: Filter the solid. Wash with water and cold MeOH.
- Yield: Typically >85%.

Part 3: Visualization & Logic

Tautomeric & Synthetic Logic Diagram

The following diagram illustrates the tautomeric equilibrium and the decision tree for functionalization.

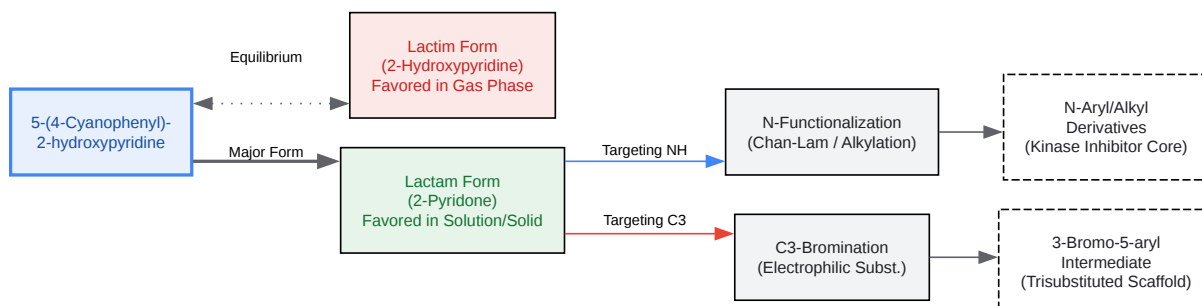

[Click to download full resolution via product page](#)

Caption: Tautomeric equilibrium favors the 2-pyridone (Lactam) form in solution, directing synthetic strategies toward N-functionalization or C3-electrophilic substitution.[1]

Part 4: References

- Suzuki-Miyaura Coupling Mechanism & Applications Title: Suzuki Coupling - Organic Chemistry Portal. Source: Organic Chemistry Portal.[3] URL:[[Link](#)]
- Tautomerism of 2-Pyridones Title: Tautomerism of Formamide, 2-Pyridone, and 4-Pyridone: An ab Initio Study. Source: Wayne State University / J. Phys. Chem. URL:[[Link](#)][1]
- Synthesis of Perampanel (Analogous Chemistry) Title: Process for the preparation of Perampanel. Source: Technical Disclosure Commons. URL:[[Link](#)][1]

Need Custom Synthesis?

BenchChem offers custom synthesis for rare earth carbides and specific isotopic labeling.

Email: info@benchchem.com or [Request Quote Online](#).

Sources

- 1. The Suzuki Reaction Applied to the Synthesis of Novel Pyrrolyl and Thiophenyl Indazoles - PMC [[pmc.ncbi.nlm.nih.gov](https://pubmed.ncbi.nlm.nih.gov/)]
- 2. 5-hydroxy-2-methyl pyridine, 1121-78-4 [[thegoodscentscompany.com](https://www.thegoodscentscompany.com/)]
- 3. Suzuki reaction - Wikipedia [en.wikipedia.org]
- To cite this document: BenchChem. [experimental protocol for using 5-(4-Cyanophenyl)-2-hydroxypyridine]. BenchChem, [2026]. [Online PDF]. Available at: [<https://www.benchchem.com/product/b6365832/docs#experimental-protocol-for-using-5-4-cyanophenyl-2-hydroxypyridine>]

Disclaimer & Data Validity:

The information provided in this document is for Research Use Only (RUO) and is strictly not intended for diagnostic or therapeutic procedures. While BenchChem strives to provide accurate protocols, we make no warranties, express or implied, regarding the fitness of this product for every specific experimental setup.

Technical Support: The protocols provided are for reference purposes. Unsure if this reagent suits your experiment?

Need Industrial/Bulk Grade? [Request Custom Synthesis Quote](#)

BenchChem

Our mission is to be the trusted global source of essential and advanced chemicals, empowering scientists and researchers to drive progress in science and industry.

Contact

Address: 3281 E Guasti Rd
Ontario, CA 91761, United States
Phone: (601) 213-4426
Email: info@benchchem.com

[Contact our Ph.D. Support Team for a compatibility check](#)