

Application Note: Cyanophenylpyridines as Functional Scaffolds in Optoelectronics and Sensing

Author: BenchChem Technical Support Team. **Date:** April 2026

Compound of Interest

Compound Name:	5-(4-Cyanophenyl)-2-hydroxypyridine, 95%
CAS No.:	1111106-18-3
Cat. No.:	B6365832

[Get Quote](#)

Introduction & Molecular Architecture

Cyanophenylpyridines represent a class of "push-pull" or electron-deficient molecular scaffolds critical to the advancement of Organic Light Emitting Diodes (OLEDs) and stimuli-responsive sensors. The molecular architecture combines a pyridine ring (electron-deficient acceptor) with a phenyl ring substituted by a cyano group (strong electron-withdrawing group).

Key Functional Advantages:

- **Deep LUMO Levels:** The synergistic electron-withdrawing nature of the pyridine nitrogen and the cyano group significantly stabilizes the Lowest Unoccupied Molecular Orbital (LUMO). This makes these derivatives excellent Electron Transport Materials (ETMs).
- **Tunable Phosphorescence:** When cyclometalated with Iridium(III), the cyano group alters the metal-to-ligand charge transfer (MLCT) energy, allowing for precise color tuning (from green to deep blue or red depending on regiochemistry).

- Mechanochromism: Many derivatives exhibit Aggregation-Induced Emission (AIE) or mechanochromic luminescence, switching emission color upon physical grinding due to transitions between crystalline and amorphous states.[1]

Application in Phosphorescent OLEDs (PhOLEDs) [2][3][4]

The primary application of cyanophenylpyridines is as the cyclometalating ligand in Iridium(III) complexes. Unlike the standard 2-phenylpyridine (ppy), the addition of a cyano group allows for fine-tuning of the triplet energy state.

Mechanism of Action

In Ir(III) complexes, emission arises from a mix of

MLCT and

LC (Ligand Centered) states.

- Regiochemical Control: Placing the -CN group at the 4-position of the phenyl ring stabilizes the HOMO (localized on the metal/phenyl) more than the LUMO, often resulting in a blue shift (high energy). Conversely, substitution patterns that stabilize the LUMO preferentially can induce red shifts.
- Efficiency: The strong ligand field prevents thermal population of non-emissive metal-centered (MC) states, ensuring high quantum efficiency ().

Protocol 1: Synthesis of the Ligand (2-(4-cyanophenyl)pyridine)

A robust Suzuki-Miyaura coupling protocol.

Reagents:

- 2-Bromopyridine (1.0 eq)

- 4-Cyanophenylboronic acid (1.1 eq)
- Tetrakis(triphenylphosphine)palladium(0) [Pd(PPh₃)₄] (5 mol%)
- Potassium Carbonate (K₂CO₃) (2 M aqueous solution)
- Solvent: 1,2-Dimethoxyethane (DME) or THF.

Step-by-Step Methodology:

- Degassing (Critical): Charge a Schlenk flask with DME and 2M K₂CO₃. Freeze-pump-thaw (3 cycles) to remove oxygen. Reasoning: Oxygen poisons the Pd(0) catalyst and promotes homocoupling.
- Reaction Assembly: Under Argon flow, add 2-Bromopyridine, 4-Cyanophenylboronic acid, and Pd(PPh₃)₄.
- Reflux: Heat the mixture to 85°C for 24 hours. The solution should turn from yellow to dark orange/brown.
- Work-up: Cool to RT. Extract with Dichloromethane (DCM) x3. Wash combined organics with brine. Dry over MgSO₄.

- Purification: Flash column chromatography (Silica gel). Eluent: Hexane/Ethyl Acetate (gradient 10:1 to 5:1).

- Validation:

H NMR should show the diagnostic doublet of the phenyl ring shifted downfield due to the -CN group.

Protocol 2: Synthesis of the Heteroleptic Ir(III) Complex

Target: Ir(cn-ppy)

(acac)

Step-by-Step Methodology:

- Dimer Formation:

- Mix IrCl

[2]·nH

O and Ligand (2.2 eq) in 2-ethoxyethanol/water (3:1).

- Reflux at 110°C for 24h under N

.

- Observation: A yellow/orange precipitate (the chloro-bridged dimer) forms.

- Filter and wash with water and methanol.

- Complexation:

- Suspend the dimer in 2-ethoxyethanol.

- Add Acetylacetonone (acac) (2.5 eq) and Na

CO

(5 eq).

- Reflux at 100°C for 12h.
- Purification:
 - Cool and filter. The product is often soluble in DCM.
 - Recrystallize from DCM/Hexane. Sublimation is required for OLED-grade purity (>99.9%).

Visualization: Synthesis Workflow

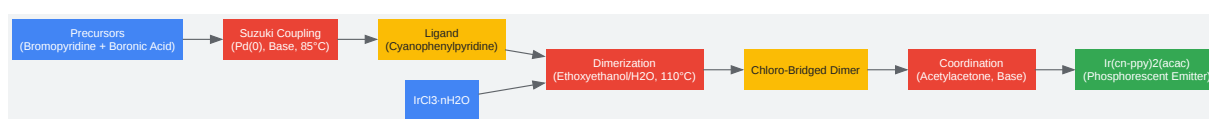

[Click to download full resolution via product page](#)

Figure 1: Synthetic pathway for high-purity Iridium(III) cyanophenylpyridine complexes.

Application as Electron Transport Materials (ETMs)

[3][6][7]

Due to the high electron affinity of the pyridine-cyano combination, these molecules are ideal for the Electron Transport Layer (ETL) in OLED stacks. They facilitate electron injection from the cathode and block holes from escaping the Emissive Layer (EML).

Comparative Data: Standard vs. Cyanophenylpyridine ETMs

Property	Alq (Standard)	Cyanophenylpyridine Derivative (e.g., TmPyPB)	Benefit
HOMO (eV)	-5.7	-6.2 to -6.5	Better Hole Blocking (Deep HOMO)
LUMO (eV)	-3.0	-3.2 to -3.5	Lower Injection Barrier (Matches Cathode)
Electron Mobility (cm ² /Vs)	~10	~100	Faster transport, lower driving voltage
Triplet Energy (T)	~2.0 eV	> 2.7 eV	Prevents exciton quenching in Blue/Green PhOLEDs

Visualization: OLED Device Architecture & Energy Alignment

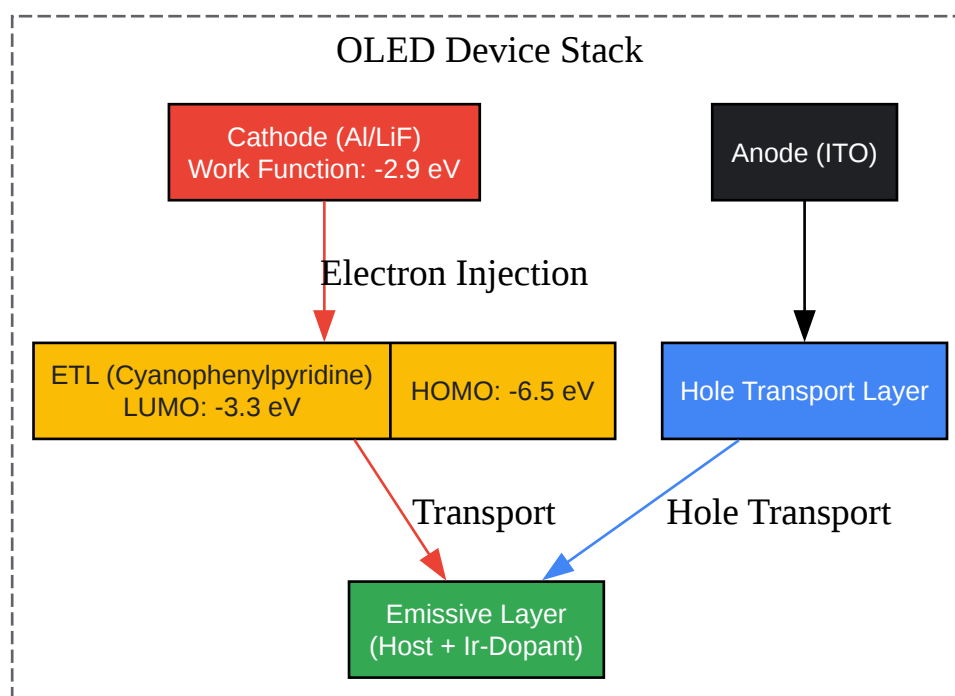

[Click to download full resolution via product page](#)

Figure 2: Role of Cyanophenylpyridine in OLED stack. Note the deep HOMO blocking holes from the HTL.

Mechanochromism & Sensing Protocols[1][8][9]

Cyanophenylpyridines often exhibit Mechanochromic Luminescence (MCL). In the crystalline state, molecules are packed tightly (often via

-

stacking or CN

H interactions), resulting in a specific emission color. Mechanical grinding disrupts this packing, forming an amorphous state with a red-shifted emission.

Applications:

- Stress Sensors: Visualizing mechanical fatigue in polymers.
- Security Inks: Data storage that can be written by pressure and erased by heat.
- Bio-Imaging: Used as AIE (Aggregation Induced Emission) probes to detect cellular viscosity or aggregation.

Protocol 3: Mechanochromic Screening

Objective: Determine the MCL contrast and reversibility.

- Pristine Sample: Synthesize the cyanophenylpyridine derivative. Recrystallize to ensure a thermodynamic crystalline state. Measure Fluorescence ().
- Grinding (Amorphization): Place 50 mg of sample in an agate mortar. Grind vigorously for 5 minutes.
 - Visual Check: Under 365 nm UV lamp, the color should shift (e.g., Blue

Yellow).

- Measurement: Measure Fluorescence ().
- Fuming (Reversibility): Expose the ground powder to solvent vapor (DCM or Acetone) for 60 seconds OR heat to 150°C.
 - Result: The emission should revert to .
- Quantification: Calculate the spectral shift . A shift nm indicates high-contrast MCL suitable for sensor applications.

References

- OLED Emitter Tuning
 - Title: Structures of the cyanophenylpyridines and their computationally predicted reduction potentials.
 - Source: ResearchGate / J.
 - URL:[\[Link\]](#)
- Mechanochromic Mechanisms
 - Title: Enabling Peculiar Photophysics and Mechanochromic Luminescence by Introducing Bromine in Push–Pull Pyridine Deriv
 - Source: ResearchG
 - URL:[\[Link\]](#)
- Electron Transport Materials (General Pyridine/Triazole Context)

- Title: Pyridine-based electron transporting materials for highly efficient organic solar cells. [3]
- Source: ResearchG
- URL:[[Link](#)]
- Iridium Complex Synthesis Protocol Basis
 - Title: Synthesis and photoluminescence of iridium(iii) arylacetylide complexes.[4]
 - Source: NIH / PubMed Central.
 - URL:[[Link](#)]

Need Custom Synthesis?

BenchChem offers custom synthesis for rare earth carbides and specific isotopic labeling.

Email: info@benchchem.com or [Request Quote Online](#).

Sources

- [1. researchgate.net \[researchgate.net\]](https://www.researchgate.net)
- [2. CN1269827C - Method for synthesizing iridium \(III\) triacetylacetonate - Google Patents \[patents.google.com\]](https://patents.google.com/patent/CN1269827C)
- [3. pdfs.semanticscholar.org \[pdfs.semanticscholar.org\]](https://pdfs.semanticscholar.org)
- [4. Synthesis and photoluminescence of iridium\(iii\) arylacetylide complexes with acetylide-localized emissive excited states - PMC \[pmc.ncbi.nlm.nih.gov\]](https://pubmed.ncbi.nlm.nih.gov/20111111/)
- To cite this document: BenchChem. [Application Note: Cyanophenylpyridines as Functional Scaffolds in Optoelectronics and Sensing]. BenchChem, [2026]. [Online PDF]. Available at: [<https://www.benchchem.com/product/b6365832/docs#application-note-cyanophenylpyridines-as-functional-scaffolds-in-optoelectronics-and-sensing>]

Disclaimer & Data Validity:

The information provided in this document is for Research Use Only (RUO) and is strictly not intended for diagnostic or therapeutic procedures. While BenchChem strives to provide accurate protocols, we make no warranties, express or implied, regarding the fitness of this product for every specific experimental setup.

Technical Support: The protocols provided are for reference purposes. Unsure if this reagent suits your experiment?

Need Industrial/Bulk Grade? [Request Custom Synthesis Quote](#)

BenchChem

Our mission is to be the trusted global source of essential and advanced chemicals, empowering scientists and researchers to drive progress in science and industry.

Contact

Address: 3281 E Guasti Rd
Ontario, CA 91761, United States
Phone: (601) 213-4426
Email: info@benchchem.com

[Contact our Ph.D. Support Team for a compatibility check](#)