

# 1H NMR characterization of paramagnetic Ni(bpy)I<sub>2</sub>

**Author:** BenchChem Technical Support Team. **Date:** May 2026

## Compound of Interest

Compound Name: (2,2'-Bipyridine)diiodonickel

CAS No.: 59448-25-8

Cat. No.: B6359968

[Get Quote](#)

This guide details the technical workflow for characterizing Nickel(II) (2,2'-bipyridine) diiodide [Ni(bpy)I<sub>2</sub>],

a paramagnetic complex widely used in cross-coupling catalysis and electrochemical studies.

Unlike standard organic intermediates, Ni(bpy)I<sub>2</sub>

possesses a

electronic configuration with a triplet ground state (

) in most coordination geometries (tetrahedral or solvated octahedral). This paramagnetism renders standard 1H NMR protocols useless, resulting in "silent" spectra or misleading baselines. This guide compares the standard "blind" approach against the optimized Paramagnetic Protocol and validates the electronic state using the Evans Method.

## Part 1: The Characterization Challenge

The core challenge lies in the interaction between the unpaired electrons of the Ni(II) center and the ligand nuclei. This interaction occurs via two mechanisms:

- Contact Shift (Fermi Contact): Delocalization of unpaired spin density through the  
and  
bond network onto the bipyridine protons.
- Pseudocontact Shift (Dipolar): Through-space magnetic coupling.

Impact on NMR:

- Chemical Shift Dispersion: Signals shift hundreds of ppm outside the standard 0–12 ppm window.
- Relaxation Enhancement: The paramagnetic center drastically shortens  
and  
relaxation times, causing extreme line broadening (  
Hz).

## Workflow Visualization

The following diagram outlines the decision logic for characterizing this paramagnetic species.

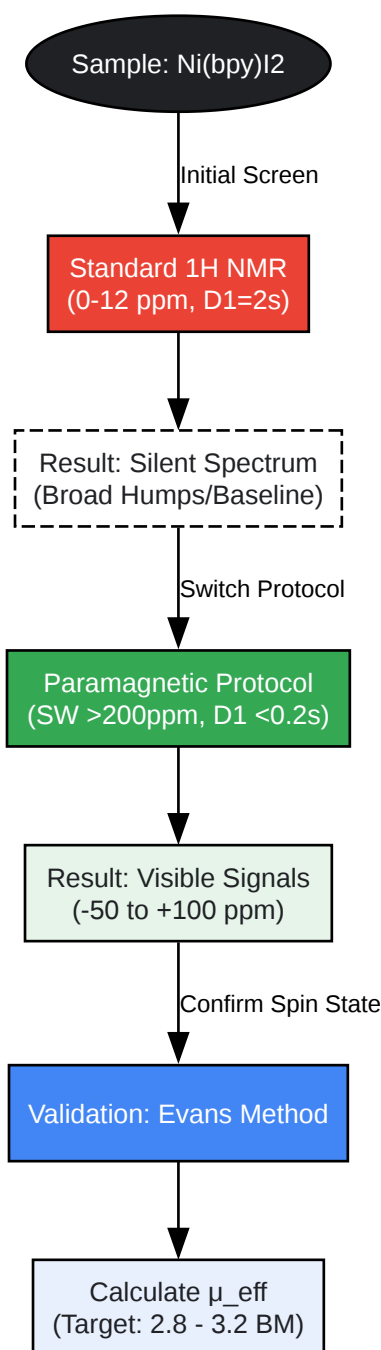

[Click to download full resolution via product page](#)

Figure 1: Decision logic for transitioning from standard to paramagnetic NMR protocols.

## Part 2: Comparative Analysis of Methods

This section compares the "Standard" approach (often attempted by researchers familiar only with diamagnetic organics) versus the "Optimized Paramagnetic" approach.

**Table 1: Performance Comparison of NMR Protocols**

Feature	Standard Protocol (The Alternative)	Paramagnetic Protocol (The Solution)	Technical Rationale
Spectral Width (SW)	12 ppm (0 to 12 ppm)	200–400 ppm (-100 to +300 ppm)	Paramagnetic hyperfine shifts can displace signals by >100 ppm.
Relaxation Delay (D1)	1.0 – 5.0 seconds	0.01 – 0.1 seconds	Paramagnetic relaxation ( ) is extremely fast (<10 ms); long delays waste time.
Acquisition Time (AQ)	2.0 – 4.0 seconds	0.05 – 0.2 seconds	Signal decays rapidly; acquiring noise after the FID prevents S/N improvement.
Pulse Angle	30° – 45°	90°	Fast relaxation allows for maximizing signal per scan without saturation.
Line Broadening (LB)	0.3 Hz	10 – 50 Hz	Matched filtration: LB should match the natural linewidth (often >50 Hz) to maximize S/N.
Result	"Empty" spectrum or broad baseline humps.	Broad but distinct resonances for protons.	Allows confirmation of ligand coordination and symmetry.

## Part 3: Detailed Characterization Protocols

## Protocol A: Optimized Paramagnetic $^1\text{H}$ NMR

Objective: Visualize the bipyridine ligand protons attached to the Ni(II) center.

- Sample Preparation:
  - Dissolve 10–15 mg of Ni(bpy) $_2$  in 0.6 mL of deuterated solvent ( $\text{CDCl}_3$  or  $\text{DMSO-}d_6$  are preferred for solubility;  $\text{CDCl}_3$  often yields poor solubility).
  - Note: Ensure the solution is free of suspended solids. Filter if necessary.
- Instrument Setup:
  - Lock/Shim: Lock on the solvent. Shim on the solvent peak (the only narrow signal). Do not try to shim on the sample peaks.
  - Center Frequency (O1P): Set to  $\sim 50$  ppm (midpoint of expected range).
  - Sweep Width (SW): Set to at least 250 ppm (approx -50 to +200 ppm).
  - Acquisition Time (AQ): Reduce to  $\sim 0.1$  s.
  - Relaxation Delay (D1): Set to 10 ms (0.01 s).
  - Scans (NS): 1024 – 4096 scans (broad signals require high S/N).
- Processing:
  - Apply exponential multiplication (EM) with LB = 20 Hz.
  - Phase correction must be done manually; automated routines often fail on broad peaks.
  - Baseline correction (Bernstein polynomial) is critical to flatten the wide baseline.

Expected Data: Unlike free bipyridine (signals at 7–9 ppm), Ni(bpy)I

will show broad resonances shifted significantly. Based on literature for Ni(II)-bpy systems:

- H-3,3' (Ortho to N): Typically shifted upfield (negative ppm) or very far downfield depending on the contact mechanism (

vs

). In many Ni(II) systems, these appear near -10 to -60 ppm.

- H-4,4' / H-5,5': Often found in the +40 to +100 ppm range.
- Interpretation: The observation of these shifted peaks confirms the ligand is bound to a paramagnetic center. If only 7–9 ppm peaks are seen, the ligand is free (dissociated).

## Protocol B: The Evans Method (Validation)

Objective: Determine the magnetic moment (

) to confirm the high-spin (

) state and purity.

- Insert Preparation:
  - Inner Tube: Capillary containing pure solvent + reference standard (e.g., 5% t-Butanol in CD  
CN).
  - Outer Tube: Ni(bpy)I  
solution + same reference standard (5% t-Butanol in CD  
CN).
- Measurement:
  - Run a standard proton spectrum.

- Focus on the t-Butanol methyl singlet. You will see two peaks:
  - Peak A (Inner): Unshifted (diamagnetic environment).
  - Peak B (Outer): Shifted ( ) due to the bulk magnetic susceptibility of the paramagnetic Ni(II).
- Calculation: Use the Evans equation (for superconducting magnets):
  - : Shift difference in Hz.
  - : Spectrometer frequency in Hz.[1][2]
  - : Concentration in mol/mL.
  - Target Value: For Ni(bpy)I (High Spin , ), expected .

## Part 4: Data Interpretation & Troubleshooting

### Table 2: Comparison of Chemical Shifts

Proton Environment	Free Ligand (Diamagnetic)	Ni(bpy)I (Paramagnetic)	Observation Notes
H-3,3'	~8.5 ppm (Doublet)	-20 to -60 ppm (Broad Singlet)	Strong contact shift due to proximity to N-Ni bond.
H-4,4'	~7.8 ppm (Triplet)	+10 to +50 ppm (Broad Singlet)	Shift direction depends on -spin density sign.
H-5,5'	~7.3 ppm (Triplet)	-10 to -40 ppm (Broad Singlet)	Alternating shift pattern is characteristic of -delocalization.
H-6,6'	~8.7 ppm (Doublet)	Obscured / Very Broad	Often too close to the metal (fast relaxation) to be easily observed.

Note: Exact shift values depend heavily on solvent (e.g., MeCN vs DMSO) and temperature.

## Common Pitfalls

- "I see peaks at 7-8 ppm."
  - Diagnosis: Ligand dissociation.[2] The complex may have fallen apart in the solvent, or the sample is primarily free ligand.
- "I see nothing."
  - Diagnosis: SW is too narrow. Expand to 400 ppm. Alternatively, the concentration is too low (paramagnetic signals are broad and short).
- "The peaks are too broad."

- Diagnosis: This is normal. Do not try to shim the sample peaks. Ensure the solvent peak is sharp.

## References

- Synthesis and <sup>1</sup>H NMR studies of paramagnetic nickel(II) complexes containing bis(pyrazolyl)methane ligands. Dalton Transactions, 2006.
- Two-Dimensional <sup>1</sup>H NMR Studies on Octahedral Nickel(II) Complexes. Inorganic Chemistry, 2000.
- An investigation of the <sup>1</sup>H NMR isotropic shifts for some methyl-substituted bipyridine complexes with Ni(II). Canadian Journal of Chemistry, 1981.
- Magnetic Susceptibility of Coordination Compounds (Evans Method Protocol). Chemistry LibreTexts.

### Need Custom Synthesis?

BenchChem offers custom synthesis for rare earth carbides and specific isotopic labeling.

Email: [info@benchchem.com](mailto:info@benchchem.com) or [Request Quote Online](#).

## Sources

- [1. measurement.sk \[measurement.sk\]](#)
- [2. rsc.org \[rsc.org\]](#)
- To cite this document: BenchChem. [1H NMR characterization of paramagnetic Ni(bpy)I2]. BenchChem, [2026]. [Online PDF]. Available at: [\[https://www.benchchem.com/product/b6359968/docs#1h-nmr-characterization-of-paramagnetic-ni-bpy-i2\]](https://www.benchchem.com/product/b6359968/docs#1h-nmr-characterization-of-paramagnetic-ni-bpy-i2)

---

### Disclaimer & Data Validity:

The information provided in this document is for Research Use Only (RUO) and is strictly not intended for diagnostic or therapeutic procedures. While BenchChem strives to provide

accurate protocols, we make no warranties, express or implied, regarding the fitness of this product for every specific experimental setup.

**Technical Support:** The protocols provided are for reference purposes. Unsure if this reagent suits your experiment?

**Need Industrial/Bulk Grade?** [Request Custom Synthesis Quote](#)

## BenchChem

Our mission is to be the trusted global source of essential and advanced chemicals, empowering scientists and researchers to drive progress in science and industry.

### Contact

Address: 3281 E Guasti Rd

Ontario, CA 91761, United States

Phone: (601) 213-4426

Email: [info@benchchem.com](mailto:info@benchchem.com)

[Contact our Ph.D. Support Team for a compatibility check](#)