

# Challenges in the development of indazole-based drugs.

**Author:** BenchChem Technical Support Team. **Date:** April 2026

## Compound of Interest

Compound Name: 7-Methoxy-4,5-dihydro-1H-benzo[g]indazole

CAS No.: 501936-07-8

Cat. No.: B6351529

[Get Quote](#)

Welcome to the Indazole Technical Support Center.

Current Status: Online Operator: Dr. A. Vance, Senior Application Scientist Ticket ID: INDZ-DEV-2026

## Overview: The Indazole Paradox

The indazole scaffold is a "privileged structure" in medicinal chemistry, serving as the core for blockbuster kinase inhibitors like Axitinib and Pazopanib [1].[1] However, its utility is often bottlenecked by two distinct challenges: synthetic regioselectivity (the N1 vs. N2 alkylation struggle) and physicochemical "brick dust" properties (poor solubility due to planar -stacking).

This guide bypasses general theory to address the specific failure points encountered in the lab.

## Module 1: Synthetic Chemistry – Troubleshooting N-Alkylation

The Issue: You are attempting to alkylate a 1H-indazole and are receiving a mixture of N1- and N2-alkylated products, or predominantly the unwanted N2-isomer.

The Mechanism (Causality): Indazole anions are ambident nucleophiles.

- N1-Alkylation (Thermodynamic): The N1-substituted product preserves the benzenoid aromaticity of the fused ring system, making it thermodynamically more stable (~2-4 kcal/mol lower energy than N2).
- N2-Alkylation (Kinetic): The lone pair on N2 is often more accessible sterically and electronically (highest HOMO coefficient), leading to faster reaction rates under kinetic control [2].

### Diagnostic Workflow

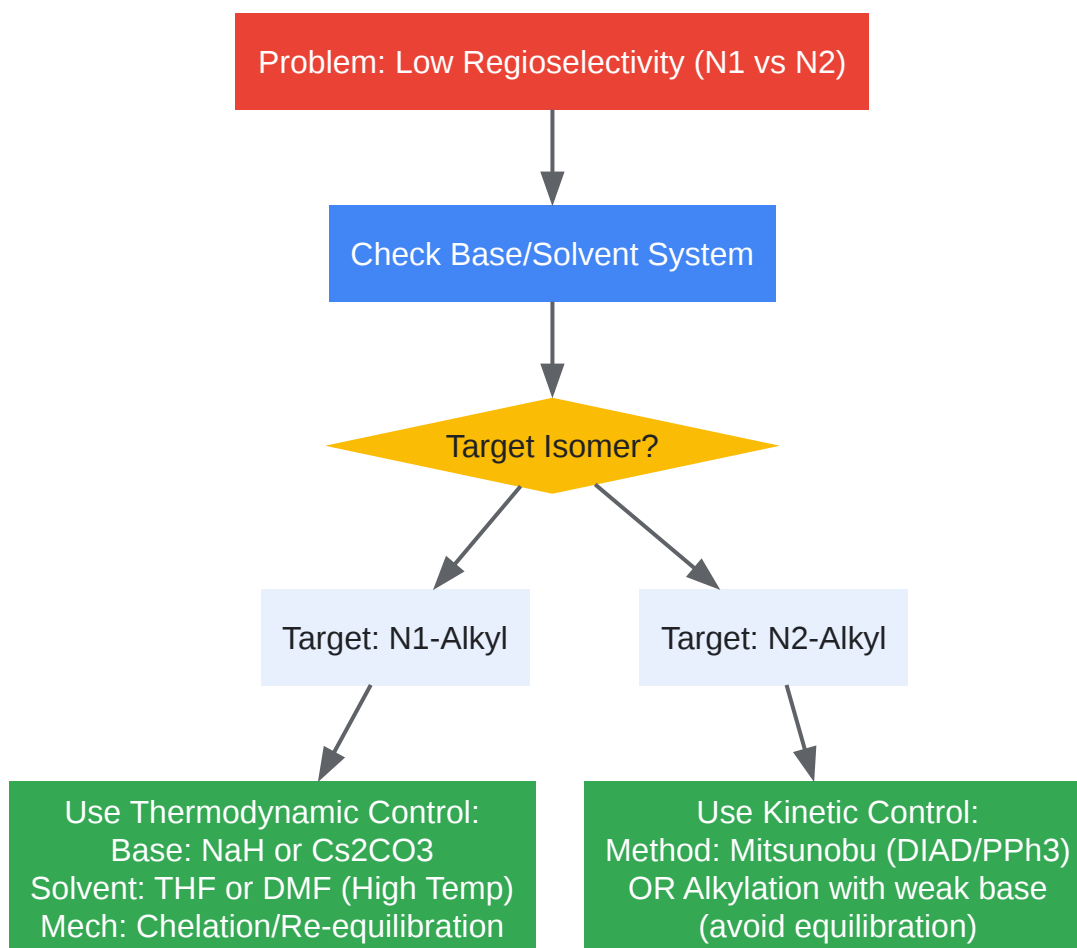

[Click to download full resolution via product page](#)

Figure 1: Decision tree for selecting reaction conditions based on the desired regioisomer.

## FAQ: Specific Scenarios

Q: I used  $K_2CO_3$  in DMF, but I'm still getting 30% N2 product. How do I push this to N1? A: Potassium carbonate is often too weak to ensure full thermodynamic equilibration at room temperature.

- Solution: Switch to NaH (Sodium Hydride) in THF. The sodium cation can coordinate with the N2 and the C3-substituent (if present), directing alkylation to N1 via a "chelation-controlled" mechanism.[2] Alternatively, heat the  $Cs_2CO_3$ /DMF reaction to  $>80^\circ C$  to overcome the activation energy barrier for rearrangement [2].

Q: I specifically need the N2-isomer for a bioisostere study. A: Do not use alkyl halides.

- Solution: Use Mitsunobu conditions (Alcohol + PPh<sub>3</sub> + DIAD). The Mitsunobu reaction typically favors the N2-isomer because the steric bulk of the betaine intermediate prevents attack at the more hindered N1 position, and the reaction is kinetically controlled [5].

## Standard Operating Procedure: N1-Selective Alkylation

Validated for 3-substituted indazoles.

- Dissolution: Dissolve 1H-indazole (1.0 eq) in anhydrous THF (0.1 M).
- Deprotonation: Cool to 0°C. Add NaH (1.2 eq, 60% dispersion) portion-wise.
- Equilibration (Critical Step): Stir for 30 minutes at Room Temp (RT). This allows the anion to stabilize.
- Addition: Add alkyl halide (1.1 eq) dropwise.
- Monitoring: Stir at RT. If N2 forms, heat to 60°C to force rearrangement to N1.

## Module 2: Physicochemical Optimization (Solubility)

The Issue: Your lead compound has nanomolar potency but precipitates in cellular assays (RPMI + 10% FBS) or shows <1% oral bioavailability.

The Mechanism: Indazoles are flat, aromatic systems. They stack efficiently in the solid state (high lattice energy), leading to the "Brick Dust" effect. High planarity correlates with low aqueous solubility.

### Data: Substituent Effects on Solubility

Modification Strategy	Chemical Change	Impact on Solubility	Mechanistic Rationale
Planarity Disruption	Phenyl Piperidine/Morpholine	High Increase (++++)	Introduces sp <sup>3</sup> character ("Fsp <sup>3</sup> "), disrupting crystal lattice packing.
Polar Surface Area	C-H N (Pyridine/Pyrimidine)	Moderate Increase (++)	Lowers LogP; H-bond acceptor capability increases solvation.
Solubilizing Groups	Add Morpholine/Piperazine tail	High Increase (+++)	Ionizable center (basic amine) allows salt formation at physiological pH.
N-Methylation	N-H N-Me	Variable (+/-)	Removes H-bond donor (bad for solubility) but disrupts symmetry (good).

## Troubleshooting Protocol: The "Solubility Rescue"

If your indazole core is fixed (e.g., for hinge binding), you must modify the periphery:

- The "Gatekeeper" Vector: In kinase inhibitors, the substituent pointing toward the solvent front (usually C3 or C5) is the best place to add solubilizing groups.
- Introduce Asymmetry: Symmetrical indazoles crystallize too well. Move a substituent from para to meta or ortho on an attached phenyl ring to lower the melting point.
- Formulation Patch: If you cannot change the chemistry, use Hydroxypropyl-β-cyclodextrin (HP-β-CD) in your vehicle. Indazoles fit well into the hydrophobic cavity of cyclodextrins, preventing precipitation [6].

## Module 3: Biological Selectivity & Metabolism[3][4][5][6][7][8]

The Issue: The compound hits the target kinase but also inhibits CYP450 enzymes or shows rapid clearance.

The Mechanism:

- Promiscuity: The indazole N-H and N2 mimic the Adenine N1 and N6 of ATP. Without specific "gatekeeper" interactions, they will bind to hundreds of kinases (The "Promiscuity Problem").
- Metabolism: The electron-rich benzene ring of the indazole is prone to oxidation.

### Signaling Pathway: Kinase Hinge Binding[1][4]

The diagram below illustrates the critical H-bond network required for high-affinity binding.

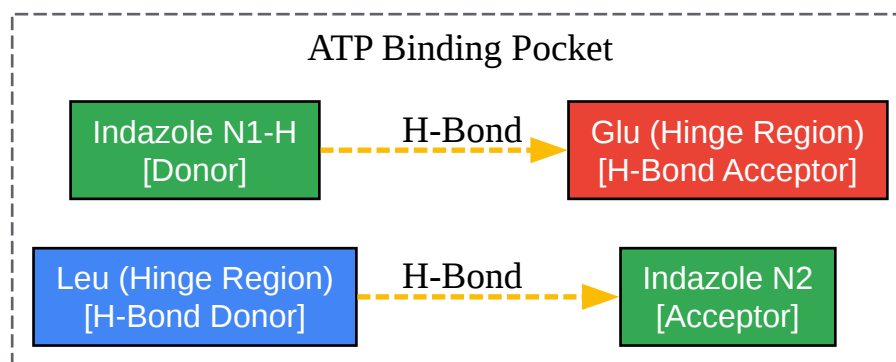

[Click to download full resolution via product page](#)

Figure 2: Canonical Type I binding mode of Indazole inhibitors at the kinase hinge region.

### FAQ: Improving Metabolic Stability

Q: My compound has a half-life (

) of <15 mins in liver microsomes. Where is the metabolic soft spot? A: It is likely the C3-position or the benzene ring (C4-C7).

- Solution 1 (Block C3): If C3 is a hydrogen or a methyl group, it is a prime site for CYP-mediated oxidation. Substitute C3 with an electron-withdrawing group (e.g., -CF<sub>3</sub>, -Cl) or a bulky group to block access [3].
- Solution 2 (Fluorination): Fluorinate the benzene ring (C5 or C6) to block arene oxidation. This is a tactic used in Pazopanib (which has a methylated indazole) to manage stability [1].

Q: How do I improve selectivity against other kinases? A: Target the Gatekeeper Residue. Most kinases have a specific amino acid at the entry to the hydrophobic pocket (the gatekeeper). Indazoles are small. By adding a bulky substituent at C3, you can clash with the gatekeeper of off-target kinases (if they have a large gatekeeper like Methionine) while fitting into targets with small gatekeepers (like Threonine) [4].

## References

- BenchChem. (2025).[3][4] Literature review on the discovery of indazole-containing compounds. [Link](#)
- University College Cork. (2021). Regioselective N-alkylation of the 1H-indazole scaffold. [Link](#)
- National Institutes of Health (PMC). (2021).[5] Metabolism-Guided Selective Androgen Receptor Antagonists. [Link](#)
- J-Stage. (2014). 7-Azaindole: A Versatile Scaffold for Developing Kinase Inhibitors. [Link](#)
- BenchChem. (2025).[4] Technical Support Center: Regioselectivity in Indazole N-Alkylation. [Link](#)
- Contract Pharma. (2017). Optimizing Drug Solubility. [Link](#)

### Need Custom Synthesis?

BenchChem offers custom synthesis for rare earth carbides and specific isotopic labeling.

Email: [info@benchchem.com](mailto:info@benchchem.com) or [Request Quote Online](#).

## Sources

- [1. pdf.benchchem.com \[pdf.benchchem.com\]](#)
- [2. BJOC - Regioselective alkylation of a versatile indazole: Electrophile scope and mechanistic insights from density functional theory calculations \[beilstein-journals.org\]](#)
- [3. benchchem.com \[benchchem.com\]](#)
- [4. pdf.benchchem.com \[pdf.benchchem.com\]](#)
- [5. ascendiadmo.com \[ascendiadmo.com\]](#)
- To cite this document: BenchChem. [Challenges in the development of indazole-based drugs.]. BenchChem, [2026]. [Online PDF]. Available at: [\[https://www.benchchem.com/product/b6351529/docs#challenges-in-the-development-of-indazole-based-drugs\]](https://www.benchchem.com/product/b6351529/docs#challenges-in-the-development-of-indazole-based-drugs)

---

### Disclaimer & Data Validity:

The information provided in this document is for Research Use Only (RUO) and is strictly not intended for diagnostic or therapeutic procedures. While BenchChem strives to provide accurate protocols, we make no warranties, express or implied, regarding the fitness of this product for every specific experimental setup.

**Technical Support:** The protocols provided are for reference purposes. Unsure if this reagent suits your experiment?

**Need Industrial/Bulk Grade?** [Request Custom Synthesis Quote](#)

## BenchChem

Our mission is to be the trusted global source of essential and advanced chemicals, empowering scientists and researchers to drive progress in science and industry.

### Contact

Address: 3281 E Guasti Rd

Ontario, CA 91761, United States

Phone: (601) 213-4426

Email: [info@benchchem.com](mailto:info@benchchem.com)

Contact our Ph.D. Support Team for a compatibility check