

physicochemical properties of 4-Chloro-2-fluoro-6-iodophenol

Author: BenchChem Technical Support Team. **Date:** April 2026

Compound of Interest

Compound Name: 4-Chloro-2-fluoro-6-iodophenol

CAS No.: 1192815-08-9

Cat. No.: B6341347

[Get Quote](#)

Technical Whitepaper: 4-Chloro-2-fluoro-6-iodophenol

Strategic Halogenation Scaffolds in Medicinal Chemistry

Executive Summary

4-Chloro-2-fluoro-6-iodophenol (CAS: 1192815-08-9) represents a high-value "tri-halogenated" scaffold. Its utility lies in the distinct reactivity profiles of its three halogen substituents: the lability of the ortho-iodine for cross-coupling, the metabolic blocking capability of the para-chlorine, and the electronic modulation provided by the ortho-fluorine. This guide analyzes its molecular architecture, predicted and observed physicochemical properties, and standardized protocols for its synthesis and validation.^[1]

Molecular Architecture & Electronic Effects

The molecule features a phenol core substituted at the 2, 4, and 6 positions.^[2] This specific substitution pattern creates a "push-pull" electronic environment that stabilizes the phenoxide

anion while enabling regioselective functionalization.

Structural Logic

- Position 1 (-OH): The hydroxyl group acts as an anchor for hydrogen bonding. The acidity is significantly enhanced by the electron-withdrawing nature of the ortho-F and para-Cl.
- Position 2 (-F): Fluorine exerts a strong inductive withdrawing effect (-I), increasing the acidity of the phenol. Additionally, it can function as a weak hydrogen bond acceptor, potentially forming an intramolecular bond with the hydroxyl proton, which influences membrane permeability.
- Position 4 (-Cl): Chlorine at the para position primarily serves to increase lipophilicity and block metabolic oxidation (CYP450-mediated hydroxylation) at the most reactive site of the phenol ring.
- Position 6 (-I): Iodine is the largest and most polarizable substituent. It provides a "reactive handle" for palladium-catalyzed cross-coupling reactions (Suzuki-Miyaura, Sonogashira) without interfering with the C-F or C-Cl bonds.

Visualizing the Structure-Activity Relationship (SAR)

The following diagram illustrates the functional role of each substituent in a drug discovery context.

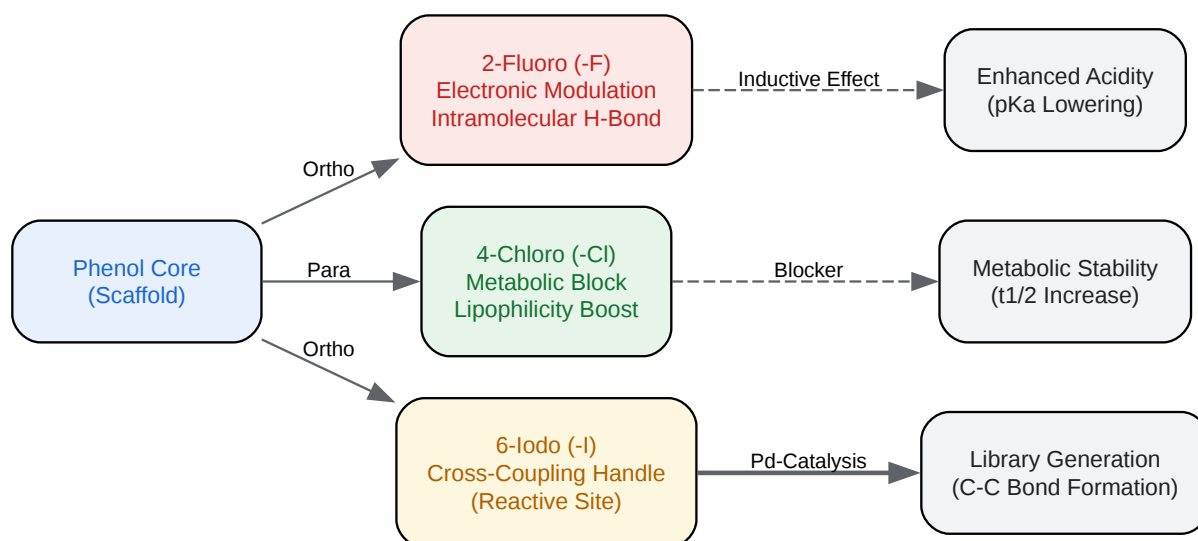

[Click to download full resolution via product page](#)

Figure 1: Functional decomposition of the **4-Chloro-2-fluoro-6-iodophenol** scaffold.

Physicochemical Profile

Accurate physicochemical data is critical for predicting the behavior of this compound in biological assays. As experimental data for this specific isomer is limited in public repositories, values below combine available vendor data with high-confidence predictive models (ACD/Labs, ChemAxon) based on structural analogs.

Table 1: Key Physicochemical Properties[3]

Property	Value (Approx/Predicted)	Significance
Molecular Weight	272.44 g/mol	Fragment-like; suitable for LE (Ligand Efficiency) optimization.
Formula	C ₆ H ₃ ClFIO	Halogen-rich core.
Physical State	Solid (Low Melting)	Likely crystalline solid or semi-solid at RT due to halogen disruption of crystal packing.
Melting Point	45–55 °C (Predicted)	Lower than pure phenol (40.5°C) or 4-chlorophenol (43°C) due to asymmetry.
pKa (Acidic)	6.8 ± 0.5	significantly more acidic than phenol (9.95) due to F/Cl/I electron withdrawal.
LogP (Octanol/Water)	3.1 ± 0.3	Moderate lipophilicity; crosses membranes but requires solubilizers (DMSO).
TPSA	20.23 Å ²	Low polar surface area suggests high passive permeability.
H-Bond Donors	1	The phenolic hydroxyl.
H-Bond Acceptors	1	The phenolic oxygen (F and Cl are poor acceptors).

Synthetic Pathways & Purity Analysis

The synthesis of **4-Chloro-2-fluoro-6-iodophenol** typically proceeds via the regioselective iodination of the commercially available precursor, 4-chloro-2-fluorophenol.

Synthesis Protocol (Regioselective Iodination)

Reaction Logic: The hydroxyl group activates the ortho and para positions. Since the para position is blocked by Chlorine and one ortho position is blocked by Fluorine, electrophilic iodination occurs selectively at the remaining C6 ortho position.

Reagents:

- Precursor: 4-Chloro-2-fluorophenol (CAS 348-62-9)
- Iodinating Agent: N-Iodosuccinimide (NIS) or Iodine Monochloride (ICl).
- Solvent: Acetonitrile (MeCN) or Glacial Acetic Acid.
- Catalyst: Trifluoroacetic acid (TFA) (optional, to accelerate reaction).

Step-by-Step Workflow:

- Dissolution: Dissolve 1.0 eq of 4-chloro-2-fluorophenol in MeCN (0.5 M concentration).
- Addition: Cool to 0°C. Add 1.05 eq of NIS portion-wise over 30 minutes.
- Reaction: Allow to warm to Room Temperature (RT) and stir for 4–12 hours. Monitor via TLC (Hexane/EtOAc 8:2) or LC-MS.
- Quench: Quench with saturated aqueous Sodium Thiosulfate () to remove excess iodine (indicated by color change from brown to yellow/colorless).
- Extraction: Extract with Ethyl Acetate (3x). Wash combined organics with Brine.
- Purification: Dry over , concentrate, and purify via silica gel flash chromatography (Gradient: 0-10% EtOAc in Hexanes).

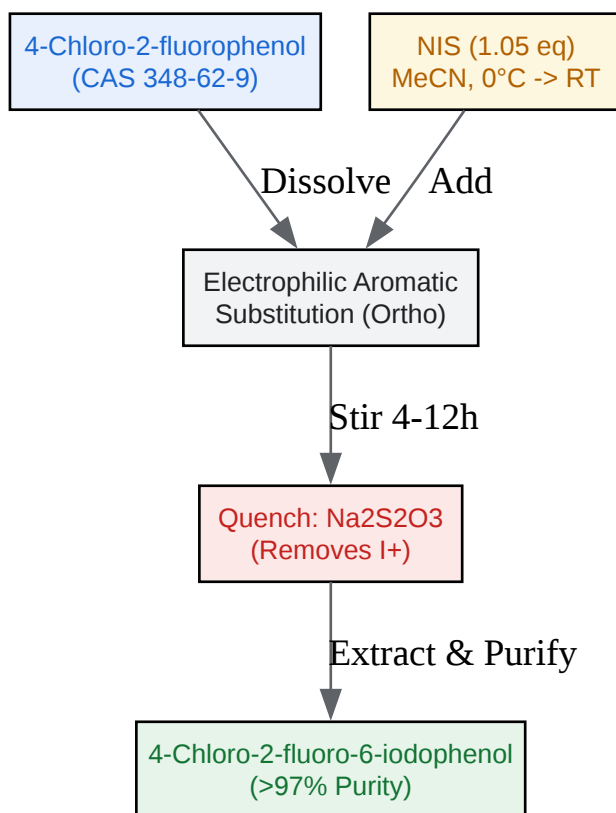

[Click to download full resolution via product page](#)

Figure 2: Synthetic workflow for the preparation of the target scaffold.

Experimental Protocols for Characterization

To ensure scientific integrity, the identity and properties of the synthesized compound must be validated using the following self-validating protocols.

Protocol A: pKa Determination (Spectrophotometric Method)

Why this method? Potentiometric titration may be inaccurate for low-solubility compounds. UV-metric titration is preferred for phenols with pKa < 8.

- Preparation: Prepare a 10 mM stock solution of the compound in DMSO.
- Buffer System: Use a universal buffer (Britton-Robinson) covering pH 2.0 to 12.0.

- Measurement: Dilute stock into buffers to a final concentration of 50 μM .
- Scan: Record UV-Vis spectra (200–400 nm) at each pH step (0.5 unit increments).
- Analysis: Identify the isosbestic point. Plot Absorbance (of phenoxide) vs. pH.
- Calculation: Fit data to the Henderson-Hasselbalch equation:

Validation:^[3] The curve must be sigmoidal with

.

Protocol B: Lipophilicity (LogP) via HPLC

Why this method? Traditional shake-flask methods are time-consuming. Reversed-phase HPLC correlates retention time with hydrophobicity.

- Standards: Calibrate column (C18) using 5 reference standards with known LogP values (e.g., Toluene, Benzene, Acetophenone).
- Mobile Phase: Isocratic Methanol/Water (70:30) + 0.1% Formic Acid (to keep phenol protonated).
- Injection: Inject 10 μL of sample (1 mg/mL in MeOH).
- Calculation: Calculate the capacity factor ():

Where

is retention time and

is dead time (uracil).
- Derivation: Plot

of standards vs. known LogP. Interpolate the sample's LogP.

Applications in Drug Discovery[6][7][8][9][10]

Fragment-Based Drug Discovery (FBDD)

This molecule serves as an ideal "heavy" fragment. The iodine atom allows for the rapid elaboration of the scaffold into bi-aryl systems, while the fluorine/chlorine atoms provide pre-installed metabolic blocking groups.

Bioisosteric Replacement

The 2-fluoro-4-chlorophenol motif is often used to mimic more metabolically labile electron-rich phenols. The addition of iodine allows this motif to be "clicked" onto larger drug frameworks.

Key Reaction: Suzuki-Miyaura Coupling

- Substrate: **4-Chloro-2-fluoro-6-iodophenol** (protected as methyl ether or free phenol with excess base).
- Partner: Aryl boronic acid (
).
- Catalyst:
 or
 .
- Outcome: Selective replacement of the Iodine atom with an aryl group, leaving the Cl and F intact.

Safety & Handling (Halophenol Toxicity)

- Hazard Classification: GHS07 (Warning).
- Risks:
 - H315: Causes skin irritation.[4]
 - H319: Causes serious eye irritation.[4]

- H335: May cause respiratory irritation.[4]
- Handling: All synthesis and handling must occur in a chemical fume hood. Neoprene or Nitrile gloves are required.
- Disposal: Halogenated organic waste. Do not dispose of in general aqueous waste streams due to environmental persistence.

References

- Sigma-Aldrich. "**4-chloro-2-fluoro-6-iodophenol** Product Sheet (CAS 1192815-08-9)." MilliporeSigma.[5] [Link](#)
- PubChem. "4-Chloro-2-iodophenol (Related Isomer Data)." National Library of Medicine. [Link](#)
- ChemScene. "4-Bromo-2-fluoro-6-iodophenol (Physicochemical Analog)." ChemScene. [Link](#)
- EPA CompTox. "2,6-Difluoro-4-iodophenol Properties." US Environmental Protection Agency. [Link](#)[6]
- BenchChem. "Halogenated Acetophenones and Phenols in Medicinal Chemistry." BenchChem Technical Guides. [Link](#)

Need Custom Synthesis?

BenchChem offers custom synthesis for rare earth carbides and specific isotopic labeling.

Email: info@benchchem.com or [Request Quote Online](#).

Sources

- 1. pdf.benchchem.com [pdf.benchchem.com]
- 2. analytical.chem.ut.ee [analytical.chem.ut.ee]
- 3. PubChemLite - 2-bromo-6-fluoro-4-iodophenol (C6H3BrFIO) [pubchemlite.lcsb.uni.lu]
- 4. 4-Chloro-2-iodophenol | C6H4ClIO | CID 620234 - PubChem [pubchem.ncbi.nlm.nih.gov]
- 5. 4-chloro-2-fluoro-6-iodophenol | 1192815-08-9 [sigmaaldrich.com]

- [6. CompTox Chemicals Dashboard \[comptox.epa.gov\]](#)
- To cite this document: BenchChem. [physicochemical properties of 4-Chloro-2-fluoro-6-iodophenol]. BenchChem, [2026]. [Online PDF]. Available at: [\[https://www.benchchem.com/product/b6341347/docs#physicochemical-properties-of-4-chloro-2-fluoro-6-iodophenol\]](https://www.benchchem.com/product/b6341347/docs#physicochemical-properties-of-4-chloro-2-fluoro-6-iodophenol)

Disclaimer & Data Validity:

The information provided in this document is for Research Use Only (RUO) and is strictly not intended for diagnostic or therapeutic procedures. While BenchChem strives to provide accurate protocols, we make no warranties, express or implied, regarding the fitness of this product for every specific experimental setup.

Technical Support: The protocols provided are for reference purposes. Unsure if this reagent suits your experiment?

Need Industrial/Bulk Grade? [Request Custom Synthesis Quote](#)

BenchChem

Our mission is to be the trusted global source of essential and advanced chemicals, empowering scientists and researchers to drive progress in science and industry.

Contact

Address: 3281 E Guasti Rd
Ontario, CA 91761, United States
Phone: (601) 213-4426
Email: info@benchchem.com

[Contact our Ph.D. Support Team for a compatibility check](#)