

Application Notes & Protocols for Catalytic Water Oxidation Using Manganese(III) Phosphate Hydrate

Author: BenchChem Technical Support Team. **Date:** April 2026

Compound of Interest

Compound Name:	MANGANESE(III) PHOSPHATE HYDRATE
CAS No.:	104663-56-1
Cat. No.:	B6336429

[Get Quote](#)

Abstract

Inspired by the oxygen-evolving complex in natural photosynthesis, manganese-based materials have garnered significant attention as earth-abundant, cost-effective catalysts for the water oxidation reaction.^{[1][2]} This guide provides an in-depth technical overview of the application of manganese(III) phosphate monohydrate ($\text{MnPO}_4 \cdot \text{H}_2\text{O}$) as an electrocatalyst for water oxidation. We delve into the rationale behind its catalytic efficacy, offering detailed, field-tested protocols for its synthesis, characterization, and electrochemical evaluation. This document is intended for researchers and scientists engaged in renewable energy, materials science, and catalysis, providing the necessary framework to investigate and utilize this promising catalytic system.

Introduction: The Rationale for Manganese Phosphate

The electrochemical splitting of water into hydrogen and oxygen is a cornerstone of renewable energy strategies. However, the anodic half-reaction, the oxygen evolution reaction (OER), is kinetically sluggish and represents a major bottleneck.[3] Nature's solution is the Mn_4CaO_5 cluster in Photosystem II, which efficiently catalyzes water oxidation under neutral conditions. This biological blueprint has spurred the development of synthetic manganese-based catalysts.

Manganese(III) phosphate hydrate emerges as a compelling candidate due to several key features:

- **Structural Analogy:** The material features distorted manganese centers with water and phosphate ligands, creating an asymmetric coordination environment.[4][5] This structural flexibility is crucial for stabilizing the Jahn-Teller distorted Mn(III) ion, a key intermediate in the catalytic cycle.[3][4][6]
- **Redox Activity:** The accessibility of multiple manganese oxidation states (Mn(III), Mn(IV), Mn(V)) is fundamental to the catalytic mechanism, allowing for the sequential removal of electrons and protons from water molecules.[1][2]
- **Abundance and Stability:** As a compound of earth-abundant elements, it offers a cost-effective alternative to precious metal catalysts like IrO_2 and RuO_2 . [7] Its phosphate framework provides considerable stability under operating conditions.[8]

Catalyst Synthesis: Manganese(III) Phosphate Hydrate ($MnPO_4 \cdot H_2O$)

The synthesis of phase-pure $MnPO_4 \cdot H_2O$ is critical for achieving reproducible catalytic performance. The following protocol is based on the oxidation of a Mn(II) precursor in a phosphate-rich medium.[9][10]

Synthesis Protocol

Materials:

- Manganese(II) sulfate monohydrate ($MnSO_4 \cdot H_2O$)
- Phosphoric acid (H_3PO_4 , 85%)

- Nitric acid (HNO₃, 70%)
- Deionized (DI) water

Procedure:

- Precursor Solution: Prepare a 0.5 M solution of MnSO₄·H₂O in DI water.
- Reaction Mixture: In a separate beaker, add 50 mL of 1.0 M phosphoric acid. While stirring vigorously, slowly add 25 mL of the 0.5 M MnSO₄ solution.
- Oxidation: Gently heat the mixture to 60°C. Carefully add 5 mL of concentrated nitric acid dropwise to the stirring solution. The nitric acid acts as the oxidant to convert Mn(II) to Mn(III).[9]
- Precipitation: Continue stirring at 60°C for 4 hours. A pale-green precipitate of MnPO₄·H₂O will form.[9]
- Isolation and Washing: Allow the solution to cool to room temperature. Collect the precipitate by centrifugation at 4000 rpm for 10 minutes. Discard the supernatant.
- Purification: Wash the solid product three times by re-dispersing it in DI water followed by centrifugation. This step is crucial to remove unreacted ions.
- Drying: Dry the final product in a vacuum oven at 50°C overnight. The resulting powder is pale-green MnPO₄·H₂O.

Synthesis Workflow Visualization

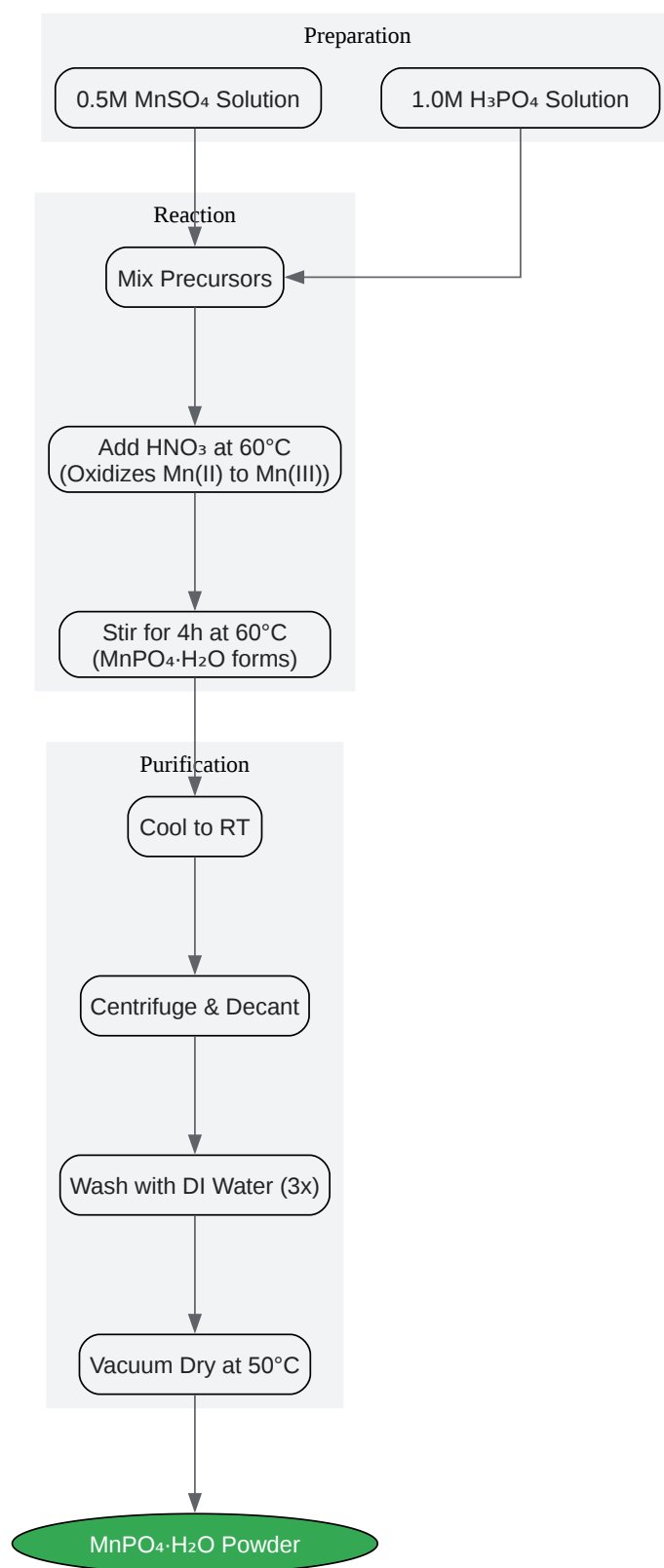

[Click to download full resolution via product page](#)

Caption: Workflow for the synthesis of **Manganese(III) Phosphate Hydrate**.

Material Characterization

Validating the identity, purity, and morphology of the synthesized $\text{MnPO}_4 \cdot \text{H}_2\text{O}$ is a prerequisite for electrochemical studies.

Technique	Purpose	Expected Result
Powder X-ray Diffraction (PXRD)	Phase identification and crystal structure analysis.	The diffraction pattern should match the standard pattern for monoclinic $\text{MnPO}_4 \cdot \text{H}_2\text{O}$ (serrabrancaite). [5]
Scanning Electron Microscopy (SEM)	To observe particle morphology and size.	Typically reveals agglomerates of plate-like or rod-like microcrystals. [1] [4]
Thermogravimetric Analysis (TGA)	To quantify the water of hydration and determine thermal stability.	A weight loss step corresponding to one water molecule (approx. 10.7%) is expected before decomposition at higher temperatures (>400 °C). [9] [11]
X-ray Photoelectron Spectroscopy (XPS)	To determine the elemental composition and oxidation state of manganese.	The Mn 2p and Mn 3s spectra are used to confirm the presence of Mn(III). [1] [12]

Electrochemical Water Oxidation Protocol

The catalytic activity of $\text{MnPO}_4 \cdot \text{H}_2\text{O}$ is evaluated using a standard three-electrode electrochemical setup.[\[7\]](#)[\[13\]](#)

Experimental Setup

- Potentiostat: A standard electrochemical workstation.
- Electrochemical Cell: A single-compartment glass cell.[\[14\]](#)

- Working Electrode (WE): Fluorine-doped tin oxide (FTO) coated glass or a glassy carbon electrode (GCE).
- Counter Electrode (CE): Platinum wire or mesh.
- Reference Electrode (RE): Ag/AgCl (in saturated KCl) or a Saturated Calomel Electrode (SCE). All potentials should be converted to the Reversible Hydrogen Electrode (RHE) scale for universal comparison using the Nernst equation: $E(\text{RHE}) = E(\text{Ag}/\text{AgCl}) + 0.059 \cdot \text{pH} + 0.197 \text{ V}$.^[7]
- Electrolyte: A buffered aqueous solution, typically 0.1 M potassium phosphate buffer (KPi) at pH 7 to mimic biological conditions.

Working Electrode Preparation

- Catalyst Ink: Prepare a stable catalyst ink by dispersing 5 mg of the synthesized $\text{MnPO}_4 \cdot \text{H}_2\text{O}$ powder in a solution containing 450 μL of isopropanol, 450 μL of DI water, and 100 μL of 5 wt% Nafion® solution.
- Sonication: Sonicate the mixture for at least 30 minutes to ensure a homogeneous dispersion. The Nafion® acts as a binder to adhere the catalyst to the electrode surface.
- Deposition: Drop-cast a precise volume (e.g., 10 μL) of the catalyst ink onto the conductive surface of the working electrode (e.g., a 0.25 cm^2 area).
- Drying: Allow the solvent to evaporate slowly at room temperature to form a uniform catalyst film.^[4]

Electrochemical Measurement Protocol

- Setup Assembly: Assemble the three-electrode cell with the prepared WE, Pt CE, and Ag/AgCl RE. Fill the cell with the electrolyte (e.g., 0.1 M KPi, pH 7).
- Electrolyte Saturation: Purge the electrolyte with an inert gas (N_2 or Ar) for 20-30 minutes to remove dissolved oxygen. Maintain a gentle stream of the gas over the electrolyte during measurements.^[13]

- **Conditioning:** Before recording data, cycle the potential (e.g., 10-20 cycles of Cyclic Voltammetry) in the desired potential window to activate and stabilize the catalyst film.
- **Linear Sweep Voltammetry (LSV):** Record the OER activity by sweeping the potential from ~ 0.8 V to ~ 1.8 V vs. RHE at a slow scan rate (e.g., 5-10 mV/s). The onset of the catalytic current indicates the potential at which water oxidation begins.[13]
- **Chronoamperometry (CA):** To assess stability, hold the electrode at a constant potential that elicits a specific current density (e.g., 1 mA/cm²) and record the current as a function of time. A stable catalyst will maintain a steady current over several hours.
- **iR Correction:** Measure the uncompensated solution resistance (R_u) using high-frequency Electrochemical Impedance Spectroscopy (EIS) and apply an iR correction to all polarization data ($V_{\text{corrected}} = V_{\text{applied}} - i \cdot R_u$) for accurate assessment of catalyst kinetics.

Electrochemical Setup Visualization

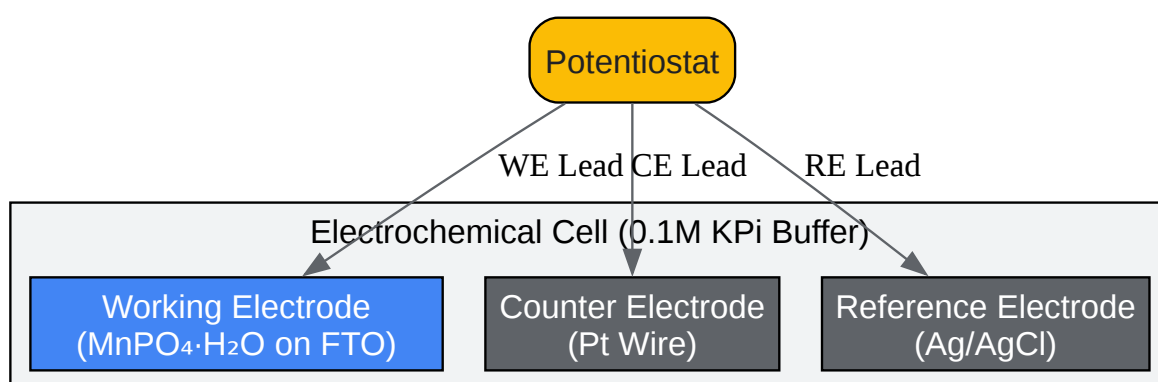

[Click to download full resolution via product page](#)

Caption: A standard three-electrode electrochemical cell setup.

Data Analysis and Performance Metrics

A thorough analysis of the electrochemical data is essential to benchmark the catalyst's performance.

Metric	Definition	How to Determine	Significance
Overpotential (η)	The potential required beyond the thermodynamic minimum (1.23 V vs. RHE) to achieve a specific current density (typically 10 mA/cm ²).	From the iR-corrected LSV curve, find the potential at J = 10 mA/cm ² and calculate $\eta = E(\text{RHE}) - 1.23 \text{ V}$.	A lower overpotential indicates a more efficient catalyst.
Tafel Slope	The slope of the linear region in a plot of overpotential (η) versus the logarithm of the current density (log	J).
Turnover Frequency (TOF)	The number of moles of O ₂ evolved per mole of active catalyst sites per second.	$\text{TOF} = J / (4 * F * n)$ where J is the current density, F is the Faraday constant (96485 C/mol), and n is the number of active sites (moles/cm ²). [15] [16] [17]	Represents the intrinsic activity of the catalyst, allowing for comparison across different materials. [17]

Note on TOF Calculation: Estimating the number of active sites (n) is non-trivial but crucial. One common method for manganese oxides is to integrate the charge of a pre-catalytic redox wave (e.g., Mn(III)/Mn(IV) transition) from the cyclic voltammogram, assuming this represents the electrochemically accessible sites.[\[17\]](#)[\[18\]](#)

Proposed Catalytic Mechanism

The water oxidation mechanism on manganese phosphate is believed to proceed through a series of proton-coupled electron transfer (PCET) steps, culminating in O-O bond formation.[\[1\]](#)

[2] High-valent Mn(V)=O species have been identified as key intermediates responsible for the O-O bond formation step.[1][2]

Catalytic Cycle Visualization

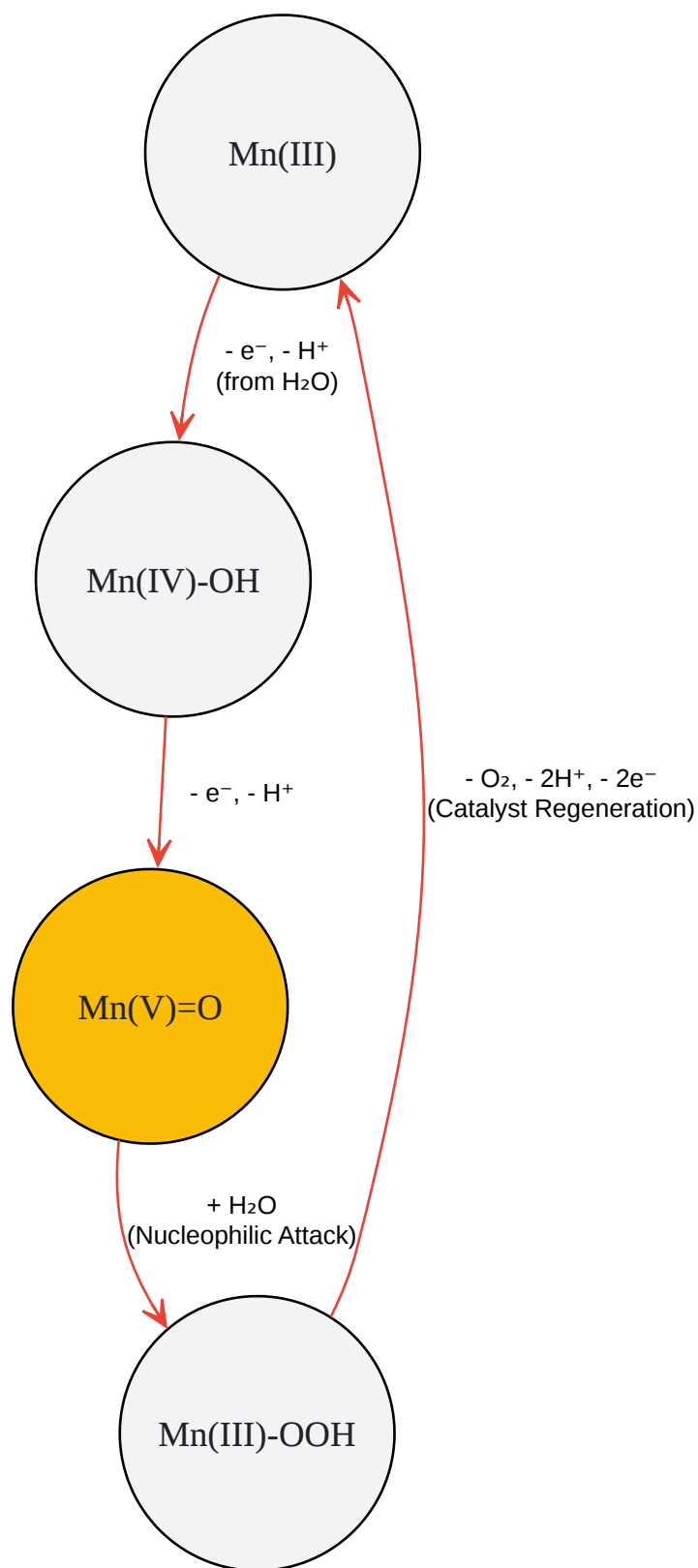

[Click to download full resolution via product page](#)

Caption: Simplified catalytic cycle for water oxidation at a manganese center.

This cycle illustrates the sequential oxidation of the Mn center from (III) to (V). A water molecule attacks the highly electrophilic Mn(V)=O species, leading to the formation of a hydroperoxo intermediate and subsequent release of molecular oxygen, regenerating the Mn(III) resting state. The phosphate framework helps to stabilize these high-valent intermediates.[6]

Conclusion

Manganese(III) phosphate hydrate stands out as a robust and efficient electrocatalyst for water oxidation. Its synthesis is straightforward, and its performance can be rigorously evaluated using standard electrochemical techniques. By understanding the interplay between its structure, redox properties, and catalytic activity, researchers can further optimize this system and contribute to the development of practical and sustainable energy conversion technologies. This guide provides the foundational protocols and scientific rationale to empower such investigations.

References

- Electrocatalytic water oxidation with manganese phosphates. (2024).
- Electrocatalytic water oxidation with manganese phosph
- Electrocatalytic water oxidation using manganese phosph
- Protocol for Screening Water Oxidation or Reduction Electrocatalyst Activity in a Three-Electrode Cell for Alkaline Exchange Membrane Electrolysis. (n.d.). Frontiers.
- Manganese(III)
- Identifying the Active Site of Water Oxidation Catalyst Based on Defective Fe-Doped Ni Oxyhydroxide. (2023). CCS Chemistry.
- Quantification of Active Site Density and Turnover Frequency: From Single-Atom Metal to Nanoparticle Electroc
- Experimental setup for electrochemical oxidation in a batch system. (n.d.).
- Characterization of manganese(III)
- Hydrated Manganese (II) Phosphate ($\text{Mn}_3(\text{PO}_4)_2 \cdot 3\text{H}_2\text{O}$)
- Synthesis and characterization of manganese phosph
- Hydrated manganese(II) phosphate ($\text{Mn}_3(\text{PO}_4)_2 \cdot 3\text{H}_2\text{O}$)
- Hydrated Manganese(II) Phosphate ($\text{Mn}_3(\text{PO}_4)_2 \cdot 3\text{H}_2\text{O}$) as a Water Oxidation Catalyst. (2014). Journal of the American Chemical Society.
- Preparation of Manganese Phosph
- Webinar: Understanding the mechanism of water oxidation on oxide electroc
- Thesis: Reactor design for electrochemical oxidation of the persistent organic pollutant 1,4-dioxane. (n.d.). Mountain Scholar.

- Application of Electrochemical Oxidation for Water and Wastewater Tre
- Water oxidation catalysis – role of redox and structural dynamics in biological photosynthesis and inorganic manganese oxides. (n.d.). Energy & Environmental Science (RSC Publishing).
- Quantification of Active Site Density and Turnover Frequency: From Single-Atom Metal to Nanoparticle Electroc
- (PDF) Manganese(III) Phosphates. (n.d.).
- Manganese(III)
- In Situ Quantification of the Active Sites, Turnover Frequency, and Stability of Ni–Fe (Oxy)hydroxides for the Oxygen Evolution Reaction. (2022).
- The Significance of Properly Reporting Turnover Frequency in Electrocatalysis Research. (2021). Wiley Online Library.

Need Custom Synthesis?

BenchChem offers custom synthesis for rare earth carbides and specific isotopic labeling.

Email: info@benchchem.com or [Request Quote Online](#).

Sources

1. [researchgate.net](https://www.researchgate.net) [[researchgate.net](https://www.researchgate.net)]
2. [Electrocatalytic water oxidation with manganese phosphates - PubMed](https://pubmed.ncbi.nlm.nih.gov/) [pubmed.ncbi.nlm.nih.gov]
3. pubs.acs.org [pubs.acs.org]
4. pdf.benchchem.com [pdf.benchchem.com]
5. pubs.acs.org [pubs.acs.org]
6. pure.kaist.ac.kr [pure.kaist.ac.kr]
7. chinesechemsoc.org [chinesechemsoc.org]
8. chemimpex.com [chemimpex.com]
9. [Manganese\(III\) phosphate - Wikipedia](https://en.wikipedia.org/wiki/Manganese(III)_phosphate) [[en.wikipedia.org](https://en.wikipedia.org/wiki/Manganese(III)_phosphate)]
10. echemi.com [echemi.com]
11. pstorage-acs-6854636.s3.amazonaws.com [pstorage-acs-6854636.s3.amazonaws.com]
12. pdf.benchchem.com [pdf.benchchem.com]

- [13. Frontiers | Protocol for Screening Water Oxidation or Reduction Electrocatalyst Activity in a Three-Electrode Cell for Alkaline Exchange Membrane Electrolysis \[frontiersin.org\]](#)
- [14. researchgate.net \[researchgate.net\]](#)
- [15. pubs.acs.org \[pubs.acs.org\]](#)
- [16. Quantification of Active Site Density and Turnover Frequency: From Single-Atom Metal to Nanoparticle Electrocatalysts - PMC \[pmc.ncbi.nlm.nih.gov\]](#)
- [17. The Significance of Properly Reporting Turnover Frequency in Electrocatalysis Research - PMC \[pmc.ncbi.nlm.nih.gov\]](#)
- [18. pubs.acs.org \[pubs.acs.org\]](#)
- [To cite this document: BenchChem. \[Application Notes & Protocols for Catalytic Water Oxidation Using Manganese\(III\) Phosphate Hydrate\]. BenchChem, \[2026\]. \[Online PDF\]. Available at: \[https://www.benchchem.com/product/b6336429/docs#application-notes-protocols-for-catalytic-water-oxidation-using-manganese-iii-phosphate-hydrate\]](#)

Disclaimer & Data Validity:

The information provided in this document is for Research Use Only (RUO) and is strictly not intended for diagnostic or therapeutic procedures. While BenchChem strives to provide accurate protocols, we make no warranties, express or implied, regarding the fitness of this product for every specific experimental setup.

Technical Support: The protocols provided are for reference purposes. Unsure if this reagent suits your experiment?

Need Industrial/Bulk Grade? [Request Custom Synthesis Quote](#)

BenchChem

Our mission is to be the trusted global source of essential and advanced chemicals, empowering scientists and researchers to drive progress in science and industry.

Contact

Address: 3281 E Guasti Rd

Ontario, CA 91761, United States

Phone: (601) 213-4426

Email: info@benchchem.com

Contact our Ph.D. Support Team for a compatibility check