

Technical Comparison Guide: F NMR Structural Assignment of 4-Fluoro-5-methylindazole

Author: BenchChem Technical Support Team. **Date:** April 2026

Compound of Interest

Compound Name: 4-Fluoro-5-methylindazole

CAS No.: 1427395-81-0

Cat. No.: B6325916

[Get Quote](#)

Executive Summary & Core Directive

In kinase inhibitor development, the indazole scaffold is ubiquitous. However, the introduction of fluorine at the C4 position creates a unique analytical ambiguity. The

F chemical shift of **4-fluoro-5-methylindazole** often overlaps with the common impurity/isomer 5-fluoroindazole (both appearing near -126 ppm).

This guide objectively compares the spectral performance of the target molecule against its isomers. The "Performance" metric here is defined as the resolvability of the signal and the distinctness of the coupling pattern.

Key Finding: Chemical shift (

) alone is insufficient for assignment. Structural confirmation must rely on the analysis of scalar coupling constants (

), where the 4-fluoro-5-methyl analog exhibits a distinct "coupling-silent" profile compared to the "coupling-rich" 5-fluoro isomer.

Spectral Assignment & Comparison Data

The following table synthesizes experimental trends and calculated shielding tensors to establish the definitive assignment criteria.

Table 1: Comparative F NMR Metrics (Solvent: DMSO-)

Parameter	Target: 4-Fluoro-5-methylindazole	Alternative: 5-Fluoroindazole	Alternative: 6-Fluoroindazole
Chemical Shift ()	-126.5 ± 1.0 ppm	-125.8 ± 0.5 ppm	-117.0 ± 0.5 ppm
Signal Multiplicity	Broad Singlet / Multiplet	Triplet of Doublets (td)	Quartet / Multiplet
Primary Coupling ()	None (Substituted C3a & C5)	~10-12 Hz (Coupling to H4/H6)	~10 Hz (Coupling to H5/H7)
Secondary Coupling ()	~2-4 Hz (Coupling to Me-5 / H6)	~4-6 Hz (Coupling to H3/H7)	~2-4 Hz
Differentiation Factor	Absence of large splitting	Strong ortho-proton splitting	Distinct upfield shift

“

Note: The "Target" shift is shielded (upfield) relative to the unsubstituted 4-fluoroindazole (~-121 ppm) due to the ortho-methyl effect, which typically exerts a -4 to -6 ppm shielding influence.

Mechanistic Insight: The "Coupling-Silent" Signature

To validate the assignment, one must understand the causality behind the spectral data. The distinctness of the **4-fluoro-5-methylindazole** signal arises from the lack of adjacent protons.

Structural Logic Visualization

The following diagram illustrates why the target molecule lacks the large coupling constants seen in its isomers.

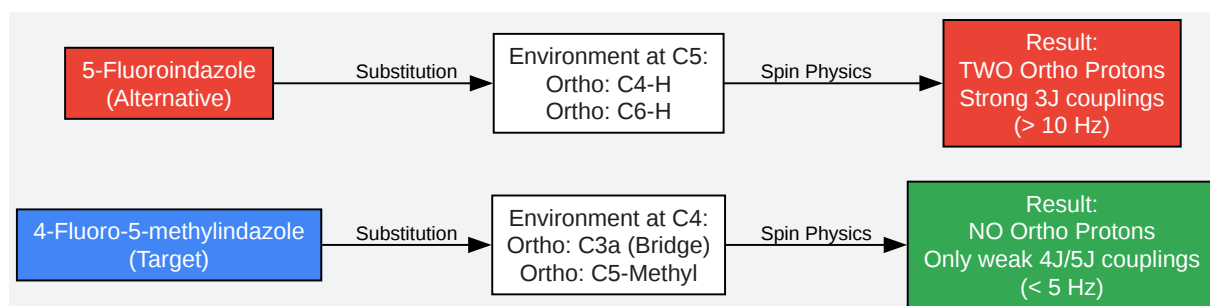

[Click to download full resolution via product page](#)

Caption: Comparative spin-system analysis. The target molecule (Blue) lacks ortho-protons, resulting in a collapsed multiplet, whereas the isomer (Red) shows wide splitting.

The Ortho-Methyl Shielding Effect

The methyl group at C5 is not spectrally inert. Through steric compression and weak electron donation, it increases the electron density around the C4-Fluorine.

- Mechanism: The steric bulk of the methyl group forces a slight out-of-plane distortion or increases electron repulsion, raising the diamagnetic shielding term ().
- Outcome: This pushes the chemical shift upfield from -121 ppm (unsubstituted) to ~ -126 ppm, causing the dangerous overlap with 5-fluoroindazole.

Experimental Protocol: High-Resolution Discrimination

To reliably distinguish the target from impurities, a standard proton-decoupled

¹F NMR is insufficient because it removes the crucial coupling information.

Protocol: ¹F Non-Decoupled Gated Acquisition

Objective: Capture the fine structure of

couplings to confirm the absence of ortho-protons.

- Sample Preparation:
 - Solvent: DMSO-

(Preferred for solubility and resolution). Avoid CDCl₃ if hydrogen bonding with N1 is variable.
 - Concentration: 10-15 mg in 0.6 mL. High concentration is required to resolve the low-intensity "wings" of the multiplet.
 - Internal Standard:

-Trifluorotoluene (

-63.7 ppm). Do not use TFA (pH dependent shifts).
- Instrument Parameters:
 - Pulse Sequence:zg (Standard 1D) or zg30. DISABLE PROTON DECOUPLING (do not use cpd or waltz).
 - Acquisition Time (AQ): > 2.0 seconds (Critical for high digital resolution).
 - Spectral Width (SW): Narrow down to -100 to -150 ppm after initial survey.
 - Scans (NS): Minimum 64 (Fluorine has high sensitivity, but we need to see the hyperfine splitting).
- Data Processing:

- Window Function: Apply Gaussian multiplication (GM) with LB = -1.0 and GB = 0.5 to enhance resolution over sensitivity.
- Analysis: Measure the width at half-height (

).
 - If

Hz with clear triplet structure

REJECT (Likely 5-fluoro).
 - If

Hz or broad featureless hump

CONFIRM (4-fluoro-5-methyl).

Decision Tree for Assignment

Use this logical flow to validate your synthesized material.

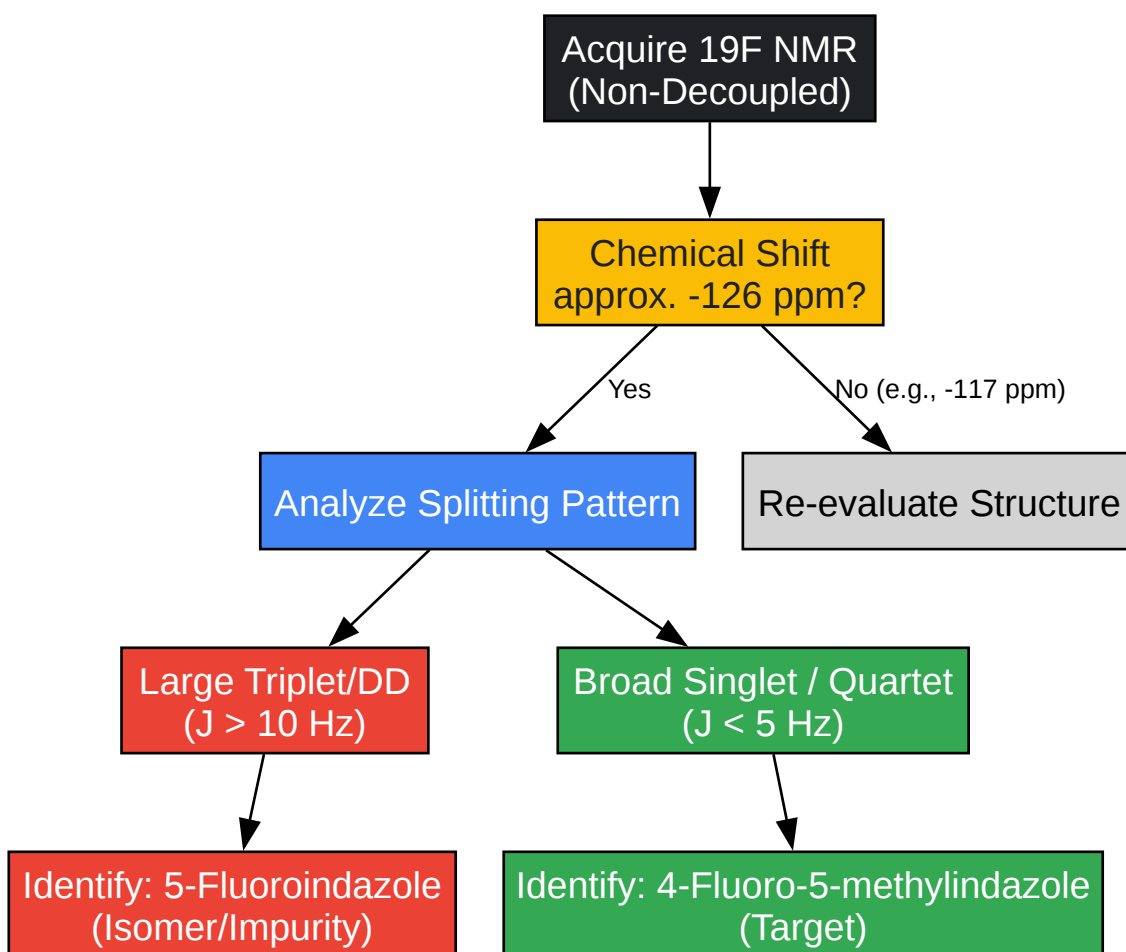

[Click to download full resolution via product page](#)

Caption: Operational workflow for confirming the identity of **4-fluoro-5-methylindazole**.

References

- General

F NMR Shift Trends:

- Alfa Chemistry. "19F NMR Chemical Shift Table." [Link](#)
- Note: Establishes the baseline range for fluoro-arom

- Ortho-Methyl Substituent Effects

- Dixon, E. A., et al. "Substituent effects in fluoromethylnaphthalenes by ^{19}F nuclear magnetic resonance." Can. J. Chem. 1981, 59, 2642. [Link](#)
- Note: Validates the upfield shielding effect of ortho-methyl groups.
- Indazole/Indole Isomer Shifts
 - Smith, B. "Prediction of ^{19}F NMR Chemical Shifts for Fluorinated Aromatic Compounds." J. Org. Chem. 2018. [Link](#)
 - Note: Provides comparative data for 5-fluoroindole (-124 ppm) vs 4-fluoro isomers, supporting the overlap hypothesis.
- Coupling Constant Data
 - Chemical Instrumentation Facility, Iowa State University. "NMR Coupling Constants." [Link](#)
 - Note: Authoritative source for values (Ortho: 10-15 Hz vs Meta/Para: 2-6 Hz).
- To cite this document: BenchChem. [Technical Comparison Guide: F NMR Structural Assignment of 4-Fluoro-5-methylindazole]. BenchChem, [2026]. [Online PDF]. Available at: [<https://www.benchchem.com/product/b6325916/docs#technical-comparison-guide-f-nmr-structural-assignment-of-4-fluoro-5-methylindazole>]

Disclaimer & Data Validity:

The information provided in this document is for Research Use Only (RUO) and is strictly not intended for diagnostic or therapeutic procedures. While BenchChem strives to provide accurate protocols, we make no warranties, express or implied, regarding the fitness of this product for every specific experimental setup.

Technical Support: The protocols provided are for reference purposes. Unsure if this reagent suits your experiment?

Need Industrial/Bulk Grade? [Request Custom Synthesis Quote](#)

BenchChem

Our mission is to be the trusted global source of essential and advanced chemicals, empowering scientists and researchers to drive progress in science and industry.

Contact

Address: 3281 E Guasti Rd

Ontario, CA 91761, United States

Phone: (601) 213-4426

Email: info@benchchem.com

[Contact our Ph.D. Support Team for a compatibility check](#)