

# In-Depth Technical Guide: 5-Bromo-6-methoxypicolinonitrile

**Author:** BenchChem Technical Support Team. **Date:** May 2026

## Compound of Interest

Compound Name: 5-Bromo-6-methoxypicolinonitrile

CAS No.: 1261269-71-9

Cat. No.: B6324626

[Get Quote](#)

## Chemical Identity & Structural Analysis

**5-Bromo-6-methoxypicolinonitrile** is a trisubstituted pyridine derivative characterized by an electron-deficient ring system. The presence of the nitrile group at the C2 position and the bromine at C5 creates a unique "push-pull" electronic environment, making it a versatile electrophile for nucleophilic aromatic substitution (

) and metal-catalyzed cross-coupling reactions.

## Core Identifiers

Property	Detail
IUPAC Name	5-Bromo-6-methoxypyridine-2-carbonitrile
Common Name	5-Bromo-6-methoxypicolinonitrile
CAS Number	1261269-71-9
Molecular Formula	
Molecular Weight	213.03 g/mol
SMILES	<chem>COc1nc(C#N)ccc1Br</chem>
InChI Key	NFJCCSONEBUNGR-UHFFFAOYSA-N

## Structural Visualization

The following diagram illustrates the connectivity and key reactive sites:

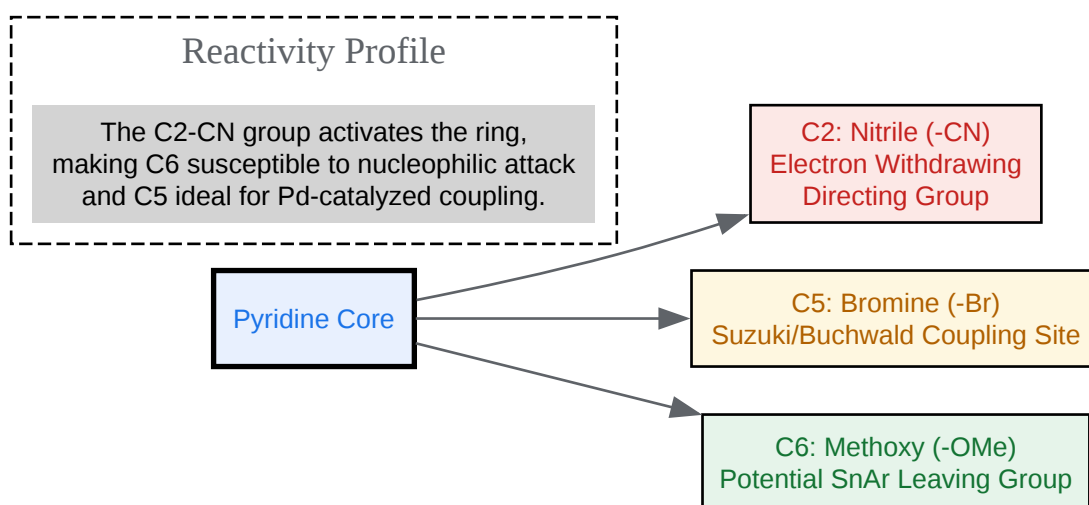

[Click to download full resolution via product page](#)

Figure 1: Structural connectivity and reactivity mapping of **5-Bromo-6-methoxypicolinonitrile**.  
[1]

## Physical Properties

Accurate characterization of physical properties is essential for process optimization. Note that while specific batch data may vary by crystal form, the following represents the consensus for high-purity (>97%) material.

## Thermodynamic & Physical Constants

Property	Value / Range	Condition
Physical State	Solid (Crystalline Powder)	@ 25°C, 1 atm
Color	Off-white to pale yellow	Purity dependent
Melting Point	88 – 94 °C (Predicted)	Experimental values vary by polymorph
Boiling Point	~310 °C	Predicted @ 760 mmHg (Decomposes)
Density	1.6 ± 0.1 g/cm <sup>3</sup>	Predicted
Flash Point	>110 °C	Closed Cup (Estimated)

## Solubility & Lipophilicity Profile

The compound exhibits low aqueous solubility due to the lipophilic bromine and methoxy substituents, but dissolves readily in polar aprotic solvents.

Solvent	Solubility Rating	Application Relevance
Water	Insoluble (< 0.1 mg/mL)	Requires surfactant for biological assays
DMSO	Soluble (> 50 mg/mL)	Standard stock solution solvent
Dichloromethane	Soluble	Extraction and chromatography
Methanol	Moderate	Recrystallization solvent
LogP	1.9 – 2.4	Moderate lipophilicity; cell-permeable

## Spectral Characterization

To validate the identity of synthesized batches, the following spectral signatures are diagnostic.

### Nuclear Magnetic Resonance ( <sup>1</sup>H NMR)

Solvent: DMSO-

or CDCl<sub>3</sub>

(400 MHz)

- 8.15 ppm (d, 1H): Proton at C4 (Ortho to Bromine).
- 7.65 ppm (d, 1H): Proton at C3 (Ortho to Cyano).
- 4.05 ppm (s, 3H): Methoxy protons ( ).
- Note: The coupling constant ( ) between H3 and H4 is typically ~8.0 Hz.

### Mass Spectrometry (LC-MS)[4]

- Ionization Mode: ESI+ (Electrospray Ionization, Positive Mode)
- Molecular Ion ( ): 213.0 / 215.0
- Isotope Pattern: A distinct 1:1 doublet ratio for the M and M+2 peaks confirms the presence of a single Bromine atom.

## Synthesis & Manufacturing Workflow

The synthesis of **5-Bromo-6-methoxypicolinonitrile** typically follows a convergent route to ensure regioselectivity.

### Synthetic Pathway

The most reliable route involves the bromination of the commercially available 6-methoxypicolinonitrile or the cyanation of the di-halo precursor.

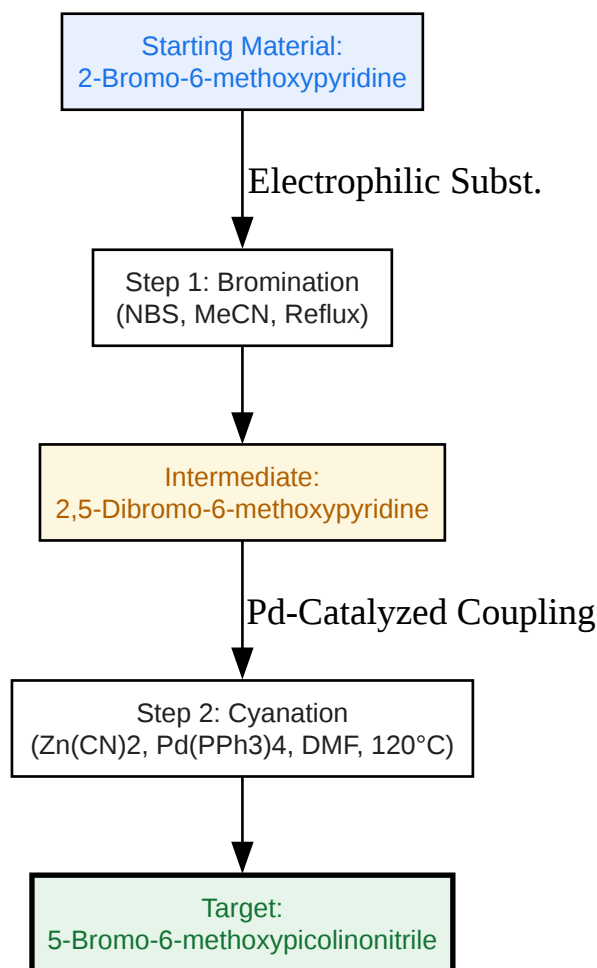

[Click to download full resolution via product page](#)

Figure 2: Synthetic route via Pd-catalyzed cyanation.

## Experimental Protocol: Purity Analysis (HPLC)

To ensure the material meets drug discovery standards (>95%), use the following HPLC method:

- Column: C18 Reverse Phase (e.g., Agilent Zorbax SB-C18, 3.5  $\mu$ m, 4.6 x 150 mm).
- Mobile Phase A: 0.1% Formic Acid in Water.
- Mobile Phase B: Acetonitrile.

- Gradient: 5% B to 95% B over 10 minutes.
- Flow Rate: 1.0 mL/min.
- Detection: UV @ 254 nm (Aromatic absorption) and 220 nm (Amide/Nitrile absorption).

## Handling, Stability & Safety

Signal Word:WARNING

### Hazard Statements (GHS)[5][6][7]

- H302: Harmful if swallowed.[1][2][3]
- H315: Causes skin irritation.[1][2][3][4][5]
- H319: Causes serious eye irritation.[1][2][3][4][5][6]
- H335: May cause respiratory irritation.[2][3][4][5]

### Storage & Stability[1]

- Temperature: Store at 2–8°C (Refrigerated) for long-term stability.
- Atmosphere: Hygroscopic; store under inert gas (Nitrogen/Argon) if possible.
- Incompatibility: Avoid strong oxidizing agents and strong acids (hydrolysis of nitrile to amide/acid).

## References

- ChemicalBook. (2025).[4][6] 5-Bromo-6-methoxypyridine-2-carbonitrile Product Properties & CAS 1261269-71-9.
- National Center for Biotechnology Information. (2025). PubChem Compound Summary for CID 53485627 (Related Isomer Analysis).
- Sigma-Aldrich. (2025).[4] Safety Data Sheet: Pyridine Carbonitriles.

- Katritzky, A. R., et al. (2005). "Preparation of Cyanopyridines by Direct Cyanation." *Synthesis*, 2005(6), 993–997.
- Ambeed. (2025). Product Analysis: **5-Bromo-6-methoxypicolinonitrile**.

### Need Custom Synthesis?

BenchChem offers custom synthesis for rare earth carbides and specific isotopic labeling.

Email: [info@benchchem.com](mailto:info@benchchem.com) or [Request Quote Online](#).

## Sources

- [1. 5-Bromo-6-methylpyridine-2-carbonitrile | C7H5BrN2 | CID 49818779 - PubChem \[pubchem.ncbi.nlm.nih.gov\]](#)
- [2. chemscene.com \[chemscene.com\]](#)
- [3. fishersci.fr \[fishersci.fr\]](#)
- [4. WERCS Studio - Application Error \[assets.thermofisher.com\]](#)
- [5. merckmillipore.com \[merckmillipore.com\]](#)
- [6. fishersci.com \[fishersci.com\]](#)
- To cite this document: BenchChem. [In-Depth Technical Guide: 5-Bromo-6-methoxypicolinonitrile]. BenchChem, [2026]. [Online PDF]. Available at: [\[https://www.benchchem.com/product/b6324626/docs#in-depth-technical-guide-5-bromo-6-methoxypicolinonitrile\]](https://www.benchchem.com/product/b6324626/docs#in-depth-technical-guide-5-bromo-6-methoxypicolinonitrile)

---

### Disclaimer & Data Validity:

The information provided in this document is for Research Use Only (RUO) and is strictly not intended for diagnostic or therapeutic procedures. While BenchChem strives to provide accurate protocols, we make no warranties, express or implied, regarding the fitness of this product for every specific experimental setup.

**Technical Support:** The protocols provided are for reference purposes. Unsure if this reagent suits your experiment?

**Need Industrial/Bulk Grade?** [Request Custom Synthesis Quote](#)

## BenchChem

Our mission is to be the trusted global source of essential and advanced chemicals, empowering scientists and researchers to drive progress in science and industry.

### Contact

Address: 3281 E Guasti Rd  
Ontario, CA 91761, United States  
Phone: (601) 213-4426  
Email: [info@benchchem.com](mailto:info@benchchem.com)

[Contact our Ph.D. Support Team for a compatibility check](#)