

Comparative Reactivity Guide: Bromo-Fluoro-Indazole Isomers

Author: BenchChem Technical Support Team. **Date:** May 2026

Compound of Interest

Compound Name: 7-Bromo-6-fluoro-1H-indazole

CAS No.: 1427377-75-0

Cat. No.: B6308890

[Get Quote](#)

Executive Summary

Audience: Medicinal Chemists, Process Chemists. **Scope:** This guide analyzes the divergent reactivity profiles of bromo-fluoro-1H-indazole isomers, specifically focusing on the interplay between the bromine "handle" (for cross-coupling) and the fluorine "activator/handle" (for SNAr or directed lithiation).

Key Takeaway: The relative position of the fluorine atom dictates the regioselectivity of metalation and the lability of the bromine bond.

- 5-Bromo-4-fluoroindazole: Highly reactive in C5-cross-coupling due to the ortho-fluorine inductive effect. The C3 position is hyper-activated for deprotonation.
- 5-Bromo-6-fluoroindazole: chemically similar regarding Br-reactivity but distinct in lithiation patterns (directing C7-lithiation vs. C3).
- **Synthesis Strategy:** Unlike simple indazoles, these isomers are best synthesized via de novo ring construction from fluorinated anilines, rather than direct halogenation of the indazole core, to ensure isomeric purity.

Structural & Electronic Landscape

The indazole core consists of a benzene ring fused to a pyrazole. The numbering system and electronic bias are critical for predicting reactivity.

Electronic Bias Table

Position	Electronic Character	Dominant Effect of Fluorine Substitution
C3	Electron-deficient (Imine-like)	Acidic C-H: pKa ~35. F at C4 increases acidity via induction.
C4	Ortho to Bridgehead	Steric/Electronic Gate: F here strongly activates C5-Br and C3-H.
C5	Meta to Bridgehead	Primary Coupling Site: Br here is the standard handle.
C6	Para to Bridgehead	Remote Director: F here directs lithiation to C7.
C7	Ortho to N1	Steric Gate: F here hinders N1-alkylation, potentially shifting selectivity to N2.

Reactivity Profile 1: Palladium-Catalyzed Cross-Coupling (Suzuki-Miyaura)

The bromine atom at C5 is the primary electrophilic site. However, its reactivity is modulated by the position of the fluorine atom.

Comparative Kinetics

- 5-Bromo-4-fluoro-1H-indazole:
 - Reactivity: Highest. The fluorine at C4 is ortho to the C5-Br bond. The strong inductive withdrawal (-I effect) of fluorine depletes electron density from the C5-Br bond, facilitating the rate-limiting oxidative addition of Pd(0).

- Sterics: Minimal impact. Although C4 is adjacent to the bridgehead, planar ligands (e.g., XPhos, SPhos) accommodate this easily.
- 5-Bromo-6-fluoro-1H-indazole:
 - Reactivity: High. Similar ortho-activation (F is at C6, Br at C5).
 - Differentiation: The C6-F isomer is less sterically crowded relative to the C3/C3a region, often resulting in slightly cleaner reaction profiles with bulky boronic acids.

Experimental Data Summary (Suzuki Coupling)

Substrate	Catalyst System	Base/Solvent	Yield	Notes
5-Br-4-F-Indazole	Pd(dppf)Cl ₂ (5 mol%)	K ₂ CO ₃ / Dioxane:H ₂ O	88-95%	Fast oxidative addition (1-2 h).
5-Br-6-F-Indazole	Pd(dppf)Cl ₂ (5 mol%)	K ₂ CO ₃ / Dioxane:H ₂ O	85-92%	Comparable yield; slightly slower kinetics.
5-Br-Indazole (Control)	Pd(dppf)Cl ₂ (5 mol%)	K ₂ CO ₃ / Dioxane:H ₂ O	75-85%	Slower; requires higher temp or longer time.

Reactivity Profile 2: Nucleophilic Aromatic Substitution (S_NAr)[1]

Fluorine is generally a poor leaving group unless activated by strong electron-withdrawing groups (EWGs). In indazoles, the pyrazole ring acts as a weak EWG.

- Mechanism: Addition-Elimination (Meisenheimer Complex).
- Lability Hierarchy:
 - 4-Fluoro: Most reactive. Proximity to the electron-deficient pyrazole ring (C3a bridgehead) lowers the transition state energy for nucleophilic attack.

- 7-Fluoro: Reactive. Ortho to the N1 nitrogen. If N1 is acetylated or sulfonated (EWG protection), F at C7 becomes highly labile.
- 5-Fluoro / 6-Fluoro: Least reactive. Requires additional EWGs (e.g., -NO₂, -CN) on the ring or harsh conditions (high temp, strong nucleophile) to displace F.

Critical Insight: If you need to retain the Fluorine atom, avoid using strong nucleophiles (e.g., NaOMe, thiols) at high temperatures (>100°C) on 4-fluoro derivatives.

Reactivity Profile 3: Lithiation & Functionalization[2]

This is where the isomers diverge most significantly. The "Directing Group" (DG) ability of Fluorine vs. the inherent acidity of C3-H creates competing pathways.

Decision Matrix: Lithiation Pathways

- Reagent: LDA (Lithium Diisopropylamide) - Thermodynamic Base.
- Reagent: n-BuLi (n-Butyllithium) - Kinetic Base / Halogen-Metal Exchange.

Isomer	Reagent	Primary Outcome	Mechanism
5-Br-4-F	LDA	C3-Li	F at C4 directs to C3 (ortho). C3 is also naturally acidic. Cooperative effect.
5-Br-4-F	n-BuLi	C5-Li	Rapid Halogen-Metal Exchange (Br → Li). Faster than deprotonation at -78°C.
5-Br-6-F	LDA	C3-Li / C7-Li	Competition. C3 is naturally acidic. F at C6 directs to C7 (ortho). Mixture possible.
5-Br-6-F	n-BuLi	C5-Li	Rapid Halogen-Metal Exchange.

Visual Pathway (DOT Diagram):

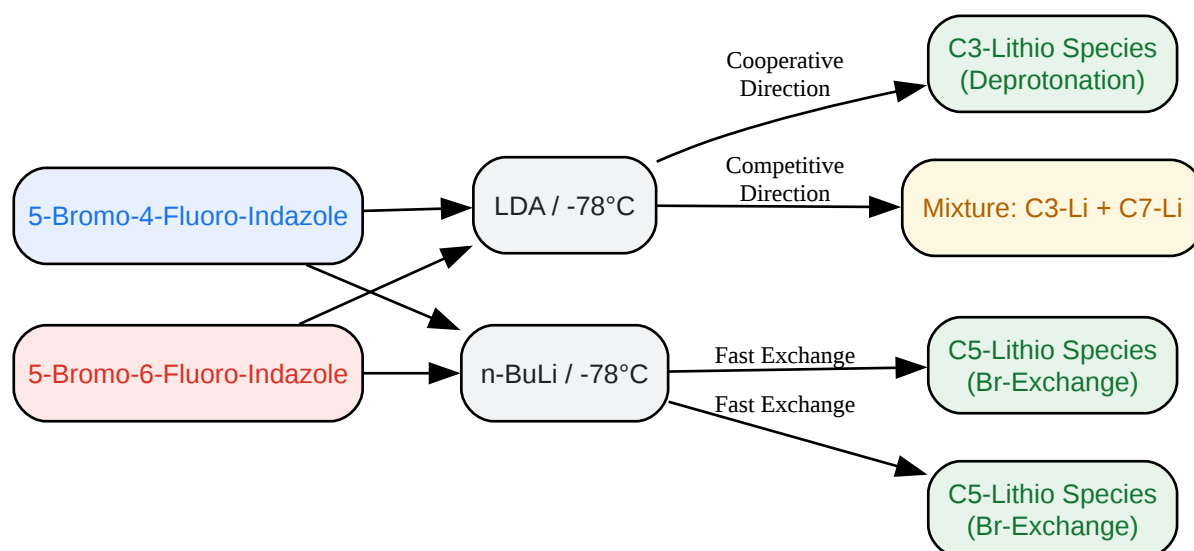

[Click to download full resolution via product page](#)

Caption: Divergent lithiation pathways for 4-fluoro vs 6-fluoro isomers controlled by base selection.

Experimental Protocols

Protocol A: Regioselective Suzuki Coupling of 5-Bromo-4-fluoro-1H-indazole

Validated for scale-up (10g scale).

- Setup: Charge a 3-neck flask with 5-bromo-4-fluoro-1H-indazole (1.0 equiv), Aryl-Boronic Acid (1.2 equiv), and K_2CO_3 (2.0 equiv).
- Solvent: Add 1,4-Dioxane/Water (4:1 ratio, 0.2 M concentration). Degas by sparging with Argon for 15 min.
- Catalyst: Add $Pd(dppf)Cl_2[1][2] \cdot DCM$ (0.03 - 0.05 equiv).
- Reaction: Heat to 85°C. Monitor by HPLC.
 - Note: 4-Fluoro isomer typically reaches >98% conversion within 2 hours.
- Workup: Cool to RT. Dilute with EtOAc. Wash with brine. Dry over Na_2SO_4 .
- Purification: Flash chromatography (Hexane/EtOAc).

Protocol B: N1-Selective Alkylation

Applies to both isomers to lock the tautomer.

- Reagents: Indazole substrate (1.0 equiv), Alkyl Halide (1.1 equiv), Cs_2CO_3 (2.0 equiv).
- Solvent: Dry Acetonitrile or DMF.
- Conditions: Stir at 60°C for 4 hours.
- Mechanism: The Cesium ion (Cs^+) coordinates with N_2 and the carboxylate/halide, directing alkylation to the thermodynamic N_1 position via a "Chelation Control" model.

- Regioselectivity: Typically >10:1 (N1:N2).

Synthesis Workflow (De Novo Construction)

Do not attempt to brominate fluorindazole directly; you will get inseparable mixtures. Use the "Bartoli-style" or "Diazotization" approach from anilines.

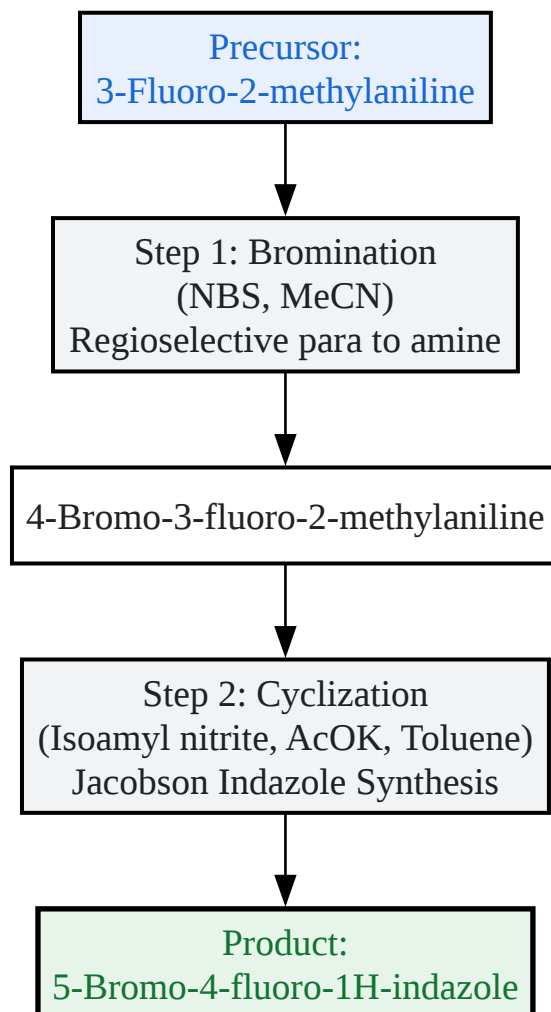

[Click to download full resolution via product page](#)

Caption: Recommended synthetic route for high-purity 5-bromo-4-fluoro-1H-indazole.

References

- National Institutes of Health (NIH). Regioselective alkylation of a versatile indazole: Electrophile scope and mechanistic insights. Available at: [\[Link\]](#)

- MDPI Molecules. Base-Promoted S_NAr Reactions of Fluoro- and Chloroarenes as a Route to N-Aryl Indoles. [3] Available at: [\[Link\]](#)
- Tianming Pharmaceutical. 5-Bromo-4-fluoro-1-methyl-1H-indazole Product Specifications. Available at: [\[Link\]](#)

Need Custom Synthesis?

BenchChem offers custom synthesis for rare earth carbides and specific isotopic labeling.

Email: info@benchchem.com or [Request Quote Online](#).

Sources

- 1. pdf.benchchem.com [pdf.benchchem.com]
- 2. The Suzuki Reaction Applied to the Synthesis of Novel Pyrrolyl and Thiophenyl Indazoles - PMC [[pmc.ncbi.nlm.nih.gov](https://pubmed.ncbi.nlm.nih.gov/)]
- 3. [researchgate.net](https://www.researchgate.net) [[researchgate.net](https://www.researchgate.net)]
- To cite this document: BenchChem. [Comparative Reactivity Guide: Bromo-Fluoro-Indazole Isomers]. BenchChem, [2026]. [Online PDF]. Available at: [<https://www.benchchem.com/product/b6308890/docs#comparative-reactivity-guide-bromo-fluoro-indazole-isomers>]

Disclaimer & Data Validity:

The information provided in this document is for Research Use Only (RUO) and is strictly not intended for diagnostic or therapeutic procedures. While BenchChem strives to provide accurate protocols, we make no warranties, express or implied, regarding the fitness of this product for every specific experimental setup.

Technical Support: The protocols provided are for reference purposes. Unsure if this reagent suits your experiment?

Need Industrial/Bulk Grade? [Request Custom Synthesis Quote](#)

BenchChem

Our mission is to be the trusted global source of essential and advanced chemicals, empowering scientists and researchers to drive progress in science and industry.

Contact

Address: 3281 E Guasti Rd

Ontario, CA 91761, United States

Phone: (601) 213-4426

Email: info@benchchem.com

[Contact our Ph.D. Support Team for a compatibility check](#)