

# Technical Support Center: Suzuki Coupling with Electron-Deficient Boronic Acids

**Author:** BenchChem Technical Support Team. **Date:** April 2026

## Compound of Interest

**Compound Name:** 5-Chloro-2-fluoro-4-isopropoxyphenylboronic acid

**CAS No.:** 2121511-67-7

**Cat. No.:** B6304605

[Get Quote](#)

Status: Active Ticket ID: SC-EWG-BORON-001 Assigned Specialist: Senior Application Scientist Subject: Troubleshooting Low Yields with Unstable/Electron-Deficient Boronic Acids

## Executive Summary

You are likely experiencing rapid protodeboronation. Electron-deficient boronic acids (e.g., 2-pyridineboronic acid, polyfluorophenylboronic acid) possess a highly electrophilic boron center. Under standard basic Suzuki conditions, these species undergo base-catalyzed hydrolysis (protodeboronation) faster than they can undergo transmetallation with the palladium catalyst.

To solve this, we must accelerate transmetallation (using specialized ligands) or throttle the release of the active boronate species (using surrogates or slow addition).

## Diagnostic Workflow

Before altering your entire synthesis, use this decision tree to identify the specific failure mode.

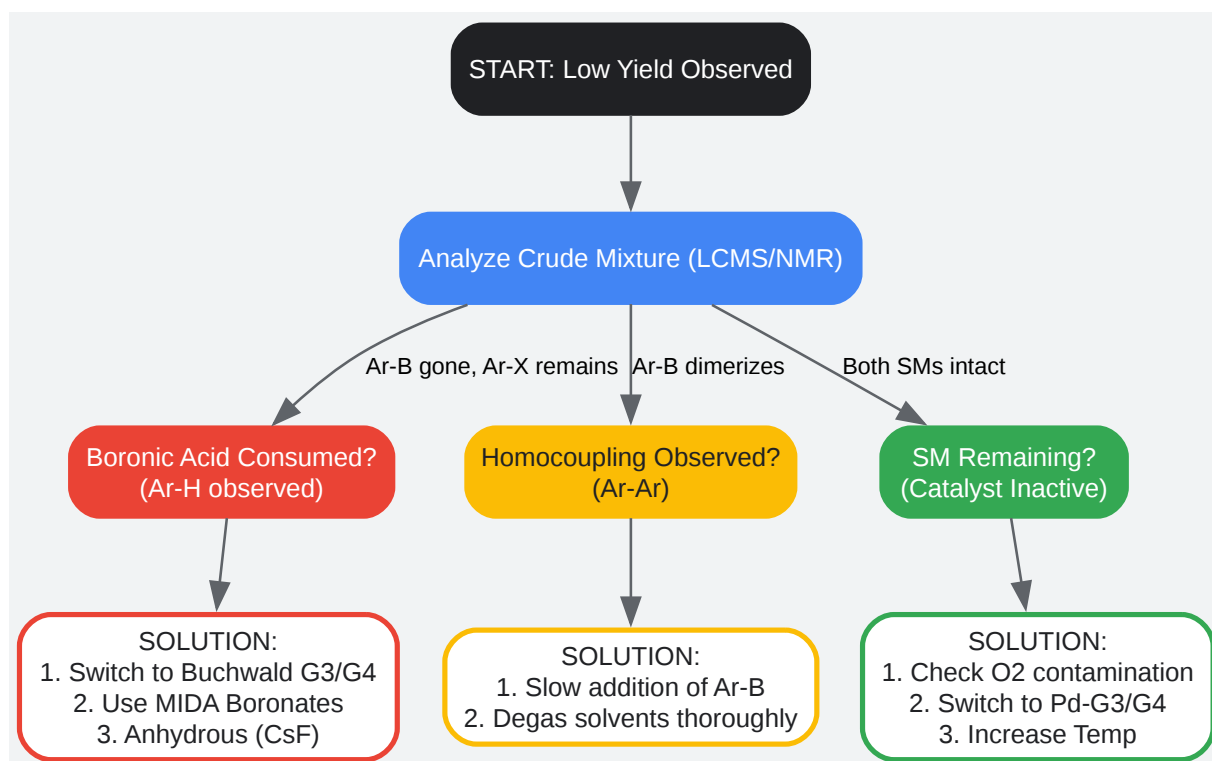

[Click to download full resolution via product page](#)

Figure 1: Diagnostic logic for categorizing Suzuki coupling failure modes.

## The Core Problem: Protodeboronation Mechanism

Understanding why your reaction fails is the key to fixing it. Electron-withdrawing groups (EWGs) make the carbon-boron bond fragile in the presence of base and water.

### The Mechanism of Failure

- Base Attack: Hydroxide or alkoxide attacks the boron to form the "ate" complex (necessary for transmetalation).
- The Fork in the Road: This "ate" complex can either:
  - Path A (Desired): Transmetalate to Palladium.
  - Path B (Undesired): Undergo ipso-protonation and cleave the C-B bond, releasing the arene (Ar-H) and boric acid.

For electron-deficient rings (e.g., 2-pyridyl, C6F5), the negative charge on the "ate" complex is stabilized, making the C-B bond weaker and Path B dominant [1].

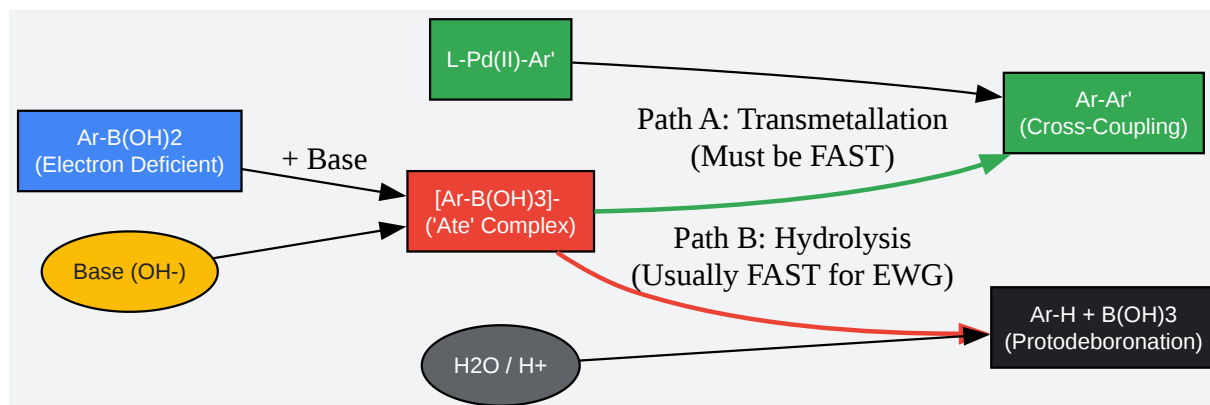

[Click to download full resolution via product page](#)

Figure 2: Kinetic competition between productive transmetalation and destructive protodeboronation.

## Technical Solutions & Optimization

### Strategy A: Catalyst Engineering (The "Speed" Approach)

If the boronic acid decomposes quickly, the catalyst must work faster. You need bulky, electron-rich phosphine ligands that facilitate rapid oxidative addition and create a steric environment that accelerates transmetalation while protecting the active species.

Recommended Ligands:

- XPhos / SPhos: The gold standard for unstable boronic acids. The steric bulk protects the Pd center, and the electron-rich nature drives the catalytic cycle [2].
- Pd-G3/G4 Precatalysts: Use precatalysts (e.g., XPhos Pd G3) to ensure immediate generation of the active Pd(0) species without an induction period where the boronic acid could decompose.

Ligand	Best For	Notes
XPhos	General purpose, heteroaryl chlorides	Excellent for 2-pyridyl and polyfluoroaryl boronates.
SPhos	Sterically hindered partners	High stability; often works where PPh <sub>3</sub> fails.
CataCXium A	Bulky alkyl phosphine	Good alternative for unreactive aryl chlorides.

## Strategy B: Reagent Engineering (The "Slow Release" Approach)

If the "ate" complex is the unstable species, keep its concentration low.[1]

- MIDA Boronates: N-methyliminodiacetic acid (MIDA) protects the boron.[2] Under standard conditions, it slowly hydrolyzes to release the active boronic acid. This "slow release" ensures the active species is consumed by the catalyst immediately upon formation, preventing accumulation and decomposition [3].
- Potassium Organotrifluoroborates (R-BF<sub>3</sub>K): These are air-stable and hydrolyze slowly in the presence of mild base/water to generate the active species.

## Strategy C: Anhydrous Conditions

Eliminate the proton source (water).

- Base: CsF or Potassium Trimethylsilylate (TMSOK).
- Solvent: Anhydrous Dioxane or Toluene.
- Mechanism: Fluoride activates the boronic ester (forming [Ar-B(OR)<sub>2</sub>F]<sup>-</sup>) which can transmetallate but cannot undergo protodeboronation easily because there are no protons available [4].

## Experimental Protocols

## Protocol 1: The "Buchwald" Standard (For moderately unstable acids)

Use this for 2-heterocyclic boronic acids or polyfluorophenyl boronic acids.

- Setup: Charge a vial with Aryl Halide (1.0 equiv), Boronic Acid (1.5 equiv), and XPhos Pd G3 (2-4 mol%).
- Base: Add K<sub>3</sub>PO<sub>4</sub> (3.0 equiv). Note: Phosphate is milder than carbonate and often reduces deboronation.
- Solvent: Add THF/Water (10:1 ratio) or Toluene/Water (10:1). The small amount of water is necessary for the base solubility but keep it minimal.
- Reaction: Degas (sparge with Ar for 5 mins). Seal and heat to 40-60°C.
  - Tip: Do not overheat. Higher temps accelerate deboronation exponentially.

## Protocol 2: MIDA Boronate Coupling (For highly unstable acids)

Use this when Protocol 1 yields <20%.

- Setup: Charge vial with Aryl Halide (1.0 equiv), MIDA Boronate (1.5 equiv), and XPhos Pd G2 (2 mol%).
- Base: Add K<sub>3</sub>PO<sub>4</sub> (7.5 equiv).
- Solvent: Dioxane/Water (5:1).
- Reaction: Heat to 60°C.
  - Mechanism:<sup>[1]</sup><sup>[3]</sup><sup>[4]</sup><sup>[5]</sup><sup>[6]</sup> The water/base slowly hydrolyzes the MIDA backbone, trickling active boronic acid into the cycle.

## Protocol 3: Anhydrous Fluoride Activation (The "Nuclear" Option)

Use this for substrates that decompose instantly in water.

- Setup: Flame-dry glassware. Add Aryl Halide (1.0 equiv), Boronic Acid Pinacol Ester (1.2 equiv), and Pd(PPh<sub>3</sub>)<sub>4</sub> or Pd(dppf)Cl<sub>2</sub> (5 mol%).
- Base: Add CsF (2.0 - 3.0 equiv) or TMSOK (1.5 equiv).
- Solvent: Anhydrous Dioxane or DME.
- Reaction: Heat to 80-100°C under Nitrogen.

## Frequently Asked Questions (FAQ)

Q: My boronic acid disappears in 10 minutes, but no product is formed. Why? A: This is classic protodeboronation. Your boronic acid is hydrolyzing before it can find the palladium.

- Fix: Switch to a MIDA boronate (Strategy B) or use a highly active catalyst like XPhos Pd G3 to speed up the coupling (Strategy A).

Q: Can I just add more boronic acid? A: Yes, "feeding" the reaction is a valid strategy. Add the boronic acid in 3-4 portions over the course of the reaction (e.g., every hour). This mimics the "slow release" of MIDA boronates manually.

Q: Why do you recommend K<sub>3</sub>PO<sub>4</sub> over Na<sub>2</sub>CO<sub>3</sub>? A: Carbonate bases can be too harsh and buffer at a pH that favors deboronation for certain heterocycles. Anhydrous K<sub>3</sub>PO<sub>4</sub> (tribasic potassium phosphate) often provides a better balance of activation vs. decomposition.

Q: I see homocoupling of my aryl halide. What does this mean? A: This usually indicates the catalyst is active (oxidative addition occurred), but transmetallation failed. This confirms your boronic acid is the problem (likely dead/decomposed), leaving the Pd-Ar species to disproportionate or react with itself.

## References

- Cox, P. A., et al. (2016). Protodeboronation of (Hetero)arylboronic Acids. Journal of the American Chemical Society.[2]

- Billingsley, K. L., & Buchwald, S. L. (2008). A New Class of Easily Activated Palladium Precatalysts for Facile C-N Cross-Coupling Reactions and the Low Temperature Oxidative Addition of Aryl Chlorides.[7] *Journal of the American Chemical Society*.[2]
- Knapp, D. M., et al. (2010). MIDA Boronates: A General Solution for Unstable Boronic Acids. *Journal of the American Chemical Society*.[2]
- Kinzel, T., Zhang, Y., & Buchwald, S. L. (2010). A New Palladium Precatalyst Allows for the Fast Suzuki-Miyaura Coupling Reactions of Unstable Polyfluorophenyl and 2-Heteroaryl Boronic Acids.[7] *Journal of the American Chemical Society*.[2]

### Need Custom Synthesis?

BenchChem offers custom synthesis for rare earth carbides and specific isotopic labeling.

Email: [info@benchchem.com](mailto:info@benchchem.com) or [Request Quote Online](#).

## Sources

- [1. Protodeboronation - Wikipedia \[en.wikipedia.org\]](#)
- [2. MIDA Boronates \[sigmaaldrich.com\]](#)
- [3. Yoneda Labs \[yonedalabs.com\]](#)
- [4. Suzuki–Miyaura cross-coupling optimization enabled by automated feedback - Reaction Chemistry & Engineering \(RSC Publishing\) DOI:10.1039/C6RE00153J \[pubs.rsc.org\]](#)
- [5. In Situ Studies of Arylboronic Acids/Esters and R3SiCF3 Reagents: Kinetics, Speciation, and Dysfunction at the Carbanion–Ate Interface - PMC \[pmc.ncbi.nlm.nih.gov\]](#)
- [6. m.youtube.com \[m.youtube.com\]](#)
- [7. 布赫瓦尔德催化剂和配体 \[sigmaaldrich.com\]](#)
- To cite this document: BenchChem. [Technical Support Center: Suzuki Coupling with Electron-Deficient Boronic Acids]. BenchChem, [2026]. [Online PDF]. Available at: [\[https://www.benchchem.com/product/b6304605/docs#technical-support-center-suzuki-coupling-with-electron-deficient-boronic-acids\]](https://www.benchchem.com/product/b6304605/docs#technical-support-center-suzuki-coupling-with-electron-deficient-boronic-acids)

---

### Disclaimer & Data Validity:

The information provided in this document is for Research Use Only (RUO) and is strictly not intended for diagnostic or therapeutic procedures. While BenchChem strives to provide accurate protocols, we make no warranties, express or implied, regarding the fitness of this product for every specific experimental setup.

**Technical Support:** The protocols provided are for reference purposes. Unsure if this reagent suits your experiment?

**Need Industrial/Bulk Grade?** [Request Custom Synthesis Quote](#)

## BenchChem

Our mission is to be the trusted global source of essential and advanced chemicals, empowering scientists and researchers to drive progress in science and industry.

### Contact

Address: 3281 E Guasti Rd  
Ontario, CA 91761, United States  
Phone: (601) 213-4426  
Email: [info@benchchem.com](mailto:info@benchchem.com)

[Contact our Ph.D. Support Team for a compatibility check](#)