

Technical Support Center: High-Polarity Peptide Separation

Author: BenchChem Technical Support Team. **Date:** May 2026

Compound of Interest

Compound Name: *Ac-Arg-NH2 acetate*

CAS No.: *1245401-04-0*

Cat. No.: *B6303742*

[Get Quote](#)

Ticket ID: #ARG-SEP-001 Topic: Resolving Ac-Arg-NH2 vs. Ac-Arg Peaks in HPLC Status: Open / Guide Active

The Core Challenge: Why Standard C18 Fails

Executive Summary: You are attempting to separate two highly polar, hydrophilic molecules that differ only by a single functional group at the C-terminus (Amide vs. Carboxyl).

- Ac-Arg-NH2 (Acetyl-Arginine-Amide): Net charge +1 (Guanidino group) across pH 2–10.
- Ac-Arg (Acetyl-Arginine): Zwitterionic at neutral pH (Net 0); Cationic at pH < 3 (Net +1).

The Failure Mode: In standard Reverse Phase (RP) HPLC at neutral pH, Ac-Arg is too polar to retain on C18. At low pH (pH 2), both molecules carry a +1 charge and have very similar hydrophobicity profiles, leading to co-elution in the void volume or inseparable peak overlap.

Method Selection Guide (Decision Tree)

Do not guess. Use the physicochemical properties of your analytes to dictate the separation mode.^[1]

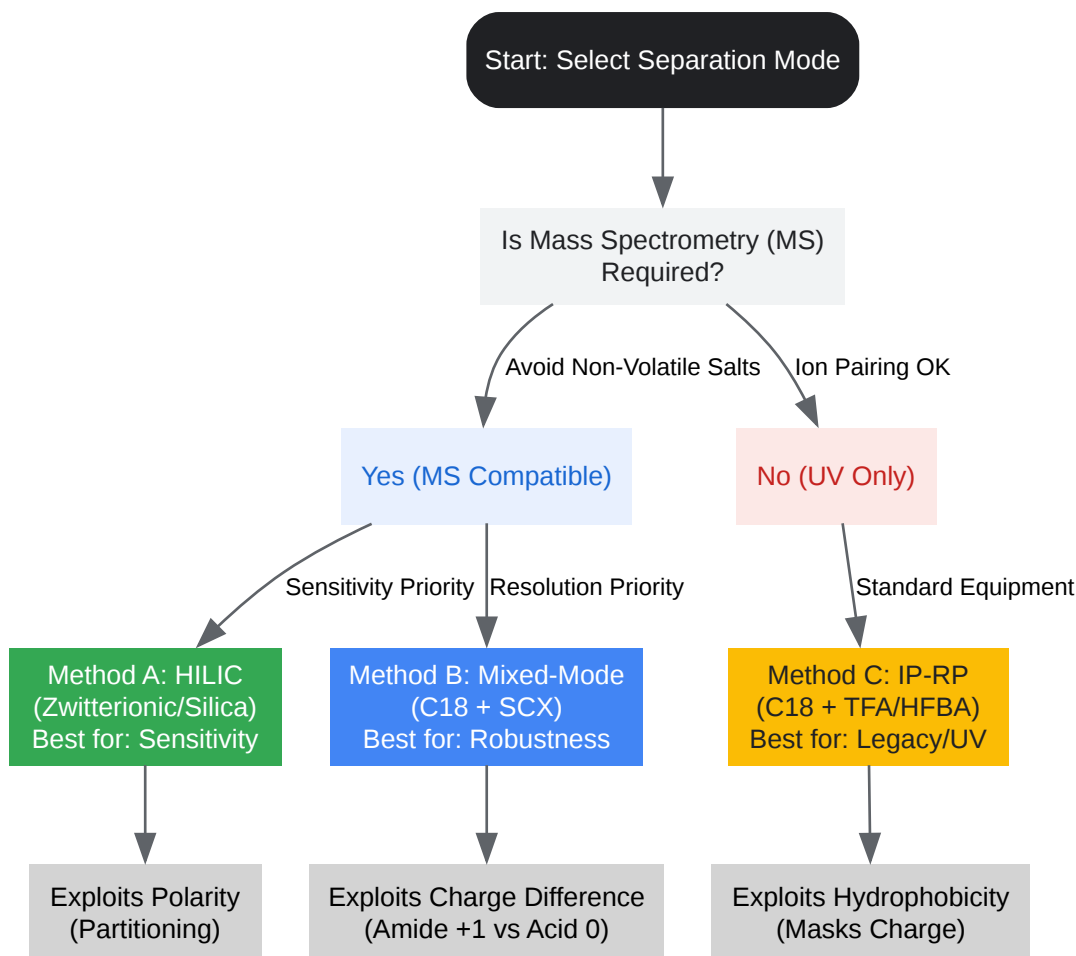

[Click to download full resolution via product page](#)

Figure 1: Decision matrix for selecting the optimal chromatographic mode based on detection requirements.

Recommended Protocols (SOPs)

TIER 1 SOLUTION: Mixed-Mode Chromatography (The "Silver Bullet")

Why it works: This method exploits the charge difference at pH 4–6.

- Ac-Arg (Acid): At pH 5, the C-terminus is deprotonated ($-\text{COO}^-$). The molecule is a zwitterion (Net Charge = 0). It interacts weakly with the cation exchange phase.
- Ac-Arg-NH₂ (Amide): The C-terminus is neutral ($-\text{CONH}_2$). The Guanidino group is positive. Net Charge = +1. It binds strongly to the cation exchange phase.

Parameter	Specification
Column	Mixed-Mode C18/SCX (e.g., SIELC Primesep 100 or Thermo Acclaim Trinity P1)
Mobile Phase A	10 mM Ammonium Acetate, pH 5.0
Mobile Phase B	Acetonitrile (ACN)
Gradient	0–40% B over 15 min
Expected Result	Ac-Arg elutes first (weak retention). Ac-Arg-NH ₂ elutes second (strong retention).
Resolution (Rs)	Typically > 5.0 (Baseline separation)

TIER 2 SOLUTION: HILIC (Hydrophilic Interaction)

Why it works: HILIC retains polar compounds by partitioning them into a water-rich layer on the column surface.^[2]

- Mechanism: The Amide (Ac-Arg-NH₂) is generally more retentive on Zwitterionic phases due to stronger electrostatic interactions compared to the zwitterionic Acid (Ac-Arg).

Parameter	Specification
Column	Zwitterionic HILIC (e.g., Merck SeQuant ZIC-HILIC or Waters BEH Amide)
Mobile Phase A	10 mM Ammonium Formate, pH 3.5 (Aqueous)
Mobile Phase B	Acetonitrile (90%) + 10 mM Ammonium Formate (10%)
Gradient	95% B to 60% B over 20 min (Inverse Gradient)
Sample Diluent	Critical: Must be >80% ACN.[3] Injecting in water causes peak distortion.

Troubleshooting Guide (FAQs)

Issue A: "Both peaks elute in the void volume (t₀)."

Diagnosis: You are likely using a standard C18 column with a low-strength buffer (e.g., 0.1% Formic Acid). Fix:

- Switch to Tier 1 (Mixed-Mode).
- If stuck with C18: You must use an Ion-Pairing agent. Add 0.1% TFA (Trifluoroacetic acid) or 0.05% HFBA (Heptafluorobutyric acid) to Mobile Phase A.
 - Warning: TFA suppresses MS signal. HFBA suppresses it even more.

Issue B: "I see one broad peak with a shoulder."

Diagnosis: Partial separation due to pH mismatch. Fix: Check your pH.

- If using Mixed-Mode: Ensure pH is between 4.5 and 5.5.
 - Too low (< 3): The Acid becomes protonated (+1) and behaves like the Amide (+1). Separation is lost.
 - Too high (> 8): Silica stability issues (unless using polymer-based columns).

Issue C: "My peak shapes are tailing badly."

Diagnosis: Secondary silanol interactions. The positive Guanidino group is sticking to the free silanols on the silica backbone. Fix:

- Increase Buffer Strength: Move from 10 mM to 20–50 mM Ammonium Acetate.
- Temperature: Increase column temperature to 40°C to improve mass transfer kinetics.

Mechanism of Action (Visualized)

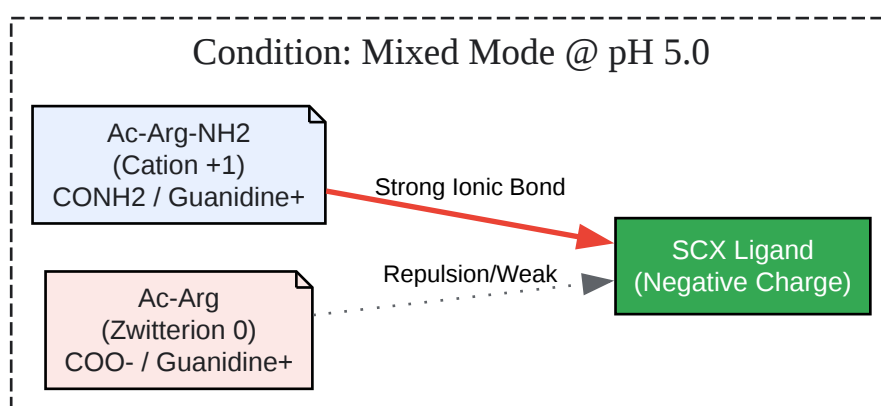

[Click to download full resolution via product page](#)

Figure 2: Mechanistic difference in Mixed-Mode chromatography. At pH 5, the charge disparity drives the separation.

References & Validation

- Mixed-Mode Chromatography Mechanisms:
 - Review: "Effects of Arginine on Multimodal Chromatography." This paper details how arginine interacts with multimodal ligands, validating the charge-based separation strategy. [\[4\]](#)
 - Source:
- HILIC Separation of Polar Peptides:

- Guide: "Retaining and Separating Polar Molecules – When to Use HILIC." Agilent Technical Overview.
- Source:
- Arginine Derivative Separation (ADMA/SDMA):
 - Protocol: "Resolution and quantification of arginine... using HPLC with internal calibration." Demonstrates the necessity of cation exchange for arginine derivatives.
 - Source:
- Ion Pairing (Legacy Methods):
 - Application Note: "HPLC Separation of Arginine Enantiomers." Discusses derivatization and ion-pairing alternatives when direct separation fails.
 - Source:

Need Custom Synthesis?

BenchChem offers custom synthesis for rare earth carbides and specific isotopic labeling.

Email: info@benchchem.com or [Request Quote Online](#).

Sources

- [1. Analytical Methods for Organic Acids : SHIMADZU \(Shimadzu Corporation\)](#) [shimadzu.com]
- [2. documents.thermofisher.com](#) [documents.thermofisher.com]
- [3. researchgate.net](#) [researchgate.net]
- [4. researchgate.net](#) [researchgate.net]
- To cite this document: BenchChem. [Technical Support Center: High-Polarity Peptide Separation]. BenchChem, [2026]. [Online PDF]. Available at: [\[https://www.benchchem.com/product/b6303742/docs#technical-support-center-high-polarity-peptide-separation\]](https://www.benchchem.com/product/b6303742/docs#technical-support-center-high-polarity-peptide-separation)

Disclaimer & Data Validity:

The information provided in this document is for Research Use Only (RUO) and is strictly not intended for diagnostic or therapeutic procedures. While BenchChem strives to provide accurate protocols, we make no warranties, express or implied, regarding the fitness of this product for every specific experimental setup.

Technical Support: The protocols provided are for reference purposes. Unsure if this reagent suits your experiment?

Need Industrial/Bulk Grade? [Request Custom Synthesis Quote](#)

BenchChem

Our mission is to be the trusted global source of essential and advanced chemicals, empowering scientists and researchers to drive progress in science and industry.

Contact

Address: 3281 E Guasti Rd
Ontario, CA 91761, United States
Phone: (601) 213-4426
Email: info@benchchem.com

[Contact our Ph.D. Support Team for a compatibility check](#)