

comparative yield analysis of magnesium bromide vs chloride Grignards

Author: BenchChem Technical Support Team. **Date:** February 2026

Compound of Interest

Compound Name: *2-Ethoxyphenylmagnesium bromide, 0.5 M in THF*

CAS No.: 41842-29-9

Cat. No.: B6302464

[Get Quote](#)

An In-Depth Comparative Analysis for the Synthetic Chemist: Magnesium Bromide vs. Chloride Grignards in Yield and Reactivity

For over a century, Grignard reagents have been a cornerstone of organic synthesis, providing a powerful and versatile method for forming carbon-carbon bonds.[1][2] The reaction of an organic halide with magnesium metal produces a highly reactive organometallic compound, an invaluable tool for researchers in medicinal and materials chemistry.[3][4][5] However, a fundamental choice confronts the chemist at the outset: which halide to use? The selection of an alkyl or aryl chloride versus its bromide counterpart is not merely a matter of availability; it is a critical decision that profoundly influences the reaction's initiation, yield, side-product profile, and even the stereochemical outcome of subsequent reactions.

This guide provides a detailed comparative analysis of magnesium bromide and magnesium chloride Grignards, moving beyond simple reactivity trends to explore the mechanistic nuances and practical considerations that govern their performance. We will examine the causality behind experimental choices, present supporting data, and offer field-proven insights to empower researchers to make the most informed decision for their specific synthetic challenge.

The Halide's Role: A Mechanistic Perspective on Formation

The formation of a Grignard reagent (RMgX) is a heterogeneous reaction occurring on the surface of the magnesium metal.[6] The accepted mechanism involves a single electron transfer (SET) from the magnesium to the antibonding orbital of the carbon-halogen bond of the organic halide (RX).[7][8] This process generates a radical anion which then fragments to form an alkyl or aryl radical and a halide ion, both adsorbed to the magnesium surface, before combining to yield the final organomagnesium halide.[8][9]

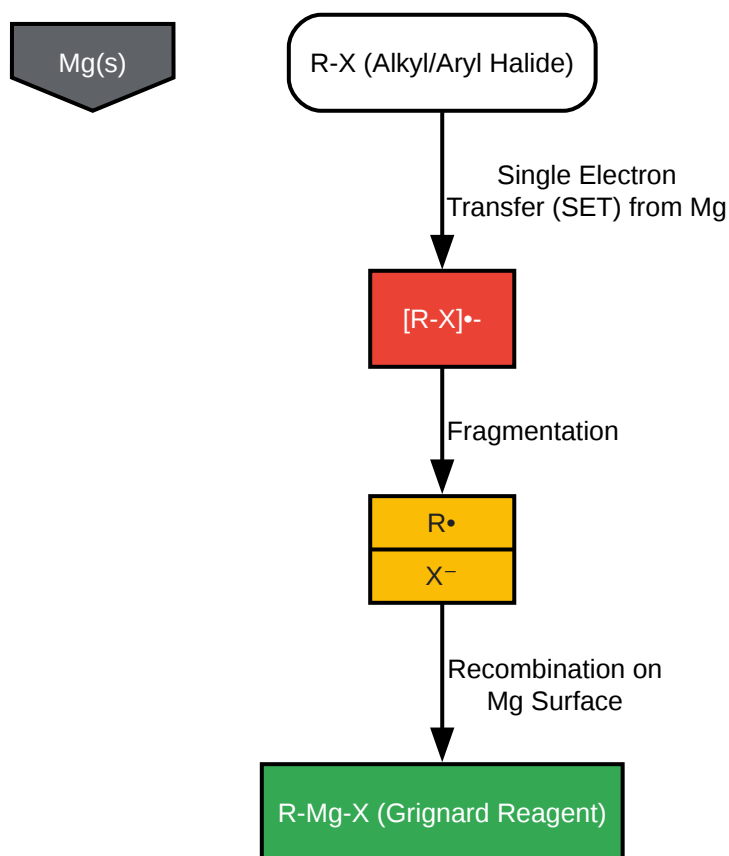

[Click to download full resolution via product page](#)

Caption: Mechanism of Grignard reagent formation via Single Electron Transfer (SET).

The rate-determining step in this sequence is the initial electron transfer, the facility of which is dictated by the strength of the carbon-halogen (C-X) bond.[8][10] Weaker bonds are cleaved more easily, leading to a faster reaction. This fundamental principle establishes the classic reactivity trend for organic halides in Grignard formation:

$R-I > R-Br > R-Cl \gg R-F$ [4][10][11]

Alkyl and aryl fluorides are generally unreactive due to the immense strength of the C-F bond. [10][11] While iodides are the most reactive, their higher cost, lower stability, and propensity for side reactions often make bromides and chlorides the more practical choices for laboratory and industrial applications.

Head-to-Head Comparison: Bromide vs. Chloride Grignards

The choice between using an organic bromide or chloride as a precursor has significant consequences for the entire synthetic workflow, from preparation to the final reaction.

Feature	Magnesium Bromide Grignards (from R-Br)	Magnesium Chloride Grignards (from R-Cl)	Rationale & Causality
C-X Bond Energy	~285 kJ/mol	~340 kJ/mol	The weaker C-Br bond requires less energy to cleave, facilitating easier initiation. [10]
Initiation	Generally rapid and straightforward.	Can be sluggish; often requires activation of Mg or longer induction periods. [10] [12]	The higher C-Cl bond energy presents a larger activation barrier for the initial SET step. [10]
Typical Yield	High (80-90%)	Moderate to High (50-80%+)	While bromides react more readily, chlorides can sometimes lead to higher ultimate yields due to fewer side reactions if initiation is successful. [10] [12]
Cost	More expensive.	Generally more economical.	The industrial processes for chlorination are typically cheaper than bromination. [12]
Wurtz Coupling	Can be a significant side reaction, especially with reactive bromides.	Less prone to Wurtz coupling.	The higher reactivity of R-Br can lead to more coupling with the formed RMgBr (R-MgBr + R-Br → R-R). [1] [6]
Solubility	Generally less soluble in ethereal solvents.	Typically more soluble, especially in THF.	The nature of the Schlenk equilibrium and solvation

complexes differs, with chloride species often exhibiting better solubility.[12]

Lewis Acidity

The Mg center is a stronger Lewis acid.

The Mg center is a weaker Lewis acid.

The more electronegative chlorine atom makes the associated magnesium center less electron-deficient. [12]

Reactivity

Can exhibit different reactivity profiles and stereoselectivity.

Can exhibit different reactivity profiles and stereoselectivity.

The halide atom can remain in the coordination sphere of the magnesium during reaction, influencing the transition state. [13]

Field Insights and Practical Considerations

Initiation is Key: The primary hurdle with alkyl/aryl chlorides is overcoming the activation energy for initiation. While bromides often react with standard magnesium turnings, chlorides may require activation. This can be achieved by adding a small crystal of iodine, a few drops of 1,2-dibromoethane, or by mechanically activating the magnesium by dry-stirring under an inert atmosphere.[6][14]

The Halide Effect in Action: The choice of halide can have subtle but powerful effects on the reactivity of the resulting Grignard reagent. Recent studies have shown a remarkable "halide effect" on the diastereoselectivity of Grignard additions to certain substrates.[13] It is hypothesized that the halide, as part of an intermediate magnesium chelate, influences the electronic properties and conformation of the transition state, thereby directing the incoming nucleophile.[13] This demonstrates that RMgBr and RMgCl are not always interchangeable and that a simple swap can be a powerful tool for stereochemical control.

Economic Viability: For large-scale synthesis, the lower cost of chloro-aromatics often makes them the preferred starting material.^[12] Process chemists frequently invest more effort in developing robust initiation protocols for chlorides to leverage this economic advantage.

Experimental Protocols: A Comparative Workflow

To provide a tangible comparison, we outline a general protocol for the preparation of Phenylmagnesium Bromide and Phenylmagnesium Chloride and their subsequent reaction with a model electrophile, benzophenone.

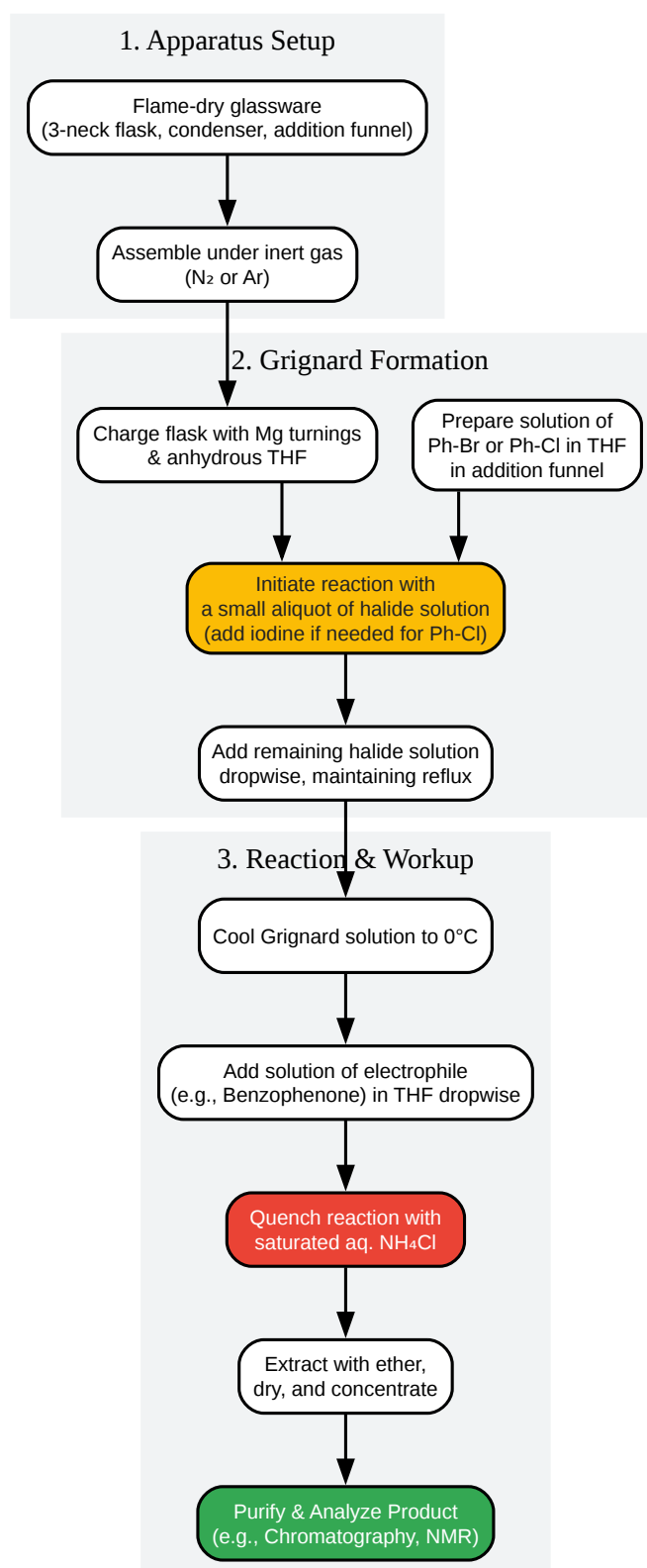

[Click to download full resolution via product page](#)

Caption: Standard experimental workflow for Grignard synthesis and reaction.

Protocol: Comparative Synthesis of Triphenylmethanol

Objective: To compare the yield of triphenylmethanol from the reaction of benzophenone with Phenylmagnesium Bromide vs. Phenylmagnesium Chloride.

Materials:

- Magnesium turnings
- Anhydrous Tetrahydrofuran (THF)
- Bromobenzene (PhBr)
- Chlorobenzene (PhCl)
- Iodine (for initiation, if necessary)
- Benzophenone
- Saturated aqueous ammonium chloride (NH₄Cl)
- Diethyl ether
- Anhydrous magnesium sulfate (MgSO₄)

Procedure:

- Apparatus Setup: A three-necked round-bottom flask is fitted with a reflux condenser, a pressure-equalizing dropping funnel, and a nitrogen/argon inlet. All glassware must be rigorously flame-dried under vacuum and cooled under an inert atmosphere.
- Magnesium Preparation: Charge the flask with magnesium turnings (1.2 equivalents).
- Reagent Preparation: In the dropping funnel, prepare a solution of the aryl halide (1.0 equivalent of either PhBr or PhCl) in anhydrous THF.
- Initiation: Add a small portion (~10%) of the aryl halide solution to the stirring magnesium suspension.^[10]

- For PhBr: Initiation is typically spontaneous, evidenced by gentle bubbling and an exothermic reaction.
- For PhCl: If no reaction is observed after several minutes, add a single small crystal of iodine. Gentle warming with a heat gun may be required to start the reaction.[6]
- Formation: Once initiation is confirmed, add the remaining aryl halide solution dropwise at a rate that maintains a gentle reflux.[10] After the addition is complete, continue to stir the mixture at reflux for an additional 30-60 minutes to ensure complete conversion. The resulting grey, cloudy solution is the Grignard reagent.
- Reaction: Cool the Grignard solution to 0°C in an ice bath. Prepare a solution of benzophenone (0.95 equivalents) in anhydrous THF and add it dropwise to the Grignard reagent.
- Workup: After the addition is complete, allow the reaction to warm to room temperature and stir for 1 hour. Quench the reaction by slowly adding saturated aqueous NH₄Cl.
- Isolation: Extract the aqueous layer with diethyl ether. Combine the organic layers, wash with brine, dry over anhydrous MgSO₄, filter, and concentrate under reduced pressure.
- Analysis: Purify the crude triphenylmethanol by recrystallization or column chromatography. Determine the final mass and calculate the yield. Compare the yields obtained from the PhBr and PhCl routes.

Conclusion and Strategic Recommendations

The decision between using a magnesium bromide or chloride Grignard is a strategic one, balancing reactivity, cost, and experimental feasibility.

- Choose Magnesium Bromide Grignards when:
 - Rapid and reliable initiation is paramount.
 - The starting bromide is readily available and cost is not the primary constraint.
 - Working on a smaller, laboratory scale where ease of formation is prioritized.

- Choose Magnesium Chloride Grignards when:
 - Cost is a major driver, especially in process chemistry and large-scale applications.[\[12\]](#)
 - The corresponding chloride is significantly cheaper or more available than the bromide.
 - Potential side reactions like Wurtz coupling are a concern with the more reactive bromide.
 - You are prepared to invest effort in optimizing the initiation step.

Ultimately, both pathways are synthetically powerful. By understanding the underlying mechanistic principles and practical trade-offs, researchers can harness the full potential of these remarkable reagents, tailoring their approach to achieve the highest possible yield and purity in their unique synthetic endeavors.

References

- Reactions of Alkyl Halides: Grignard Reagents | Organic Chemistry Class Notes - Fiveable. (2025, August 15). Fiveable.
- Mechanism of Grignard Reagent Formation. The Surface Nature of the Reaction. (1978). *Accounts of Chemical Research*, 11(12), 445-451.
- Grignard Reaction: An 'Old-Yet-Gold' synthetic gadget toward the synthesis of natural Products: A review. (2023, November 10). [Source not available].
- 10.6 Reactions of Alkyl Halides: Grignard Reagents - Organic Chemistry | OpenStax. (2023, September 20). OpenStax.
- 10.6: Reactions of Alkyl Halides - Grignard Reagents - Chemistry LibreTexts. (2024, March 24). Chemistry LibreTexts.
- Grignard Reagents For Addition To Aldehydes and Ketones - Master Organic Chemistry. (2011, October 14). Master Organic Chemistry.
- A Review on Grignard Reagent - ResearchGate. (2025, August 6).
- Mechanism of Grignard Reagent Formation - Denmark Group. [Source not available].
- Reactions of Grignard Reagents Reduction of Alkyl Halides. [Source not available].
- The Grignard Reaction Mechanism - Chemistry Steps. (2025, August 5). Chemistry Steps.
- Grignard Reaction - Alfa Chemistry. Alfa Chemistry.
- Grignard Reaction - Organic Chemistry Portal. Organic Chemistry Portal.
- Grignard Reagents: Powerful Tools for Synthesis - Organic Chemistry Academy. (2025, August 2). Organic Chemistry Academy.
- The mechanism of Grignard reaction: finally unravelled - OperaChem. (2024, May 31). OperaChem.

- Formation of Grignard Reagents from Organic Halides. [Source not available].
- The Grignard Reagents | Organometallics - ACS Publications. (2009, March 16).
- A Review on Grignard Reagent - International Journal of Pharmaceutical Sciences and Medicine (IJPSM). (2023, April 15). IJPSM.
- 12.1 Grignard reagents - Organic Chemistry II - Fiveable. (2025, September 15). Fiveable.
- A Grignard reagent is an organomagnesium halide (or R-Mg-X). Explain the difference in the... - Homework.Study.com. Study.com.
- A Comparative Guide to Grignard Reaction Yields with Different Alkyl Halides - Benchchem. BenchChem.
- Grignard reagent - Wikipedia. Wikipedia.
- Magnesium-Halogen Exchange - Andrew G Myers Research Group. Andrew G Myers Research Group.
- Chloride vs. Bromide Grignard Reactivity : r/chemistry - Reddit. (2025, January 17). Reddit.
- Unmasking the halide effect in diastereoselective Grignard reactions applied to C4' modified nucleoside synthesis - PMC. (2025, February 16). PMC.
- Factors Influencing the Course and Mechanisms of Grignard Reactions. XI. The Effect of Metallic Halides on the Reaction of Grign. [Source not available].
- Grignard Reaction Reagents: A Toolbox for Chemists. (2024, September 19). [Source not available].
- Grignard reagents | Geology | Research Starters - EBSCO. EBSCO.
- Generation of Aryl and Heteroaryl Magnesium Reagents in Toluene by Br/Mg or Cl/Mg Exchange - PubMed. (2018, May 28). PubMed.
- Grignard Formation - Troubleshooting and Perfecting : r/Chempros - Reddit. (2021, September 9). Reddit.
- grignard reagents - Chemguide. Chemguide.
- Organometallic compound - Stability, Reactivity, Bonding - Britannica. Britannica.
- 6.4 Reactions of Alkyl Halides: Grignard Reagents – Fundamentals of Organic Chemistry. [Source not available].
- A LiCl-Mediated Br/Mg Exchange Reaction for the Preparation of Functionalized Aryl- and Heteroarylmagnesium Compounds from Organic Bromides. [Source not available].
- Organomagnesium Based Flash Chemistry: Continuous Flow Generation and Utilization of Halomethylmagnesium Intermedi
- Summary of Organometallic Coupling Reagents and Reaction Partners - YouTube. (2018, January 26). YouTube.
- Reactions of Organomagnesates and Aryl Halides: Metalation and Nucleophilic Substitution | Request PDF - ResearchGate. (2026, January 24).
- pounds.[1–3] Allylic Grignard reagents. [Source not available].

- THE HALOGEN/MAGNESIUM-EXCHANGE USING $i\text{PrMgCl}\cdot\text{LiCl}$ AND RELATED EXCHANGE REAGENTS Nadja M. Barl, Veronika Werner, Christoph Säma - LOCKSS: Serve Content. (2013, October 1). LOCKSS.
- US3426087A - Method for the preparation of grignard compounds in hydrocarbon solution - Google Patents.

Need Custom Synthesis?

BenchChem offers custom synthesis for rare earth carbides and specific isotopic labeling.

Email: info@benchchem.com or [Request Quote Online](#).

Sources

- [1. Grignard Reagents: Powerful Tools for Synthesis – Organic Chemistry Academy \[ochemacademy.com\]](#)
- [2. pubs.acs.org \[pubs.acs.org\]](#)
- [3. Grignard Reaction: An 'Old-Yet-Gold' synthetic gadget toward the synthesis of natural Products: A review - Arabian Journal of Chemistry \[arabjchem.org\]](#)
- [4. chem.libretexts.org \[chem.libretexts.org\]](#)
- [5. researchgate.net \[researchgate.net\]](#)
- [6. alfa-chemistry.com \[alfa-chemistry.com\]](#)
- [7. denmarkgroup.web.illinois.edu \[denmarkgroup.web.illinois.edu\]](#)
- [8. Formation of Grignard Reagents from Organic Halides \[research.cm.utexas.edu\]](#)
- [9. web.alfredstate.edu \[web.alfredstate.edu\]](#)
- [10. pdf.benchchem.com \[pdf.benchchem.com\]](#)
- [11. 10.6 Reactions of Alkyl Halides: Grignard Reagents - Organic Chemistry | OpenStax \[openstax.org\]](#)
- [12. reddit.com \[reddit.com\]](#)
- [13. Unmasking the halide effect in diastereoselective Grignard reactions applied to C4' modified nucleoside synthesis - PMC \[pmc.ncbi.nlm.nih.gov\]](#)
- [14. masterorganicchemistry.com \[masterorganicchemistry.com\]](#)

- To cite this document: BenchChem. [comparative yield analysis of magnesium bromide vs chloride Grignards]. BenchChem, [2026]. [Online PDF]. Available at: [<https://www.benchchem.com/product/b6302464#comparative-yield-analysis-of-magnesium-bromide-vs-chloride-grignards>]

Disclaimer & Data Validity:

The information provided in this document is for Research Use Only (RUO) and is strictly not intended for diagnostic or therapeutic procedures. While BenchChem strives to provide accurate protocols, we make no warranties, express or implied, regarding the fitness of this product for every specific experimental setup.

Technical Support: The protocols provided are for reference purposes. Unsure if this reagent suits your experiment? [[Contact our Ph.D. Support Team for a compatibility check](#)]

Need Industrial/Bulk Grade? [Request Custom Synthesis Quote](#)

BenchChem

Our mission is to be the trusted global source of essential and advanced chemicals, empowering scientists and researchers to drive progress in science and industry.

Contact

Address: 3281 E Guasti Rd
Ontario, CA 91761, United States
Phone: (601) 213-4426
Email: info@benchchem.com