

Technical Support Center: Oxetane Handling & Stability Guide

Author: BenchChem Technical Support Team. **Date:** April 2026

Compound of Interest

Compound Name: 3-(Iodomethyl)-3-methoxy-oxetane

CAS No.: 2306276-37-7

Cat. No.: B6300532

[Get Quote](#)

Ticket ID: OX-STAB-2024 Subject: Preventing Polymerization of Oxetane Building Blocks
Assigned Specialist: Dr. A. Vance, Senior Application Scientist Status: Open[1]

Introduction: The "Hidden Killer" in Oxetane Chemistry

Welcome to the Oxetane Technical Support Center. You are likely here because you have observed a common but frustrating phenomenon: your oxetane starting material—valuable for its ability to lower lipophilicity and improve metabolic stability—has converted into an insoluble white solid or a viscous gum during synthesis or purification.[1]

This is not a random degradation; it is Cationic Ring-Opening Polymerization (CROP).[1] Oxetanes are structurally unique; they possess high ring strain (~107 kJ/mol) similar to epoxides, but their oxygen lone pairs are significantly more basic (pKa of conjugate acid ≈ -2.0) compared to epoxides (≈ -3.7).[1] This makes them "goldilocks" electrophiles: stable enough for many biological assays, yet highly susceptible to acid-catalyzed polymerization during chemical manipulation.[1]

This guide provides the protocols required to arrest this mechanism and preserve your material.

Part 1: The Mechanism (Know Your Enemy)

Q: Why did my flask turn into a brick?

A: You likely exposed your oxetane to a Lewis or Brønsted acid without a nucleophilic "exit strategy."^[1]

The polymerization of oxetane is autocatalytic in the presence of acid. Once a single oxetane oxygen is protonated (or coordinated to a Lewis Acid), it becomes a potent electrophile. If no specific nucleophile is present to intercept it, a second molecule of neutral oxetane acts as the nucleophile, attacking the ring. This opens the first ring and transfers the positive charge to the new terminal oxygen, creating a chain reaction.

The CROP Pathway

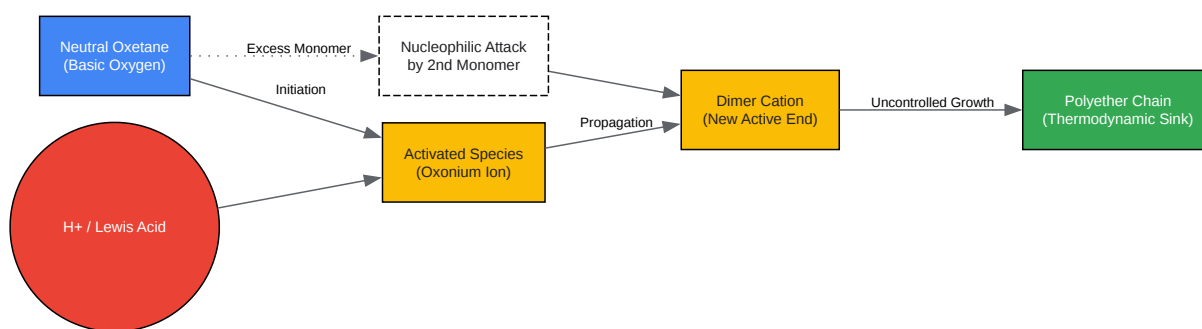

[Click to download full resolution via product page](#)

Figure 1: Mechanism of Cationic Ring-Opening Polymerization (CROP).^{[1][2]} Note that the reaction is driven by the relief of ring strain and propagated by the transfer of the oxonium ion.

Part 2: Synthesis & Reaction Optimization

Q: Can I use Lewis Acids (e.g., for Friedel-Crafts) without polymerizing the starting material?

A: Yes, but you must differentiate between "Hard" and "Soft" activation and control the temperature strictly.

Strong, hard Lewis acids (e.g.,

) coordinate tightly to the oxetane oxygen, maximizing the inductive effect that weakens the C-O bond. If the intended nucleophile (e.g., an arene) is sluggish, the oxetane itself will compete as the nucleophile.

Troubleshooting Protocol: Lewis Acid Activation

Parameter	Recommendation	Scientific Rationale
Lewis Acid Choice	Prefer or over .	Modulates the "hardness" of the activation. is often too aggressive for sensitive oxetanes.[1]
Temperature	-78 °C to -20 °C	Low temperature kinetically favors the bimolecular reaction with the intended nucleophile over the entropy-driven polymerization.[1]
Addition Order	Add Acid Last (slowly).	Ensure the oxetane is surrounded by the intended nucleophile before activation occurs.
Quench	Triethylamine () / MeOH	Immediately neutralize the active species before warming the reaction mixture.[1]

Part 3: Workup & Purification (The Danger Zone)

Q: My crude NMR looked perfect, but I lost everything on the silica column. What happened?

A: Standard silica gel is acidic (pH ~4–5 in aqueous slurry).[1] This is sufficient to initiate polymerization of oxetanes during the time-scale of flash chromatography.[1]

The Fix: You must chemically modify the stationary phase to mask acidic silanol groups.[1]

Protocol: Deactivated Silica Gel Chromatography[1]

This is the single most effective intervention for oxetane preservation.[1]

Step 1: The Pre-Wash

- Pack your column with standard silica gel.[1]
- Prepare a "Deactivation Eluent": 99% Hexanes / 1% Triethylamine ().[1]
- Flush the column with 3–4 column volumes (CV) of this mixture.
 - Why? The coordinates to the acidic Si-OH sites, creating a basic buffer layer.

Step 2: The Elution

- Switch to your separation solvent system (e.g., Hexanes/Ethyl Acetate).[1]
- Crucial: Maintain 1% in the eluent throughout the entire run.
 - Note: Oxetanes are polar; they often streak.[1] The amine additive sharpens the peak shape by preventing "drag" on acidic sites.

Step 3: Post-Column

- Evaporate solvents at bath temperature < 40 °C.

- If

remains, it can be removed via high vacuum or an azeotrope with heptane; however, trace is often preferred for storage stability.[1]

Purification Decision Logic

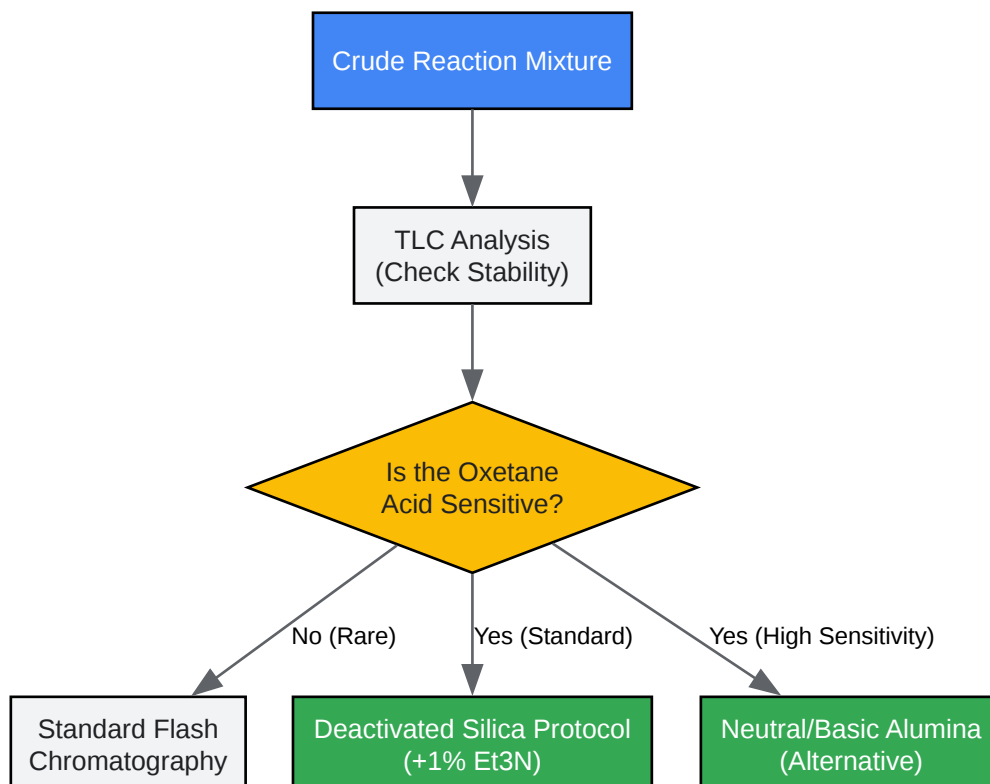

[Click to download full resolution via product page](#)

Figure 2: Decision tree for selecting the appropriate stationary phase to prevent on-column degradation.

Part 4: Storage & Handling

Q: Can I store oxetanes in the fridge?

A: Yes, but moisture and

are risks.[1]

Chloroform (

) is a particularly dangerous solvent for storage because it slowly decomposes to form phosgene and HCl upon exposure to light and air.[1] This trace HCl is enough to polymerize an oxetane sample in a freezer over a weekend.[1]

Storage Best Practices Table

Factor	Guideline	Mechanism of Failure
Solvent	Store neat or in Benzene/Toluene. Avoid or for long periods.[1]	Halogenated solvents can generate trace acid (HCl) over time.[1]
Stabilizer	Add solid pellets to the vial.	Acts as a scavenger for any adventitious acid or moisture. [1]
Atmosphere	Argon/Nitrogen flush.[1]	+ Carbonic acid (weak, but potentially catalytic).
Temperature	-20 °C	Slows down kinetics of any initiation events.[1]

References

- Wurts, J. et al. (2010).[1] "Oxetanes as Promising Modules in Drug Discovery." [1][3][4][5] Journal of Medicinal Chemistry. [\[Link\]](#)
- Bull, J. A. et al. (2016).[1][6][7] "Oxetanes: Recent Advances in Synthesis, Reactivity, and Medicinal Chemistry." [4][5][6][7][8][9] Chemical Reviews. [\[Link\]](#)[4][7]
- Burkhard, J. A., et al. (2010).[1] "Synthesis and Structural Analysis of 3,3-Disubstituted Oxetanes." European Journal of Organic Chemistry. [\[Link\]](#)

Need Custom Synthesis?

BenchChem offers custom synthesis for rare earth carbides and specific isotopic labeling.

Email: info@benchchem.com or [Request Quote Online](#).

Sources

- [1. Oxetanes - Enamine \[enamine.net\]](#)
- [2. researchgate.net \[researchgate.net\]](#)
- [3. Oxetanes in drug discovery: structural and synthetic insights - PubMed \[pubmed.ncbi.nlm.nih.gov\]](#)
- [4. \(PDF\) Oxetanes: Recent Advances in Synthesis, Reactivity, and Medicinal Chemistry \[academia.edu\]](#)
- [5. pubs.acs.org \[pubs.acs.org\]](#)
- [6. Oxetanes: Recent Advances in Synthesis, Reactivity, and Medicinal Chemistry - PubMed \[pubmed.ncbi.nlm.nih.gov\]](#)
- [7. researchgate.net \[researchgate.net\]](#)
- [8. BJOC - Oxetanes: formation, reactivity and total syntheses of natural products \[beilstein-journals.org\]](#)
- [9. chemrxiv.org \[chemrxiv.org\]](#)
- To cite this document: BenchChem. [Technical Support Center: Oxetane Handling & Stability Guide]. BenchChem, [2026]. [Online PDF]. Available at: [\[https://www.benchchem.com/product/b6300532/docs#technical-support-center-oxetane-handling-stability-guide\]](https://www.benchchem.com/product/b6300532/docs#technical-support-center-oxetane-handling-stability-guide)

Disclaimer & Data Validity:

The information provided in this document is for Research Use Only (RUO) and is strictly not intended for diagnostic or therapeutic procedures. While BenchChem strives to provide accurate protocols, we make no warranties, express or implied, regarding the fitness of this product for every specific experimental setup.

Technical Support: The protocols provided are for reference purposes. Unsure if this reagent suits your experiment?

Need Industrial/Bulk Grade? [Request Custom Synthesis Quote](#)

BenchChem

Our mission is to be the trusted global source of essential and advanced chemicals, empowering scientists and researchers to drive progress in science and industry.

Contact

Address: 3281 E Guasti Rd
Ontario, CA 91761, United States
Phone: (601) 213-4426
Email: info@benchchem.com

[Contact our Ph.D. Support Team for a compatibility check](#)