

Application Notes and Protocols for In Vitro Thrombosis Assays of Dabigatran Etexilate

Author: BenchChem Technical Support Team. **Date:** December 2025

Compound of Interest

Compound Name: *Dabigatran etexilate*

Cat. No.: *B6300286*

[Get Quote](#)

For Researchers, Scientists, and Drug Development Professionals

These application notes provide an overview and detailed protocols for assessing the in vitro antithrombotic effects of dabigatran, the active metabolite of the prodrug **dabigatran etexilate**. Dabigatran is a potent, selective, and reversible direct thrombin inhibitor. Its primary mechanism of action is the direct blockage of the active site of thrombin, thereby inhibiting both free and fibrin-bound thrombin.[1] This document outlines key in vitro assays to characterize its anticoagulant and antiplatelet activity.

Key In Vitro Assays for Dabigatran

Several key assays are utilized to evaluate the efficacy of dabigatran in vitro. These include:

- **Clotting Assays:** Activated partial thromboplastin time (aPTT), prothrombin time (PT), and ecarin clotting time (ECT) are fundamental tests to assess the anticoagulant effect of dabigatran on the coagulation cascade.[2]
- **Thrombin Generation Assay (TGA):** This assay measures the endogenous thrombin potential (ETP), providing a comprehensive assessment of the overall coagulation potential in plasma. [2]
- **Platelet Aggregation Assays:** These assays evaluate the inhibitory effect of dabigatran on thrombin-induced platelet aggregation.[2][3]

- Thromboelastography (TEG) / Rotational Thromboelastometry (ROTEM): These whole blood assays provide a global assessment of hemostasis, including clot formation, strength, and lysis.[4][5]

Clotting Assays

Application:

To determine the concentration-dependent anticoagulant effects of dabigatran in human plasma.

Protocol: Activated Partial Thromboplastin Time (aPTT)

- Sample Preparation: Prepare platelet-poor plasma (PPP) by centrifuging citrated whole blood.
- Reagent Preparation: Reconstitute aPTT reagent according to the manufacturer's instructions.
- Assay Procedure:
 - Pre-warm the PPP sample and aPTT reagent to 37°C.
 - Mix equal volumes of PPP and aPTT reagent in a coagulometer cuvette and incubate for the time specified by the reagent manufacturer.
 - Add pre-warmed calcium chloride solution to initiate clotting.
 - The coagulometer will measure the time until clot formation.
- Data Analysis: Record the clotting time in seconds. A doubling of the aPTT indicates a significant anticoagulant effect.

Data Summary:

Assay	Dabigatran Concentration for Doubling of Clotting Time (in human PPP)
aPTT	0.23 μM [2]
PT	0.83 μM [2]
ECT	0.18 μM [2]

Thrombin Generation Assay (TGA)

Application:

To measure the inhibitory effect of dabigatran on the total amount of thrombin generated in plasma.

Protocol: Calibrated Automated Thrombogram (CAT)

- Sample Preparation: Use platelet-poor plasma (PPP).
- Reagent Preparation: Prepare a reagent mixture containing a thrombin substrate and a trigger (e.g., tissue factor).
- Assay Procedure:
 - Pipette PPP into a 96-well plate.
 - Add varying concentrations of dabigatran to the wells.
 - Dispense the reagent mixture to start the reaction.
 - The plate is read in a fluorometer at 37°C.
- Data Analysis: The software calculates the endogenous thrombin potential (ETP), which is the area under the thrombin generation curve. The IC50 is the concentration of dabigatran that inhibits 50% of the ETP.

Data Summary:

Assay	Parameter	IC50 of Dabigatran
Thrombin Generation	Endogenous Thrombin Potential (ETP)	0.56 μ M[2]

Platelet Aggregation Assay

Application:

To assess the ability of dabigatran to inhibit thrombin-induced platelet aggregation. Dabigatran does not inhibit platelet aggregation induced by other agonists like collagen or ADP.[6]

Protocol: Light Transmission Aggregometry (LTA)

- Sample Preparation: Prepare platelet-rich plasma (PRP) from citrated whole blood.
- Assay Procedure:
 - Place a cuvette with PRP in the aggregometer and stir at 37°C.
 - Add dabigatran at various concentrations and incubate.
 - Add a thrombin solution to induce aggregation. To prevent fibrin polymerization which can interfere with the reading, the peptide Gly-Pro-Arg-Pro (GPRP) can be added.[3]
 - The instrument measures the change in light transmission as platelets aggregate.
- Data Analysis: The maximum aggregation percentage is recorded. The IC50 is the concentration of dabigatran that inhibits 50% of thrombin-induced platelet aggregation.

Data Summary:

Agonist	Parameter	IC50 of Dabigatran
Thrombin	Platelet Aggregation	10 nM[2]
Thrombin (0.5 U/mL)	Platelet Aggregation	10.5 nM[3]
Thrombin (1.0 U/mL)	Platelet Aggregation	40.4 nM[3]

Thromboelastography (TEG) / Rotational Thromboelastometry (ROTEM)

Application:

To evaluate the global hemostatic function in the presence of dabigatran using whole blood.

Protocol: Kaolin-activated TEG

- Sample Preparation: Use fresh citrated whole blood.
- Assay Procedure:
 - Add whole blood to a cuvette containing kaolin as an activator.
 - Place the cuvette in the TEG analyzer.
 - The instrument measures the viscoelastic changes during clot formation and lysis.
- Data Analysis: Key parameters to analyze are the R-time (reaction time), K-time (kinetics), alpha-angle, and maximum amplitude (MA). Dabigatran is expected to prolong the R-time.

Data Summary:

Assay	Parameter	Effect of Dabigatran
TEG/ROTEM	R-time (Clotting Time)	Prolonged in a dose-dependent manner[4][7]
TEG/ROTEM	Maximum Clot Firmness (MCF)	Correlates with dabigatran concentrations[4]

Visualizations

Signaling Pathway of Dabigatran's Action

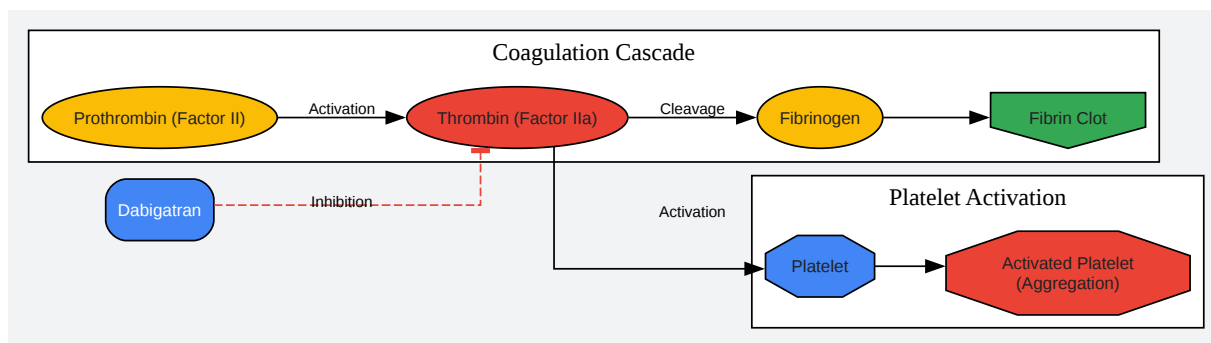

[Click to download full resolution via product page](#)

Caption: Mechanism of action of dabigatran.

Experimental Workflow for In Vitro Thrombosis Assay

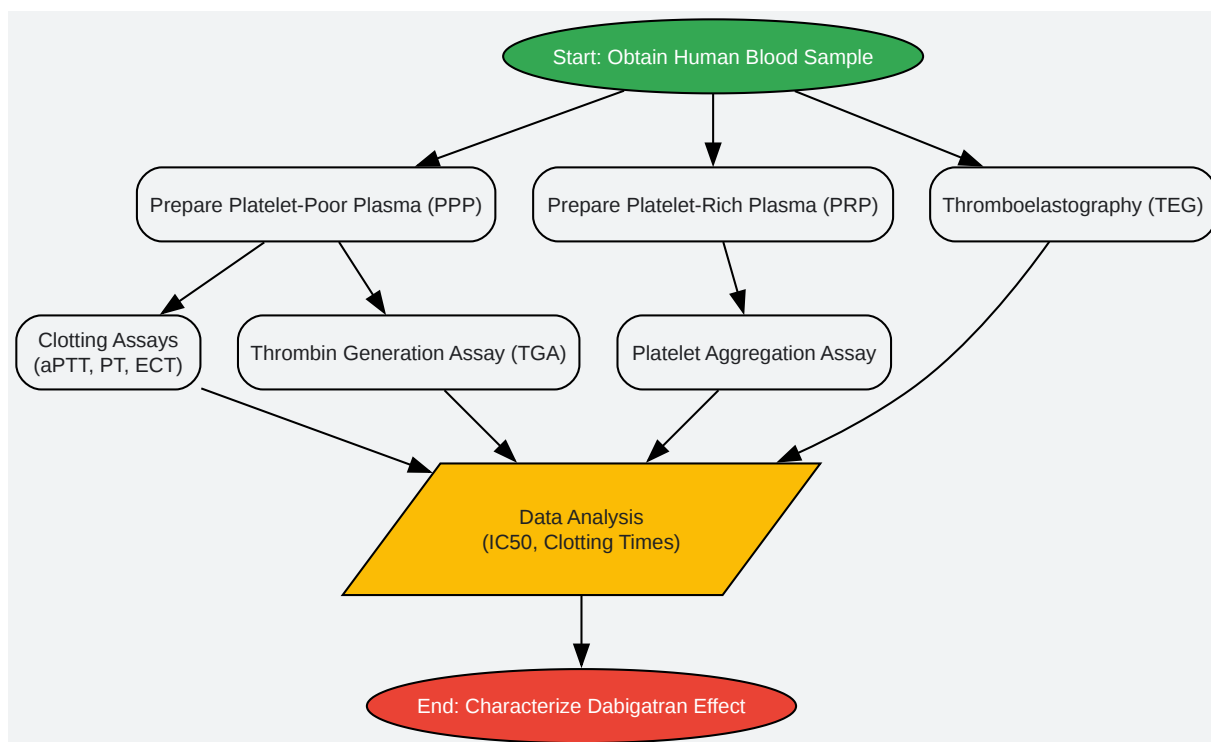

[Click to download full resolution via product page](#)

Caption: General workflow for in vitro evaluation of dabigatran.

Logical Relationship of Dabigatran's Effects

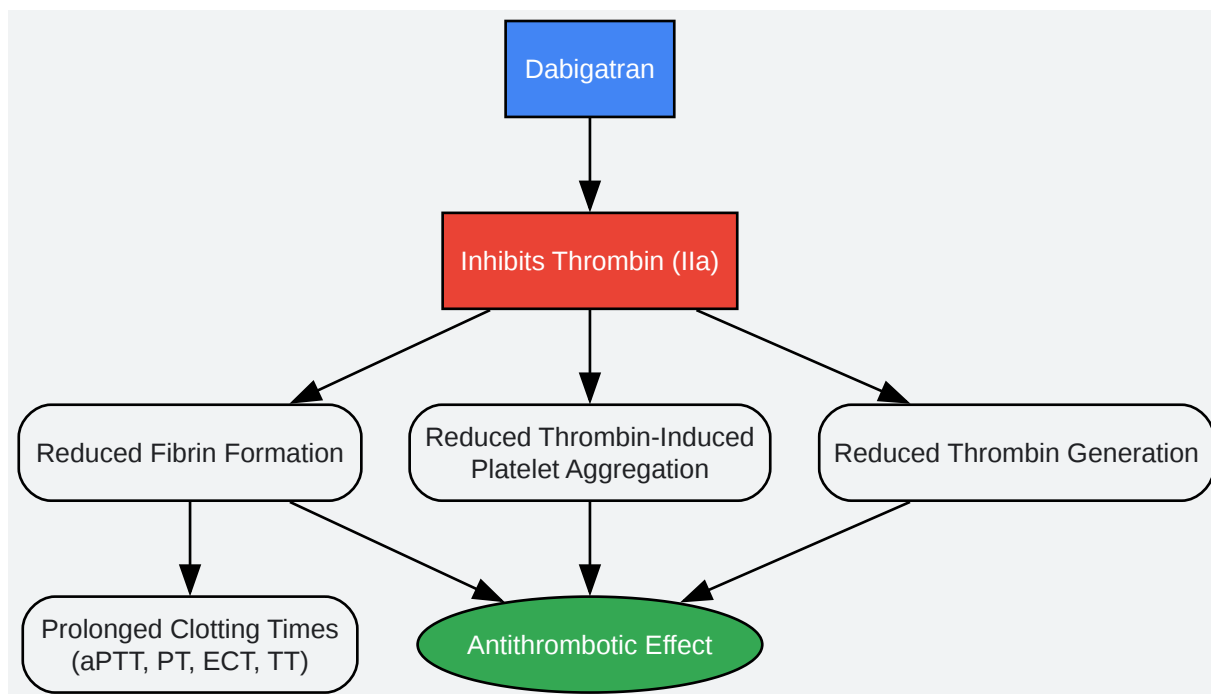

[Click to download full resolution via product page](#)

Need Custom Synthesis?

BenchChem offers custom synthesis for rare earth carbides and specific isotopic labeling.

Email: info@benchchem.com or [Request Quote Online](#).

References

- 1. Dabigatran Attenuates the Binding of Thrombin to Platelets—A Novel Mechanism of Action - PMC [pmc.ncbi.nlm.nih.gov]
- 2. In-vitro profile and ex-vivo anticoagulant activity of the direct thrombin inhibitor dabigatran and its orally active prodrug, dabigatran etexilate - PubMed [pubmed.ncbi.nlm.nih.gov]
- 3. Thrombin-induced platelet aggregation -effect of dabigatran using automated platelet aggregometry - PubMed [pubmed.ncbi.nlm.nih.gov]

- 4. Impact of Dabigatran Treatment on Rotation Thromboelastometry - PMC [pmc.ncbi.nlm.nih.gov]
- 5. litfl.com [litfl.com]
- 6. Dabigatran reduces thrombin-induced platelet aggregation and activation in a dose-dependent manner - PubMed [pubmed.ncbi.nlm.nih.gov]
- 7. researchgate.net [researchgate.net]
- To cite this document: BenchChem. [Application Notes and Protocols for In Vitro Thrombosis Assays of Dabigatran Etexilate]. BenchChem, [2025]. [Online PDF]. Available at: [https://www.benchchem.com/product/b6300286#dabigatran-etexilate-in-vitro-thrombosis-assay-protocols]

Disclaimer & Data Validity:

The information provided in this document is for Research Use Only (RUO) and is strictly not intended for diagnostic or therapeutic procedures. While BenchChem strives to provide accurate protocols, we make no warranties, express or implied, regarding the fitness of this product for every specific experimental setup.

Technical Support: The protocols provided are for reference purposes. Unsure if this reagent suits your experiment? [[Contact our Ph.D. Support Team for a compatibility check](#)]

Need Industrial/Bulk Grade? [Request Custom Synthesis Quote](#)

BenchChem

Our mission is to be the trusted global source of essential and advanced chemicals, empowering scientists and researchers to drive progress in science and industry.

Contact

Address: 3281 E Guasti Rd
Ontario, CA 91761, United States
Phone: (601) 213-4426
Email: info@benchchem.com