

# Technical Guide: Spectroscopic Profiling of 6-(Dimethoxymethyl)-2-mercaptonicotinonitrile

**Author:** BenchChem Technical Support Team. **Date:** May 2026

## Compound of Interest

Compound Name: 6-(Dimethoxymethyl)-2-mercaptonicotinonitrile

CAS No.: 175277-23-3

Cat. No.: B063809

[Get Quote](#)

## Executive Summary

Compound: **6-(Dimethoxymethyl)-2-mercaptonicotinonitrile** CAS Registry Number: 175277-23-3 Molecular Formula:

Molecular Weight: 210.25 g/mol

This guide provides a comprehensive reference for the identification and quality control of **6-(Dimethoxymethyl)-2-mercaptonicotinonitrile**. This compound is a critical heterocyclic intermediate, primarily utilized in the synthesis of kinase inhibitors and agrochemicals. Its structural integrity relies on the stability of the acetal moiety at the C6 position and the tautomeric equilibrium of the 2-mercapto/thione group.

## Structural Dynamics & Tautomerism

Understanding the tautomeric state is a prerequisite for accurate spectral interpretation. In solution (particularly in polar aprotic solvents like DMSO-

), the compound predominantly exists in the thione form (pyridin-2(1H)-thione) rather than the thiol form.

## Tautomeric Equilibrium

- Solid State/Polar Solvent: Thione form (favored). Characterized by a thioamide-like proton (-H) and a character.
- Basic Conditions/S-Alkylation: Thiolate anion (favored).

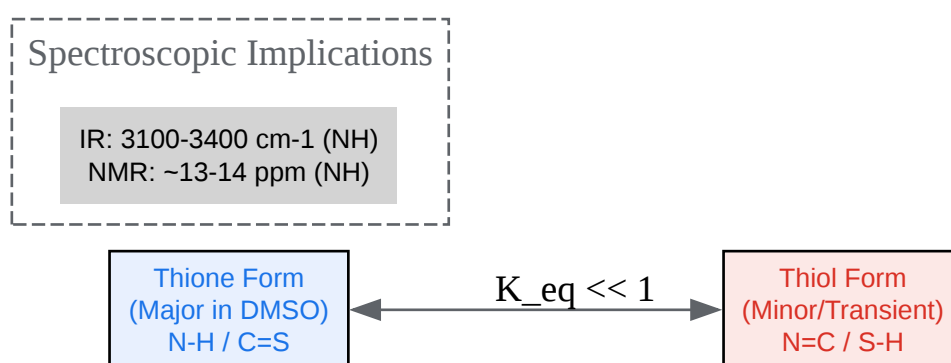

[Click to download full resolution via product page](#)

Figure 1: Tautomeric equilibrium favoring the thione form in polar media, critical for NMR assignment.

## Synthesis & Sample Preparation

To ensure spectral fidelity, the sample must be prepared free of the common hydrolysis byproduct (6-formyl derivative).

### Synthesis Pathway (Enaminone Route)

The most robust synthesis involves the cyclocondensation of an acetal-protected enaminone with 2-cyanothioacetamide.

- Precursor Formation: Reaction of 1,1-dimethoxypropan-2-one with DMF-DMA yields 4-(dimethylamino)-1,1-dimethoxy-3-buten-2-one.

- Cyclization: The enaminone reacts with 2-cyanothioacetamide in the presence of sodium alkoxide.
- Acidification: Careful neutralization precipitates the product while preserving the acid-sensitive acetal group.

## Analytical Sample Preparation

- NMR Solvent: DMSO-

(99.9% D) is required. CDCl

is often insufficient due to poor solubility of the thione form.

- Handling: Avoid prolonged exposure to aqueous acid to prevent deprotection of the dimethoxymethyl group to the aldehyde.

## Spectroscopic Data Specifications

### Nuclear Magnetic Resonance ( <sup>1</sup>H & <sup>13</sup>C NMR)

Data reflects the thione tautomer in DMSO-

.

Table 1:

<sup>1</sup>H NMR Assignments (400 MHz, DMSO-

)

Position	Shift ( , ppm)	Multiplicity	Integration	Coupling ( , Hz)	Assignment Logic
NH	13.80 - 14.20	Broad Singlet	1H	-	Thioamide proton (deshielded).
H-4	8.15 - 8.25	Doublet	1H	8.0	Deshielded by adjacent CN group (anisotropy).
H-5	6.90 - 7.05	Doublet	1H	8.0	Shielded relative to H-4; typical for pyridine -proton.
Acetal CH	5.25 - 5.35	Singlet	1H	-	Methine proton of the acetal group.
OMe	3.35 - 3.45	Singlet	6H	-	Two equivalent methoxy groups.

Table 2:

C NMR Assignments (100 MHz, DMSO-

)

Carbon Type	Shift ( , ppm)	Assignment
C=S	178.5	C-2 (Thione carbon, highly deshielded).
C-6	154.2	Quaternary C attached to acetal.
C-4	142.8	Aromatic CH.
CN	116.5	Nitrile carbon.
C-5	108.3	Aromatic CH.
C-3	105.1	Quaternary C (C-CN).
Acetal CH	100.5	Characteristic acetal methine.
OMe	53.8	Methoxy carbons.

## Infrared Spectroscopy (FT-IR)

The IR spectrum confirms the functional groups, specifically distinguishing the nitrile and the thione/thioamide state.

- Nitrile ( ): Sharp, strong band at 2220–2230 cm .
- Amine/Amide ( ): Broad band at 3100–3250 cm (indicative of the thione tautomer hydrogen bonded network).
- Thione ( ): Characteristic absorptions in the fingerprint region, often around 1150–1200 cm

- Ether ( ): Strong stretching vibrations at 1050–1100 cm (acetal).

## Mass Spectrometry (MS)

Ionization Mode: ESI+ or EI (70 eV)

- Molecular Ion ( ): 210.
- Base Peak: Often observed at 179 (Loss of ) or 75 (Acetal fragment).

Fragmentation Pathway (EI):

- 210: Parent Ion.
- 179: . Loss of one methoxy group is the primary fragmentation channel.
- 151: . Loss of the entire acetal side chain (less common) or sequential loss of CO.

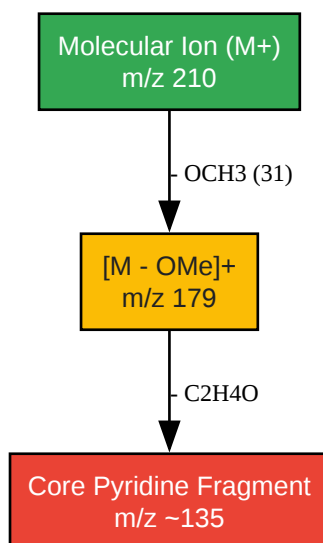

[Click to download full resolution via product page](#)

Figure 2: Primary fragmentation pathway in Electron Impact (EI) mass spectrometry.

## Experimental Validation Protocol

To verify the identity of a synthesized batch, follow this rapid validation workflow:

- Solubility Check: Dissolve 5 mg in 0.5 mL DMSO-
  - . The solution should be clear yellow. Turbidity suggests inorganic salts (NaCl/NaBr) from the neutralization step.
- H-NMR Acquisition: Run a standard 16-scan proton NMR.
  - Checkpoint: Verify the singlet at ~5.3 ppm (Acetal). If this is a doublet or absent, hydrolysis to the aldehyde has occurred.
  - Checkpoint: Verify the integration of OMe (6H) vs Aromatic H (1H each).
- IR Confirmation: Run a neat sample (ATR). Confirm the presence of the CN peak at 2222 cm

## References

- Litvinov, V. P., et al. (1999). "Synthesis and properties of 6-substituted 3-cyano-2(1H)-pyridinethiones." Russian Chemical Bulletin, 48(1), 168-174.
- El-Nagdi, M. H., et al. (1991). "Nitriles in Heterocyclic Synthesis: The Reaction of 2-Thiocarbamoyl Cinnamonitriles with Active Methylene Reagents." Journal of the Chemical Society, Perkin Transactions 1.
- PubChem Database. (2024).[1][2] "Compound Summary: **6-(Dimethoxymethyl)-2-mercaptonicotinitrile** (CAS 175277-23-3)."[3][4] National Center for Biotechnology Information.
- Vihasibio Sciences. (2023).[5] "Product List: Pyridine Derivatives and Intermediates."

### Need Custom Synthesis?

BenchChem offers custom synthesis for rare earth carbides and specific isotopic labeling.

Email: [info@benchchem.com](mailto:info@benchchem.com) or [Request Quote Online](#).

## Sources

- 1. 6-Mercaptonicotinic acid | C<sub>6</sub>H<sub>5</sub>NO<sub>2</sub>S | CID 819384 - PubChem [[pubchem.ncbi.nlm.nih.gov](https://pubchem.ncbi.nlm.nih.gov)]
- 2. Dihydroxybergamottin | C<sub>21</sub>H<sub>24</sub>O<sub>6</sub> | CID 12082365 - PubChem [[pubchem.ncbi.nlm.nih.gov](https://pubchem.ncbi.nlm.nih.gov)]
- 3. [bocsci.com](https://www.bocsci.com) [[bocsci.com](https://www.bocsci.com)]
- 4. [bocsci.com](https://www.bocsci.com) [[bocsci.com](https://www.bocsci.com)]
- 5. [scribd.com](https://www.scribd.com) [[scribd.com](https://www.scribd.com)]
- To cite this document: BenchChem. [Technical Guide: Spectroscopic Profiling of 6-(Dimethoxymethyl)-2-mercaptonicotinitrile]. BenchChem, [2026]. [Online PDF]. Available at: [<https://www.benchchem.com/product/b063809/docs#technical-guide-spectroscopic-profiling-of-6-dimethoxymethyl-2-mercaptonicotinitrile>]

### Disclaimer & Data Validity:

The information provided in this document is for Research Use Only (RUO) and is strictly not intended for diagnostic or therapeutic procedures. While BenchChem strives to provide accurate protocols, we make no warranties, express or implied, regarding the fitness of this product for every specific experimental setup.

**Technical Support:** The protocols provided are for reference purposes. Unsure if this reagent suits your experiment?

**Need Industrial/Bulk Grade?** [Request Custom Synthesis Quote](#)

## BenchChem

Our mission is to be the trusted global source of essential and advanced chemicals, empowering scientists and researchers to drive progress in science and industry.

### Contact

Address: 3281 E Guasti Rd  
Ontario, CA 91761, United States  
Phone: (601) 213-4426  
Email: [info@benchchem.com](mailto:info@benchchem.com)

[Contact our Ph.D. Support Team for a compatibility check](#)