

Comparative Guide: Mono- vs. Polysubstituted Azepanes in Drug Discovery

Author: BenchChem Technical Support Team. **Date:** May 2026

Compound of Interest

Compound Name: 2-(4-Methylphenyl)azepane

CAS No.: 168890-45-7

Cat. No.: B063979

[Get Quote](#)

Executive Summary

Content Type: Technical Comparison Guide Audience: Medicinal Chemists, Lead Optimization Scientists, and Process Chemists.

The seven-membered azepane ring represents a high-value but underutilized scaffold in modern drug discovery, often termed the "Azepane Gap." While piperidines (6-membered) and pyrrolidines (5-membered) dominate small-molecule libraries, azepanes offer unique three-dimensional spatial vectors.^{[1][2]} This guide compares Mono-substituted Azepanes (historically more accessible but conformationally labile) against Polysubstituted Azepanes (synthetically challenging but conformationally rigid and highly selective).

Key Finding: Recent photochemical breakthroughs (2024) have shifted the paradigm, making complex polysubstituted azepanes accessible in fewer steps than traditional mono-substituted analogs, unlocking new chemical space for kinase and glycosidase inhibition.

Part 1: Synthetic Accessibility & Efficiency

The primary barrier to azepane adoption has historically been synthetic difficulty. The choice between mono- and polysubstitution dictates the synthetic strategy.

Mono-substituted Azepanes: The Traditional Route

- Methodology: Ring-Closing Metathesis (RCM) or Beckmann Rearrangement.[3]
- Pros: Well-established protocols; predictable kinetics.
- Cons: High step count (linear precursor synthesis required); difficult to introduce multiple stereocenters; RCM often suffers from dimerization or poor yields for 7-membered rings due to entropic factors.

Polysubstituted Azepanes: The Modern "Dearomative" Route

- Methodology: Photochemical Dearomative Ring Expansion of Nitroarenes.[1][2][3]
- Mechanism: Blue-light mediated insertion of a nitrene equivalent into a benzene ring, followed by expansion.[1][2][3]
- Pros: Accesses complex, highly substituted scaffolds in 2 steps from abundant nitroarenes; inherent high character.
- Cons: Requires specialized photochemical equipment; substrate scope limited to nitroarene precursors.

Synthetic Workflow Comparison

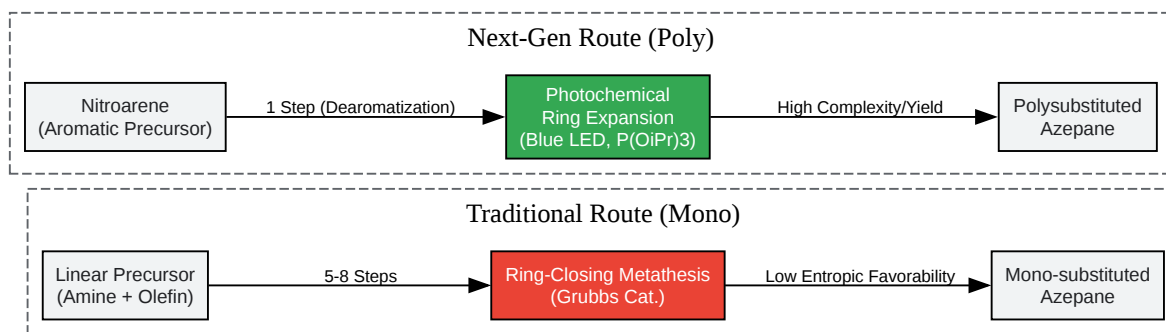

[Click to download full resolution via product page](#)

Figure 1: Comparative synthetic workflows. The modern photochemical route (green) offers a step-change in efficiency for accessing complex scaffolds compared to traditional RCM (red).

Part 2: Conformational Dynamics & Bioactivity

The biological performance of azepanes is governed by the flexibility of the 7-membered ring.

The Entropy Challenge

- Mono-substituted: The azepane ring exists in a flexible twist-chair conformation. Upon binding to a protein target, the molecule must "freeze" into a bioactive conformation. This results in a high entropic penalty (), potentially reducing overall affinity.
- Polysubstituted: Strategic placement of substituents (especially bulky groups or hydroxyls) restricts ring puckering. This "pre-organization" lowers the entropic cost of binding, often leading to higher affinity and selectivity.

Performance Data: Glycosidase Inhibition

Polysubstituted azepanes (specifically polyhydroxylated forms known as iminosugars) are potent inhibitors of glycosidases.^{[4][5]} The multiple hydroxyl groups mimic the transition state of sugar hydrolysis, while the ring nitrogen mimics the anomeric charge.

Table 1: Comparative Inhibition Profile (Glycosidase Targets)

| Compound Class | Substitution Pattern | Target Enzyme | IC50 / Ki | Mechanism of Action |
|----------------|------------------------|----------------|---------------------|---|
| Mono-Azepane | N-alkyl only | Non-specific | > 100 μM | Weak hydrophobic interaction; high flexibility. |
| Poly-Azepane | 3,4,5,6-Tetrahydroxy | -Galactosidase | 21 μM | Transition state mimicry; H-bond network matches active site. |
| Poly-Azepane | N-benzyl-3,4-dihydroxy | -Glucosidase | 15 μM | Hydrophobic anchor (benzyl) + Polar core (hydroxyls). |

“

Insight: The addition of hydroxyl groups (polysubstitution) transforms the scaffold from a generic hydrophobic linker into a highly specific "warhead" for enzymatic active sites.

Part 3: Experimental Protocols

Protocol A: Photochemical Synthesis of Polysubstituted Azepanes

Validates the "Next-Gen" route described in Part 1.

Objective: Synthesis of 2-aryl-substituted azepane via dearomative ring expansion. Reagents: Nitrobenzene derivative (1.0 equiv),

(excess), Amine nucleophile.

- Setup: Charge a borosilicate reaction vial with the nitroarene substrate (0.5 mmol) and triisopropyl phosphite (2.0 equiv).
- Irradiation: Place the vial in a photoreactor equipped with Blue LEDs (440–460 nm). Maintain temperature at 25°C using a fan.
- Reaction: Irradiate for 12–18 hours. The reaction proceeds via a singlet nitrene intermediate which inserts into the benzene ring to form a 3H-azepine.[3]
- Reduction (One-Pot): Add Pd/C (10 wt%) and connect to a hydrogen balloon (1 atm). Stir for 4 hours to reduce the unsaturated azepine to the saturated azepane.
- Purification: Filter through Celite and purify via silica gel flash chromatography (Eluent: DCM/MeOH).

Protocol B: Glycosidase Inhibition Assay

Validates the bioactivity claims in Part 2.

Objective: Determine IC₅₀ of polyhydroxylated azepane against

-galactosidase.

- Buffer Prep: Prepare 50 mM phosphate buffer (pH 6.8).
- Substrate: Dissolve
-nitrophenyl-
-D-galactopyranoside (pNPG) in buffer (2 mM).
- Incubation: In a 96-well plate, mix 10 µL of azepane inhibitor (serial dilutions: 1–1000 µM) with 80 µL of enzyme solution (0.2 U/mL). Incubate at 37°C for 10 mins.
- Initiation: Add 10 µL of pNPG substrate.
- Measurement: Monitor absorbance at 405 nm (release of

-nitrophenol) kinetically for 20 mins.

- Analysis: Plot % Inhibition vs. Log[Concentration] to derive IC50 using non-linear regression.

Part 4: Strategic Recommendations (SAR Logic)

When should you choose Mono- vs. Polysubstituted scaffolds?

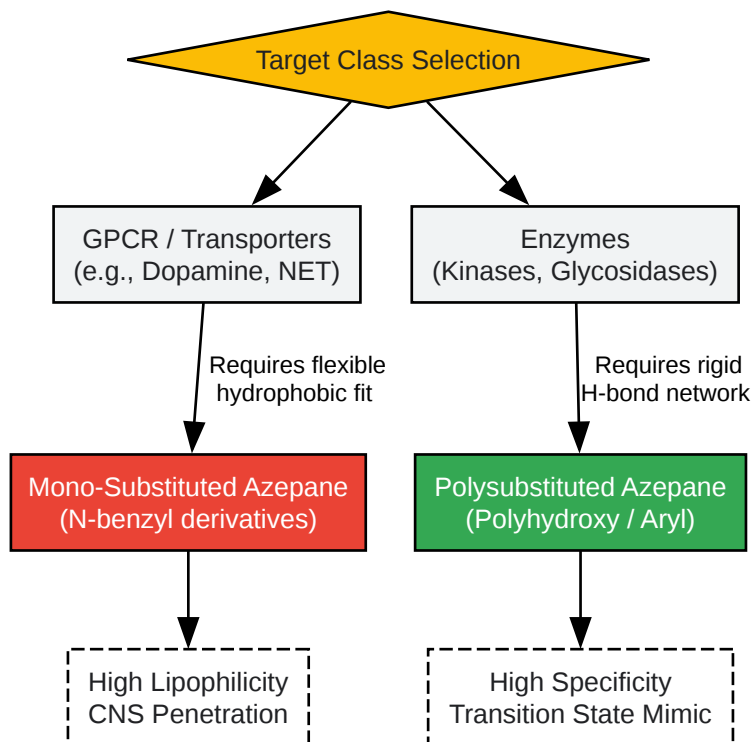

[Click to download full resolution via product page](#)

Figure 2: Decision matrix for scaffold selection based on biological target class.

Summary of Recommendations

- Use Mono-substituted Azepanes when targeting GPCRs or Transporters (e.g., Dopamine, Norepinephrine). The flexibility allows the ring to adapt to the deep hydrophobic pockets typical of these receptors.
- Use Polysubstituted Azepanes when targeting Enzymes (Kinases, Glycosidases). The rigidity provided by substituents is crucial for mimicking transition states and achieving high selectivity (low off-target effects).

- Adopt Photochemical Synthesis for library generation. The ability to generate polysubstituted cores from nitroarenes bypasses the "step-count penalty" traditionally associated with these complex rings.

References

- Mykura, R., et al. (2024).[6] Synthesis of polysubstituted azepanes by dearomative ring expansion of nitroarenes. Nature Chemistry. [Link](#)
- Behr, J. B., et al. (2014).[4] Synthesis of 2-carboxymethyl polyhydroxyazepanes and their evaluation as glycosidase inhibitors. Bioorganic Chemistry. [Link](#)
- Carrel, A., et al. (2025).[7] Exploring Simple Drug Scaffolds from the Generated Database Chemical Space Reveals a Chiral Bicyclic Azepane with Potent Neuropharmacology. Journal of Medicinal Chemistry. [Link](#)
- Dillen, J. (2022). Meta-Hybrid Density Functional Theory Prediction of the Reactivity, Stability, and IGM of Azepane. NIH/PubMed. [Link](#)
- BenchChem. (2025).[8] Comparative Analysis of Synthetic Routes to Azepane-2,4-dione. [Link](#)

Need Custom Synthesis?

BenchChem offers custom synthesis for rare earth carbides and specific isotopic labeling.

Email: info@benchchem.com or [Request Quote Online](#).

Sources

- 1. Synthesis of polysubstituted azepanes by dearomative ring expansion of nitroarenes - PubMed [pubmed.ncbi.nlm.nih.gov]
- 2. research.manchester.ac.uk [research.manchester.ac.uk]
- 3. researchgate.net [researchgate.net]
- 4. Synthesis of 2-carboxymethyl polyhydroxyazepanes and their evaluation as glycosidase inhibitors - PubMed [pubmed.ncbi.nlm.nih.gov]

- [5. researchgate.net \[researchgate.net\]](#)
- [6. researchgate.net \[researchgate.net\]](#)
- [7. Exploring Simple Drug Scaffolds from the Generated Database Chemical Space Reveals a Chiral Bicyclic Azepane with Potent Neuropharmacology \[gdb.unibe.ch\]](#)
- [8. pdf.benchchem.com \[pdf.benchchem.com\]](#)
- To cite this document: BenchChem. [Comparative Guide: Mono- vs. Polysubstituted Azepanes in Drug Discovery]. BenchChem, [2026]. [Online PDF]. Available at: [\[https://www.benchchem.com/product/b063979/docs#comparative-guide-mono-vs-polysubstituted-azepanes-in-drug-discovery\]](https://www.benchchem.com/product/b063979/docs#comparative-guide-mono-vs-polysubstituted-azepanes-in-drug-discovery)

Disclaimer & Data Validity:

The information provided in this document is for Research Use Only (RUO) and is strictly not intended for diagnostic or therapeutic procedures. While BenchChem strives to provide accurate protocols, we make no warranties, express or implied, regarding the fitness of this product for every specific experimental setup.

Technical Support: The protocols provided are for reference purposes. Unsure if this reagent suits your experiment?

Need Industrial/Bulk Grade? [Request Custom Synthesis Quote](#)

BenchChem

Our mission is to be the trusted global source of essential and advanced chemicals, empowering scientists and researchers to drive progress in science and industry.

Contact

Address: 3281 E Guasti Rd
Ontario, CA 91761, United States
Phone: (601) 213-4426
Email: info@benchchem.com

Contact our Ph.D. Support Team for a compatibility check