

# Application Note: Cyclization of 5-Iodocytosine with Chloroacetaldehyde

**Author:** BenchChem Technical Support Team. **Date:** April 2026

## Compound of Interest

Compound Name:	8-Iodo-6H-imidazo[1,2-c]pyrimidin-5-one
CAS No.:	1639927-31-3
Cat. No.:	B6299703

[Get Quote](#)

## Executive Summary

The reaction between cytosine derivatives and chloroacetaldehyde (CAA) yields 3,N4-etheno-bridged heterocycles. When applied to 5-iodocytosine, this cyclization produces 5-iodo-3,N4-ethenocytosine. While unsubstituted ethenocytosine is highly fluorescent, the presence of the 5-iodo substituent introduces a "heavy atom effect," which typically quenches fluorescence via intersystem crossing. Consequently, this specific derivative is most valuable not as a direct fluorophore, but as a bifunctional scaffold: the etheno group blocks the Watson-Crick face (simulating mutagenic damage), while the 5-iodo position remains available for Palladium-catalyzed cross-coupling (e.g., Sonogashira) to attach novel fluorophores or affinity tags.

## Chemical Mechanism

The formation of the etheno bridge is a two-step alkylation-dehydration process.

- **Nucleophilic Attack:** The exocyclic amine (N4) of 5-iodocytosine attacks the carbonyl carbon of chloroacetaldehyde.

- Cyclization: The ring nitrogen (N3) attacks the alkyl chloride carbon, displacing the chloride.
- Dehydration: Loss of water yields the aromatic etheno-bridged system.

## Reaction Pathway Diagram[1][2]

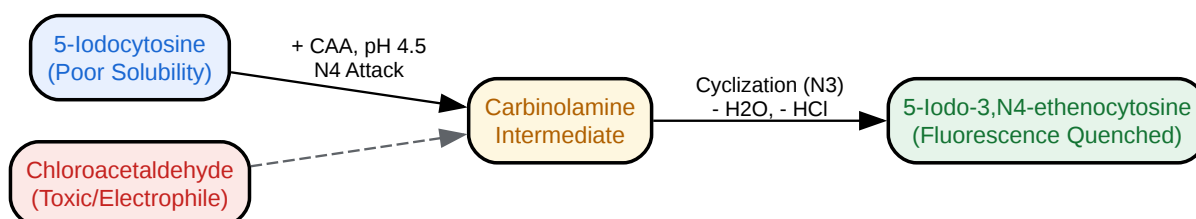

[Click to download full resolution via product page](#)

Caption: Mechanistic pathway from 5-iodocytosine to the etheno-bridged adduct via a carbinolamine intermediate.

## Experimental Protocol

### A. Reagents and Equipment[1][3][4]

- Substrate: 5-Iodocytosine (Solid, >98% purity).
- Reagent: Chloroacetaldehyde (CAA), ~50% wt. solution in water.
  - Warning: CAA is highly toxic and a known carcinogen. Handle strictly in a fume hood.
- Buffer: 1.0 M Sodium Acetate buffer (pH 4.5).
- Solvent: Dimethylformamide (DMF) (Required for solubility of the iodinated base).
- Equipment: Heating block/oil bath, HPLC (C18 column), UV-Vis spectrophotometer.

### B. Step-by-Step Procedure

#### Phase 1: Preparation

- CAA Activation: Commercial CAA solution often contains polymerized forms. If the reagent is old, distill it or treat with sodium bicarbonate to release the monomer, though fresh

commercial 50% solutions usually work directly.

- Solubilization: 5-Iodocytosine has poor aqueous solubility. Dissolve 1.0 mmol (approx. 237 mg) of 5-iodocytosine in 5 mL of warm DMF.
  - Note: If using the nucleoside (5-iodo-2'-deoxycytidine), it is water-soluble; omit DMF and dissolve directly in buffer.

## Phase 2: Reaction

- Buffering: Add 5 mL of 1.0 M Sodium Acetate buffer (pH 4.5) to the DMF solution. The final pH should be between 4.0 and 5.0.
- Addition: Add 10.0 mmol (excess) of Chloroacetaldehyde solution.
- Incubation: Seal the reaction vessel and heat to 50°C with stirring.
  - Duration: The reaction typically requires 24–48 hours. The electron-withdrawing iodine atom may slightly deactivate the ring compared to unsubstituted cytosine, requiring longer times.

## Phase 3: Monitoring & Workup

- Monitoring: Monitor by HPLC or TLC (Silica, 10% MeOH in DCM).
  - Indicator: Disappearance of the 5-iodocytosine peak and appearance of a new, slightly more hydrophobic peak.
  - UV Check: The product will exhibit a characteristic etheno-absorbance band around 270–300 nm.
- Quenching: Cool the mixture to room temperature. Neutralize with dilute NaOH to pH 7.0.
- Purification:
  - Method A (Precipitation): If the product precipitates upon cooling/neutralization, filter and wash with cold water.

- Method B (Preparative HPLC): For high purity, inject onto a C18 column. Elute with a gradient of Water/Acetonitrile (0% to 40% ACN). Collect the major peak.
- Drying: Lyophilize the collected fractions to obtain a white to off-white powder.

## Experimental Workflow Diagram

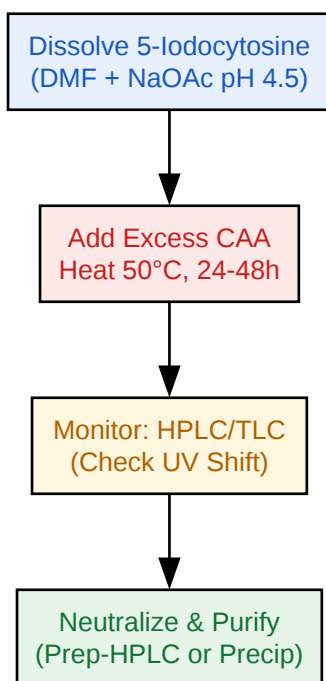

[Click to download full resolution via product page](#)

Caption: Operational workflow for the synthesis and purification of 5-iodo-3,N4-ethenocytosine.

## Analytical Validation

To ensure the integrity of the synthesized product, compare analytical data against the expected values in the table below.

Parameter	5-Iodocytosine (Starting Material)	5-Iodo-3,N4-ethenocytosine (Product)
UV Max ( )	~285 nm (pH 7)	~275 nm, shoulder ~300 nm
Fluorescence	Non-fluorescent	Weak/Quenched (due to Iodine)
Mass Spec (ESI+)	[M+H] <sup>+</sup> = 238.0	[M+H] <sup>+</sup> = 262.0 (+24 Da for C <sub>2</sub> H <sub>0</sub> )
Solubility	Poor in water	Moderate in water/MeOH

Critical Note on Fluorescence: While standard 3,N4-ethenocytosine is highly fluorescent, the 5-iodo derivative exhibits significantly reduced quantum yield. This is due to the "Heavy Atom Effect" of iodine, which facilitates intersystem crossing from the singlet excited state to the triplet state, quenching fluorescence. Do not use fluorescence intensity as the primary metric for yield; rely on UV absorbance (HPLC).

## Troubleshooting & Optimization

- **Incomplete Reaction:** If starting material persists after 48h, add a second aliquot of CAA and increase temperature to 60°C. Ensure pH remains < 5.0, as the reaction stalls at neutral/alkaline pH.
- **Precipitation:** If the reaction mixture becomes cloudy immediately, the substrate may have crashed out. Add more DMF or warm the solution.
- **Degradation:** Long exposure to high heat (>70°C) in acidic conditions can lead to deiodination. Maintain moderate temperatures (37-50°C).

## References

- Krzyzosiak, W. J., et al. (1983). "Comparative studies on reactions of adenosine and cytidine with chloroacetaldehyde." Polish Journal of Chemistry.

- Barrio, J. R., et al. (1972).[1] "Fluorescent adenosine and cytidine derivatives." Biochemical and Biophysical Research Communications.
- Leonard, N. J. (1984). "Etheno-substituted nucleotides and coenzymes: fluorescence and biological activity." CRC Critical Reviews in Biochemistry.
- Saparbaev, M., et al. (1998).[2] "3,N4-ethenocytosine, a highly mutagenic adduct, is a primary substrate for Escherichia coli double-stranded uracil-DNA glycosylase." [2] PNAS.[2] [3]
- Hudson, R. H. E., et al. (2004). "Chemistry for the synthesis of nucleobase-modified peptide nucleic acid." Pure and Applied Chemistry. (Discusses 5-iodocytosine coupling).[4][5]

#### Need Custom Synthesis?

BenchChem offers custom synthesis for rare earth carbides and specific isotopic labeling.

Email: [info@benchchem.com](mailto:info@benchchem.com) or [Request Quote Online](#).

## Sources

- 1. The reaction of adenine and cytosine residues in tRNA with chloroacetaldehyde - PMC [[pmc.ncbi.nlm.nih.gov](https://pubmed.ncbi.nlm.nih.gov/1122447/)]
- 2. DNAMod: 3,N4-ethenocytosine [[dnamod.hoffmanlab.org](http://dnamod.hoffmanlab.org/)]
- 3. 3,N4-ethenocytosine, a highly mutagenic adduct, is a primary substrate for Escherichia coli double-stranded uracil-DNA glycosylase and human mismatch-specific thymine-DNA glycosylase - PubMed [[pubmed.ncbi.nlm.nih.gov](https://pubmed.ncbi.nlm.nih.gov/1122447/)]
- 4. 5-Iodocytosine 1122-44-7 [[sigmaaldrich.com](https://www.sigmaaldrich.com/1122447)]
- 5. Nucleotides for Application in Cell Cycle & Proliferation - Jena Bioscience [[jenabioscience.com](https://www.jenabioscience.com/)]
- To cite this document: BenchChem. [Application Note: Cyclization of 5-Iodocytosine with Chloroacetaldehyde]. BenchChem, [2026]. [Online PDF]. Available at: [<https://www.benchchem.com/product/b6299703/docs#application-note-cyclization-of-5-iodocytosine-with-chloroacetaldehyde>]

#### Disclaimer & Data Validity:

The information provided in this document is for Research Use Only (RUO) and is strictly not intended for diagnostic or therapeutic procedures. While BenchChem strives to provide accurate protocols, we make no warranties, express or implied, regarding the fitness of this product for every specific experimental setup.

**Technical Support:** The protocols provided are for reference purposes. Unsure if this reagent suits your experiment?

**Need Industrial/Bulk Grade?** [Request Custom Synthesis Quote](#)

## BenchChem

Our mission is to be the trusted global source of essential and advanced chemicals, empowering scientists and researchers to drive progress in science and industry.

### Contact

Address: 3281 E Guasti Rd  
Ontario, CA 91761, United States  
Phone: (601) 213-4426  
Email: [info@benchchem.com](mailto:info@benchchem.com)

[Contact our Ph.D. Support Team for a compatibility check](#)