

# Application Note: GRGDS Peptide Surface Modification for Enhanced Cell Adhesion

**Author:** BenchChem Technical Support Team. **Date:** April 2026

## Compound of Interest

Compound Name:	<i>H-Gly-Arg-Gly-Asp-Ser-NH2</i> <i>Trifluoroacetate</i>
CAS No.:	143648-02-6
Cat. No.:	B6295725

[Get Quote](#)

## Abstract

The modification of synthetic biomaterials with bioactive peptides is a cornerstone of tissue engineering and regenerative medicine. This guide details the strategic application of GRGDS (Gly-Arg-Gly-Asp-Ser), a linear pentapeptide derived from fibronectin, to promote specific cell adhesion via integrin receptors. Unlike passive protein adsorption, covalent tethering of GRGDS provides a stable, tunable interface. This document outlines the mechanistic rationale, critical design parameters (spacer length, ligand density), and a validated EDC/NHS conjugation protocol for carboxylated surfaces.

## Introduction: The Mechanistic Basis

Synthetic biomaterials (e.g., PLGA, PEG hydrogels, Titanium) are often biologically inert ("blind" to cells). Cells require specific anchorage points to survive, proliferate, and differentiate—a phenomenon known as anchorage dependence.

The RGD (Arg-Gly-Asp) motif is the minimal recognition sequence found in Extracellular Matrix (ECM) proteins like fibronectin and vitronectin. It binds primarily to transmembrane integrin

receptors (specifically

and

).

## Why GRGDS?

While the tripeptide RGD is the binding core, the flanking residues dictate stability and conformation.

- GRGDS includes a glycine spacer (N-terminus) and a serine residue (C-terminus).[1]
- Cost-Benefit: It is significantly more stable and cost-effective than cyclic RGD (cRGD) peptides while retaining sufficient affinity ( ) for most mesenchymal cell types.
- Versatility: It promotes the formation of focal adhesions, linking the ECM to the actin cytoskeleton, triggering intracellular signaling pathways (FAK/Src) essential for cell survival.

## Diagram 1: Integrin-Ligand Interaction Mechanism

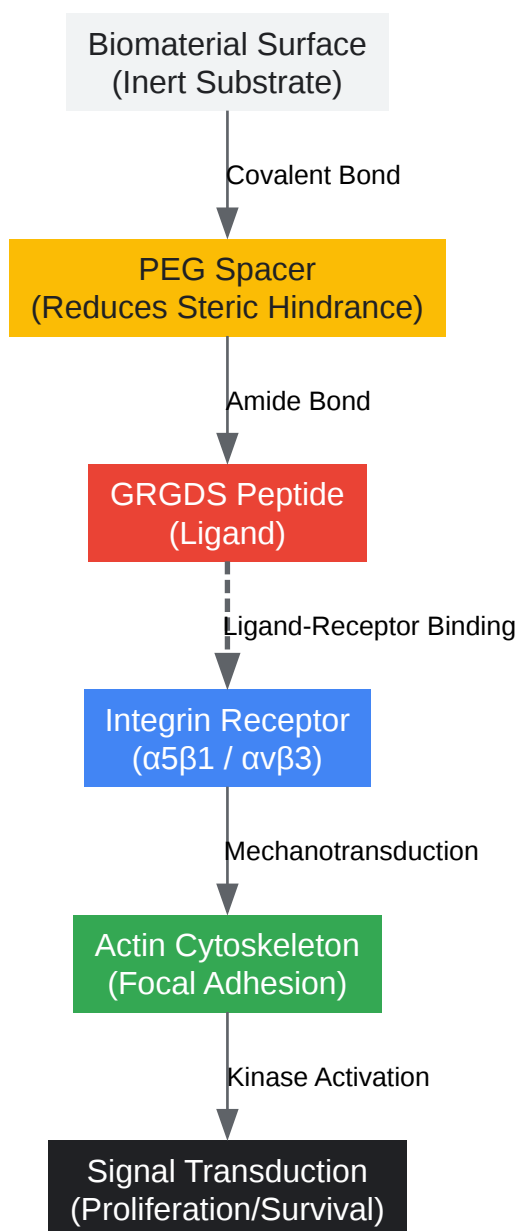

[Click to download full resolution via product page](#)

Caption: Schematic of the molecular bridge formed by GRGDS grafting.[2] The spacer is critical to project the peptide out of the surface hydration layer, making it accessible to the integrin headpiece.

## Strategic Design Parameters

Before pipetting, you must define the surface architecture. "More peptide" is not always better.

## Spacer Length (The "Reach")

Direct conjugation of GRGDS to a surface often fails because the peptide is buried in the material's hydration shell or sterically hindered by the polymer backbone.

- Recommendation: Use a hetero-bifunctional PEG spacer (e.g.,  
  
).
- Critical Threshold: A spacer length of ~3.5 nm (approx. PEG6 to PEG10) is often cited as optimal for maximizing integrin accessibility without inducing conformational entropy penalties [1, 2].

## Ligand Density (The "Spacing")

Integrin clustering is required for stable focal adhesion formation.

- Optimal Range:  
  
.
- Lower Limit:  
  
typically results in rounded cell morphology (no spreading).
- Upper Limit:  
  
can cause "integrin saturation" where receptors bind individual ligands but cannot cluster, paradoxically reducing adhesion strength [3].

Parameter	Optimal Target	Consequence of Deviation
Density		Low: Detachment. High: Reduced focal adhesion turnover.
Spacing		prevents integrin clustering.
Spacer	PEG (MW 200-600 Da)	None: Steric hindrance. Too Long: Peptide buries in surface.

## Protocol: Covalent Grafting via EDC/NHS

Model System: Carboxyl-functionalized surface (e.g., PLGA, PAA-hydrogel, or COOH-SAM on Gold). Chemistry: Carbodiimide crosslinking (Amine-Reactive).

### Reagents Required[2][3][4][5][6]

- GRGDS Peptide:
  - purity. (N-terminus must be free; C-terminus should be amidated if not part of the linkage).
- EDC (1-Ethyl-3-(3-dimethylaminopropyl)carbodiimide): Water-soluble zero-length crosslinker.
- NHS (N-Hydroxysuccinimide): Stabilizes the amine-reactive intermediate.
- Activation Buffer: 0.1 M MES, 0.5 M NaCl, pH 6.0 (Strictly non-amine buffer).
- Conjugation Buffer: PBS or Borate buffer, pH 7.4 - 8.0.
- Quenching Solution: 1 M Glycine or Ethanolamine.

### Diagram 2: Experimental Workflow



[Click to download full resolution via product page](#)

Caption: Step-by-step workflow for EDC/NHS mediated peptide grafting. Note the pH shift between activation (pH 6) and conjugation (pH 8).

## Step-by-Step Methodology

### Phase 1: Surface Activation

- Preparation: Wash the carboxylated biomaterial surfaces (e.g., films/scaffolds) 3x with MES Activation Buffer.
- Solution Prep: Immediately before use, dissolve EDC (2 mg/mL) and NHS (5 mg/mL) in MES buffer.
  - Expert Tip: EDC is hygroscopic and hydrolyzes rapidly. Use fresh aliquots.
- Incubation: Submerge samples in the EDC/NHS solution for 15–30 minutes at room temperature with gentle shaking.
  - Mechanism:[\[2\]](#)[\[3\]](#)[\[4\]](#)[\[5\]](#)[\[6\]](#)[\[7\]](#) This converts -COOH groups into semi-stable NHS-esters.

### Phase 2: Peptide Conjugation[\[8\]](#)

- Rinse: Quickly rinse the activated surface with MES buffer to remove unreacted EDC. Do not let the surface dry.
- Reaction: Immediately add the GRGDS peptide solution (dissolved in PBS, pH 8.0).
  - Concentration: Typically  
depending on desired density.
  - Time: Incubate for 2–4 hours at room temperature or overnight at  
.
  - pH Control: The coupling reaction requires the N-terminal amine of the peptide to be unprotonated (pH > pKa of N-terminus)

7.6).

### Phase 3: Quenching and Washing (Crucial)

- Quench: Add Quenching Solution (e.g., hydroxylamine or glycine) for 30 minutes to block remaining active NHS-esters.
- Desorption: Wash extensively to remove non-covalently adsorbed peptide.
  - 3x with PBS.
  - 1x with High Salt PBS (0.5 M NaCl) or mild surfactant (0.05% Tween-20) if material permits.
  - 3x with Sterile PBS.

## Characterization & Validation

### Physicochemical Characterization

Before adding cells, prove the chemistry worked.

- XPS (X-ray Photoelectron Spectroscopy):
  - Look for the appearance of a Nitrogen (N1s) peak on non-nitrogenous materials (like PLGA or Gold).
  - High-resolution C1s scan should show amide bond signals ( ).
- Contact Angle Goniometry:
  - GRGDS is hydrophilic. Successful grafting on hydrophobic polymers (e.g., PCL, PLGA) typically results in a decrease in water contact angle (e.g., from to ).

## Biological Validation (Cell Adhesion Assay)

- Cell Type: Use robust adhesive cells (e.g., HUVECs, NIH/3T3 Fibroblasts, or MSCs).
- Control Groups (Mandatory):
  - Bare Material: (Negative Control)
  - Scrambled Peptide: Graft GRDGS (swapped D and G). This proves adhesion is sequence-specific and not just due to surface charge.
  - Soluble RGD Competition: Add soluble GRGDS (1 mM) to the media. If adhesion is integrin-mediated, the soluble peptide will block receptors and inhibit attachment.

## Troubleshooting & Expert Tips

Issue	Probable Cause	Corrective Action
Low Cell Adhesion	Hydrolysis of NHS-ester	Minimize time between Activation and Conjugation (< 2 mins). Ensure EDC is fresh.
Non-Specific Adhesion	Inadequate Blocking	Use BSA (1%) or PEGylation to block the background surface.
No Difference vs Control	Peptide buried	Increase spacer length (use PEG-GRGDS).
Precipitation	Isoelectric Point (pI)	GRGDS is soluble, but hydrophobic spacers might precipitate. Dissolve in small amount of DMSO first if needed.

## References

- Hersel, U., et al. (2003).<sup>[5]</sup> RGD modified polymers: biomaterials for stimulated cell adhesion and beyond.<sup>[5][6][9][10][11][12]</sup> *Biomaterials*, 24(24), 4385-4415.

- Beer, J. H., et al. (1992). The effect of spacer length on the adhesion of endothelial cells to RGD-modified surfaces.[7][9][13] Journal of Biomedical Materials Research.
- Massia, S. P., & Hubbell, J. A. (1991). An RGD spacing of 440 nm is sufficient for integrin alpha V beta 3-mediated fibroblast spreading and 140 nm for focal contact and stress fiber formation.[7] Journal of Cell Biology, 114(5), 1089-1100.
- G-Biosciences. (n.d.). EDC/NHS Coupling Protocol.[2][14][15]
- Le Saux, G., et al. (2011). The Relative Importance of Topography and RGD Ligand Density for Endothelial Cell Adhesion. PLoS ONE.

### Need Custom Synthesis?

BenchChem offers custom synthesis for rare earth carbides and specific isotopic labeling.

Email: [info@benchchem.com](mailto:info@benchchem.com) or [Request Quote Online](#).

## Sources

- 1. [academic.oup.com](http://academic.oup.com) [[academic.oup.com](http://academic.oup.com)]
- 2. In Situ Monitoring of Linear RGD-Peptide Bioconjugation with Nanoscale Polymer Brushes - PMC [[pmc.ncbi.nlm.nih.gov](http://pmc.ncbi.nlm.nih.gov)]
- 3. Comparison between RGD-peptide-modified titanium and borosilicate surfaces - PubMed [[pubmed.ncbi.nlm.nih.gov](http://pubmed.ncbi.nlm.nih.gov)]
- 4. DSpace [[repository.upenn.edu](http://repository.upenn.edu)]
- 5. [researchgate.net](http://researchgate.net) [[researchgate.net](http://researchgate.net)]
- 6. [researchgate.net](http://researchgate.net) [[researchgate.net](http://researchgate.net)]
- 7. [journals.plos.org](http://journals.plos.org) [[journals.plos.org](http://journals.plos.org)]
- 8. [pubs.acs.org](http://pubs.acs.org) [[pubs.acs.org](http://pubs.acs.org)]
- 9. [mdpi.com](http://mdpi.com) [[mdpi.com](http://mdpi.com)]
- 10. Peptides for Surface Modification Applicate of Vascular Polymer - UCL Discovery [[discovery.ucl.ac.uk](http://discovery.ucl.ac.uk)]
- 11. [mdpi.com](http://mdpi.com) [[mdpi.com](http://mdpi.com)]

- [12. researchgate.net \[researchgate.net\]](#)
- [13. The effect of spacer arm length of an adhesion ligand coupled to an alginate gel on the control of fibroblast phenotype - PubMed \[pubmed.ncbi.nlm.nih.gov\]](#)
- [14. General Protocol for Coupling Biomolecules to Carboxylate Particles using EDC/Sulfo-NHS \[echobiosystems.com\]](#)
- [15. pubs.acs.org \[pubs.acs.org\]](#)
- To cite this document: BenchChem. [Application Note: GRGDS Peptide Surface Modification for Enhanced Cell Adhesion]. BenchChem, [2026]. [Online PDF]. Available at: [\[https://www.benchchem.com/product/b6295725/docs#application-note-grgds-peptide-surface-modification-for-enhanced-cell-adhesion\]](https://www.benchchem.com/product/b6295725/docs#application-note-grgds-peptide-surface-modification-for-enhanced-cell-adhesion)

---

### Disclaimer & Data Validity:

The information provided in this document is for Research Use Only (RUO) and is strictly not intended for diagnostic or therapeutic procedures. While BenchChem strives to provide accurate protocols, we make no warranties, express or implied, regarding the fitness of this product for every specific experimental setup.

**Technical Support:** The protocols provided are for reference purposes. Unsure if this reagent suits your experiment?

**Need Industrial/Bulk Grade?** [Request Custom Synthesis Quote](#)

## BenchChem

Our mission is to be the trusted global source of essential and advanced chemicals, empowering scientists and researchers to drive progress in science and industry.

### Contact

Address: 3281 E Guasti Rd  
Ontario, CA 91761, United States  
Phone: (601) 213-4426  
Email: [info@benchchem.com](mailto:info@benchchem.com)

Contact our Ph.D. Support Team for a compatibility check