

The Identity Matrix: 4-Butoxy-2,3-difluoroiodobenzene

Author: BenchChem Technical Support Team. **Date:** April 2026

Compound of Interest

Compound Name: 1-Butoxy-2,3-difluoro-4-iodobenzene
CAS No.: 1366126-91-1
Cat. No.: B6293267

[Get Quote](#)

A Technical Guide to Nomenclature, Synthesis, and Application Utility

Executive Summary

In the precision-driven fields of liquid crystal (LC) engineering and medicinal chemistry, 4-butoxy-2,3-difluoroiodobenzene (CAS 1366126-91-1) serves as a critical "scaffold node." It is not merely a reagent; it is a structural determinant used to introduce high dielectric anisotropy and lipophilicity into complex aromatic systems.

This guide moves beyond a simple list of synonyms. It deconstructs the compound's identity to aid in database mining, patent analysis, and procurement. Furthermore, it provides a self-validating protocol for its synthesis, ensuring that researchers can verify the material's integrity before integrating it into high-value workflows.

Part 1: Chemical Identity & Digital Aliases

For the research scientist, a name is a search query. Variations in nomenclature can lead to missed patents or supply chain dead ends. Below is the definitive identity matrix for this compound.

The Nomenclature Hierarchy

Naming Convention	Identifier / Name	Technical Context
IUPAC (Preferred)	1-Butoxy-2,3-difluoro-4-iodobenzene	The most rigorous structural descriptor. Used in high-impact journals and regulatory filings.
Systematic Inversion	Benzene, 1-butoxy-2,3-difluoro-4-iodo-	Common in CAS indexing and bulk chemical catalogs.
Positional Variant	4-Butoxy-2,3-difluoro-1-iodobenzene	Often used when the iodine is the reactive focal point (e.g., for cross-coupling).
CAS Registry Number	1366126-91-1	The unique digital fingerprint. Note: Do not confuse with the bromo-analog (247176-22-3).
SMILES	<chem>CCCCOC1=C(F)C(F)=C(I)C=C1</chem>	Machine-readable string for cheminformatics and docking simulations. ^[1]
InChI Key	Specific to isomer	Used for database deduplication.

Structural Logic Visualization

The following diagram illustrates the "why" behind the naming, highlighting the priority rules that dictate the numbering scheme.

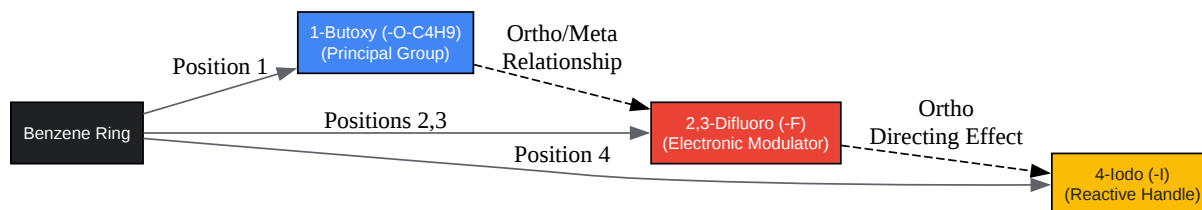

[Click to download full resolution via product page](#)

Figure 1: Structural decomposition of **1-butoxy-2,3-difluoro-4-iodobenzene**, illustrating the numbering priority based on the principal alkoxy group.

Part 2: Synthesis & Field-Proven Protocols

The Causality of Synthesis

Why does this specific isomer exist? The synthesis relies on the ortho-lithiation principle. The fluorine atoms at positions 2 and 3 exert a strong inductive effect, making the proton at position 4 (ortho to F-3) significantly more acidic than the proton at position 6 (ortho to the alkoxy group). This electronic bias allows for high regioselectivity without the need for protecting groups.

Precision Protocol: Directed Ortho-Lithiation (DoM)

Objective: Synthesize 4-butoxy-2,3-difluoriodobenzene with >98% regiochemical purity.

Reagents:

- Substrate: 1-Butoxy-2,3-difluorobenzene (CAS 136239-66-2).
- Lithiation Agent: n-Butyllithium (2.5 M in hexanes).^{[2][3]}
- Quench: Iodine () in THF.
- Solvent: Anhydrous THF (dried over Na/Benzophenone).

Step-by-Step Workflow:

- **Cryogenic Setup:** Flame-dry a 3-neck round bottom flask under Argon flow. Charge with 1-butoxy-2,3-difluorobenzene (1.0 eq) and anhydrous THF (0.5 M concentration). Cool to -78°C (dry ice/acetone). Causality: Low temperature prevents benzyne formation and isomerization.
- **Lithiation:** Add n-BuLi (1.1 eq) dropwise over 30 minutes. Maintain internal temperature below -70°C .
- **Maturation:** Stir at -78°C for 1 hour. Observation: The solution may turn slightly yellow, indicating the formation of the aryllithium species.
- **Electrophilic Quench:** Dissolve Iodine (1.2 eq) in minimal THF. Add this solution dropwise to the lithiated intermediate.^[4] The color will transition from dark to light as the iodine is consumed.
- **Workup:** Allow to warm to room temperature. Quench with saturated aqueous (sodium thiosulfate) to remove excess iodine (indicated by the disappearance of the purple/brown color). Extract with Ethyl Acetate.

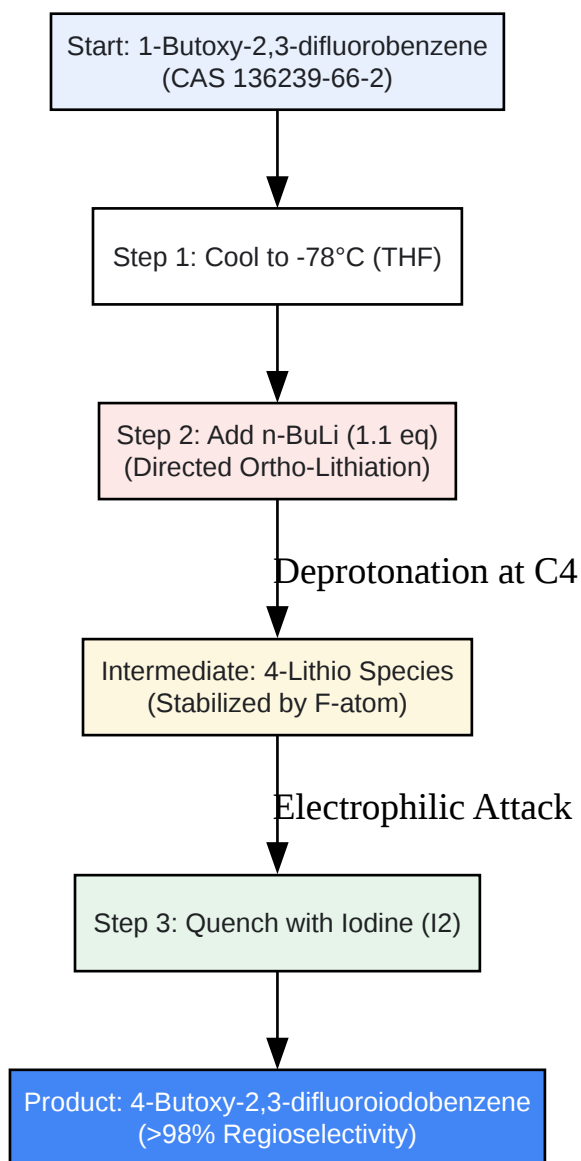

[Click to download full resolution via product page](#)

Figure 2: Reaction workflow for the regioselective synthesis of the target iodide via Directed Ortho-Metalation (DoM).

Part 3: Applications in Research & Development Liquid Crystal (LC) Engineering

This compound is a "mesogenic building block." The 2,3-difluoro motif induces a negative dielectric anisotropy (

), which is essential for Vertically Aligned (VA) LCD modes. The iodine handle allows for Suzuki-Miyaura coupling to extend the rigid core (e.g., attaching cyclohexyl or biphenyl groups), while the butoxy tail provides the necessary flexibility to lower the melting point and stabilize the nematic phase.

Medicinal Chemistry

In drug discovery, the 2,3-difluoro-4-alkoxy phenyl ring is a bioisostere for other electron-rich aromatics but with enhanced metabolic stability. The fluorine atoms block P450 oxidative sites, potentially increasing the half-life (

) of the final drug candidate.

Part 4: Physical Properties & Characterization Data

When validating the synthesized or purchased material, compare against these standard parameters.

Property	Value / Description	Method of Verification
Physical State	Low-melting solid or viscous liquid	Visual Inspection
Boiling Point	~250–260°C (Predicted)	Note: Bromo-analog boils at 234°C
Solubility	Soluble in DCM, THF, Ethyl Acetate	Insoluble in Water
¹ H NMR (CDCl ₃)	7.35 (m, 1H, H-5), 6.65 (m, 1H, H-6), 4.0 (t, 2H,)	Diagnostic triplet for and aromatic pattern.[1][3][5][6]
¹⁹ F NMR	Two distinct multiplets (~ -130 to -160 ppm)	Confirms 2,3-substitution pattern.

References

- Boroncore. (n.d.). 1366126-91-1 | **1-Butoxy-2,3-difluoro-4-iodobenzene**. Retrieved March 6, 2026, from [\[Link\]](#)
- Royal Society of Chemistry. (2013). Synthesis of 1,3-di-n-butoxy-4,6-diiodobenzene (Supplementary Information). Chemical Communications.[3] Retrieved March 6, 2026, from [\[Link\]](#)

Need Custom Synthesis?

BenchChem offers custom synthesis for rare earth carbides and specific isotopic labeling.

Email: info@benchchem.com or [Request Quote Online](#).

Sources

- 1. Synthesis and Application of 2,3-Difluorobromobenzene_Chemicalbook [\[chemicalbook.com\]](#)
- 2. n-Butyllithium (n-BuLi) [\[commonorganicchemistry.com\]](#)
- 3. rsc.org [\[rsc.org\]](#)
- 4. pdf.benchchem.com [\[pdf.benchchem.com\]](#)
- 5. Synthesis and crystallographic analysis of meso-2,3-difluoro-1,4-butanediol and meso-1,4-dibenzyloxy-2,3-difluorobutane - PMC [\[pmc.ncbi.nlm.nih.gov\]](#)
- 6. (Bis(trifluoroacetoxy)iodo)benzene - Wikipedia [\[en.wikipedia.org\]](#)
- To cite this document: BenchChem. [The Identity Matrix: 4-Butoxy-2,3-difluoroiodobenzene]. BenchChem, [2026]. [Online PDF]. Available at: [\[https://www.benchchem.com/product/b6293267/docs#the-identity-matrix-4-butoxy-2-3-difluoroiodobenzene\]](https://www.benchchem.com/product/b6293267/docs#the-identity-matrix-4-butoxy-2-3-difluoroiodobenzene)

Disclaimer & Data Validity:

The information provided in this document is for Research Use Only (RUO) and is strictly not intended for diagnostic or therapeutic procedures. While BenchChem strives to provide accurate protocols, we make no warranties, express or implied, regarding the fitness of this product for every specific experimental setup.

Technical Support: The protocols provided are for reference purposes. Unsure if this reagent suits your experiment?

Need Industrial/Bulk Grade? [Request Custom Synthesis Quote](#)

BenchChem

Our mission is to be the trusted global source of essential and advanced chemicals, empowering scientists and researchers to drive progress in science and industry.

Contact

Address: 3281 E Guasti Rd
Ontario, CA 91761, United States
Phone: (601) 213-4426
Email: info@benchchem.com

[Contact our Ph.D. Support Team for a compatibility check](#)