

# Technical Support Center: Bromination of Methoxy-Substituted Aromatic Compounds

**Author:** BenchChem Technical Support Team. **Date:** April 2026

## Compound of Interest

Compound Name: (2,5-Dibromo-3-methoxyphenyl)methanol

CAS No.: 2385491-94-9

Cat. No.: B6290601

[Get Quote](#)

Welcome to the technical support center for the bromination of methoxy-substituted aromatic compounds. This guide is designed for researchers, scientists, and drug development professionals to navigate the complexities and common side reactions encountered during this fundamental synthetic transformation. Methoxy groups are potent activators in electrophilic aromatic substitution (EAS), which, while facilitating the reaction, can also lead to a variety of undesired outcomes. This document provides in-depth, cause-and-effect explanations in a question-and-answer format to help you troubleshoot experiments and optimize your synthetic strategy.

## Frequently Asked Questions (FAQs): Troubleshooting & Optimization

### Issue 1: Over-bromination and Poor Product Selectivity

Q1: My reaction is producing significant amounts of di- and even tri-brominated products. How can I achieve selective mono-bromination?

A1: This is the most common challenge when working with highly activated methoxy-substituted aromatics. The initial mono-brominated product is often still activated enough to undergo further bromination.<sup>[1][2][3]</sup> To enhance selectivity for the mono-substituted product, a multi-faceted approach focusing on controlling reactivity is essential.

- **Control Stoichiometry:** Strictly use a 1:1 or even slightly less (e.g., 0.95 equivalents) molar ratio of the brominating agent to your aromatic substrate. The slow, dropwise addition of the reagent prevents localized areas of high concentration that favor polybromination.<sup>[1][2]</sup>
- **Lower Reaction Temperature:** Reducing the temperature (e.g., to 0 °C or below) decreases the overall reaction rate. This provides a larger energy difference between the activation barriers for the first and second bromination events, thereby improving selectivity.<sup>[2][4]</sup>
- **Choose a Milder Brominating Agent:** While molecular bromine (Br<sub>2</sub>) is effective, its high reactivity can be difficult to control. Consider using a milder and more selective reagent like N-Bromosuccinimide (NBS).<sup>[2][5]</sup> NBS provides a low, steady concentration of electrophilic bromine, which is often key to preventing over-bromination.<sup>[6][7]</sup> For electron-rich substrates, NBS in a suitable solvent like DMF can provide high levels of para-selectivity.<sup>[8]</sup>

Q2: I'm observing a mixture of ortho and para isomers. How can I improve the regioselectivity of the reaction?

A2: The methoxy group is a strong ortho, para-director due to its ability to stabilize the arenium ion intermediate through resonance.<sup>[3][5]</sup> Typically, the para-product is favored due to the steric hindrance imposed by the methoxy group, which impedes attack at the ortho positions.<sup>[5][9]</sup>  
<sup>[10]</sup>

- **Solvent Choice:** The polarity of the solvent can influence the ortho/para ratio. Polar solvents can stabilize the transition states differently. For instance, bromination with NBS in acetonitrile has been shown to be highly para-selective.<sup>[10]</sup>
- **Temperature:** Lowering the reaction temperature can sometimes increase the preference for the thermodynamically more stable para isomer.<sup>[10]</sup>
- **Bulky Reagents:** While less common for bromination, using a bulkier brominating agent or catalyst system could theoretically increase steric hindrance at the ortho position, further favoring para substitution.

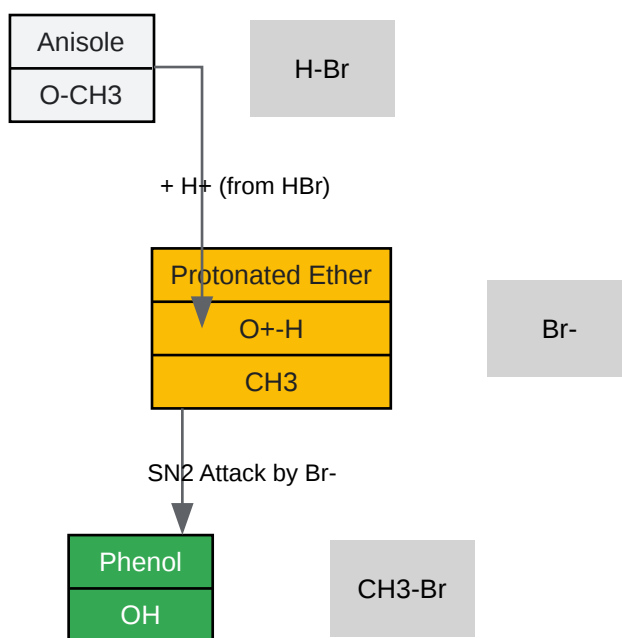

[Click to download full resolution via product page](#)

Caption: Mechanism of acid-catalyzed ether cleavage.

Q4: My substrate has an alkyl side-chain (e.g., 4-methylanisole), and I'm seeing bromination on the methyl group instead of the ring. Why is this happening?

A4: You are observing benzylic bromination, a radical-mediated reaction that competes with the desired electrophilic aromatic substitution. [3]The benzylic C-H bonds are weak and susceptible to radical abstraction. [11]

- Reaction Conditions Dictate the Pathway:
  - Radical (Benzylic) Bromination is favored by radical initiators (like AIBN or benzoyl peroxide), UV light, and non-polar solvents (like CCl<sub>4</sub>). [7][8]NBS is often used as the bromine source for this reaction, but the conditions determine the outcome. [7][11] \* Electrophilic (Aromatic) Bromination is an ionic process favored by polar solvents (like acetic acid or acetonitrile) and the absence of radical initiators. [6][12]
- To favor ring bromination: Conduct the reaction in the dark, use a polar solvent, and scrupulously avoid any radical initiators.

## Troubleshooting Guide: At-a-Glance

This table summarizes common experimental issues, their probable causes, and recommended solutions to get your reaction back on track.

Symptom Observed	Probable Cause(s)	Recommended Solution(s)
Multiple spots on TLC; polybrominated products by MS	1. Brominating agent is too reactive (e.g., Br <sub>2</sub> ). [2] 2. Molar ratio of brominating agent is > 1:1. [2] 3. Reaction temperature is too high. [1][2]	1. Switch to a milder reagent like NBS. [2][5] 2. Use a strict 1:1 stoichiometry; add brominating agent slowly. [1] 3. Run the reaction at a lower temperature (e.g., 0 °C). [4]
Low or No Conversion of Starting Material	1. Insufficient activation of brominating agent. 2. Reaction time or temperature is too low. [5] 3. Poor quality or degraded reagents. [4]	1. For less activated rings, a catalyst may be needed, but use with caution. [13][14] 2. Increase reaction time and monitor by TLC. Consider gentle heating if selectivity is not compromised. [4] 3. Use fresh, high-purity reagents and anhydrous solvents. [5]
Formation of Dark Tar or Colored Impurities	1. Ring oxidation by the brominating agent. [1][15] 2. Decomposition of starting material or product. 3. Strong acidic conditions causing side reactions.	1. Use milder conditions and avoid strong oxidizing agents. [1] 2. Lower the reaction temperature. 3. Ensure the workup neutralizes any acid byproducts (e.g., wash with NaHCO <sub>3</sub> solution). [4]
Loss of Methoxy Group (Phenol Formation)	Acid-catalyzed ether cleavage by HBr byproduct. [16][17]	1. Use NBS instead of Br <sub>2</sub> to minimize HBr formation. [8] 2. Avoid using Lewis acid catalysts. [2] 3. Add a non-nucleophilic base (proton sponge) to the reaction.
Bromination on Alkyl Side-Chain	Radical reaction conditions (light, radical initiator, non-polar solvent). [7][8][11]	1. Conduct the reaction in the dark. 2. Use a polar solvent (e.g., acetic acid, acetonitrile). [12] 3. Ensure no radical initiators are present.

## Validated Experimental Protocol: Selective para-Bromination of Anisole

This protocol provides a reliable method for the selective mono-bromination of anisole, a representative methoxy-substituted aromatic compound, with a high preference for the para-isomer.

### Reagents & Equipment:

- Anisole (1.0 equiv)
- N-Bromosuccinimide (NBS) (1.0 equiv, recrystallized)
- Acetonitrile (anhydrous)
- Round-bottom flask with stir bar
- Dropping funnel (optional, for larger scale)
- Ice bath
- TLC setup
- Separatory funnel
- Saturated sodium thiosulfate solution
- Saturated sodium bicarbonate solution
- Brine
- Anhydrous sodium sulfate or magnesium sulfate
- Rotary evaporator

### Procedure:

- **Reaction Setup:** In a clean, dry round-bottom flask equipped with a magnetic stir bar, dissolve anisole (1.0 equiv) in anhydrous acetonitrile (approx. 0.2 M concentration).
- **Cooling:** Place the flask in an ice bath and stir the solution for 10-15 minutes until the internal temperature reaches 0-5 °C.
- **Reagent Addition:** Add recrystallized NBS (1.0 equiv) to the stirred solution in small portions over 15-20 minutes. Maintain the temperature below 10 °C throughout the addition. **Self-Validation Point:** Portion-wise addition prevents an exotherm and maintains a low concentration of the brominating species, enhancing selectivity.
- **Reaction Monitoring:** Allow the reaction mixture to stir at 0-5 °C. Monitor the progress by TLC (e.g., using 9:1 Hexanes:Ethyl Acetate) every 30 minutes. The reaction is typically complete when the starting material spot is no longer visible (usually 1-3 hours).
- **Quenching:** Once the reaction is complete, pour the mixture into a beaker containing cold water. Add a saturated solution of sodium thiosulfate dropwise to quench any unreacted bromine/NBS (the faint yellow color should disappear).
- **Workup:** Transfer the mixture to a separatory funnel and extract the product with dichloromethane or ethyl acetate (3 x 20 mL).
- **Washing:** Combine the organic layers and wash sequentially with saturated sodium bicarbonate solution (to neutralize any trace acid), water, and finally brine. **Self-Validation Point:** The bicarbonate wash is crucial to remove acidic impurities that could promote decomposition or ether cleavage.
- **Drying and Concentration:** Dry the organic layer over anhydrous sodium sulfate, filter, and remove the solvent under reduced pressure using a rotary evaporator.
- **Purification:** The crude product, primarily a mixture of p-bromoanisole and a small amount of o-bromoanisole, can be purified by column chromatography on silica gel to isolate the desired para-isomer.

Caption: Experimental workflow for selective anisole bromination.

## References

- Chemia. (2022, April 8). Active/inactive aromatic ring bromination: Bromination reactions that use NBS (2). [\[Link\]](#)
- Filo. (2025, June 13). Discuss the role of lewis acid in the preparation of aryl bromide and chloride in the dark. [\[Link\]](#)
- Brainly.in. (2018, September 29). Discuss the role of lewis acid in the preparation of aryl bromide and chloride in the dark. [\[Link\]](#)
- JoVE. (2025, May 22). Electrophilic Aromatic Substitution: Chlorination and Bromination of Benzene. [\[Link\]](#)
- Making Molecules. (2025, June 19). Electrophilic Aromatic Substitution. [\[Link\]](#)
- Chemistry LibreTexts. (2023, August 7). 11.10: Benzylic Bromination of Aromatic Compounds. [\[Link\]](#)
- Master Organic Chemistry. (2011, June 10). Reagent Friday: NBS (N-Bromo Succinimide). [\[Link\]](#)
- OC-Praktikum. (2006, March). 1005 Bromination of 1,2-dimethoxybenzene to 4,5-dibromo-1,2. [\[Link\]](#)
- Wikipedia. (n.d.). N-Bromosuccinimide. [\[Link\]](#)
- PMC. (n.d.). Bromination from the Macroscopic Level to the Tracer Radiochemical Level: <sup>76</sup>Br Radiolabeling of Aromatic Compounds via Electrophilic Substitution. [\[Link\]](#)
- YouTube. (2021, February 11). electrophilic aromatic bromination with N-bromosuccinimide. [\[Link\]](#)
- Google Patents. (n.d.).
- MSU Chemistry. (n.d.). Substitution Reactions of Benzene and Other Aromatic Compounds. [\[Link\]](#)
- Unknown Source.

- Organic Chemistry Portal. (n.d.). Bromoarene synthesis by bromination or substitution. [[Link](#)]
- Jack Westin. (n.d.). Cleavage of Ethers. [[Link](#)]
- ACS Publications. (2015, May 26). Efficient and Practical Oxidative Bromination and Iodination of Arenes and Heteroarenes with DMSO and Hydrogen Halide: A Mild Protocol for Late-Stage Functionalization. [[Link](#)]
- Google Patents. (n.d.).
- Chemistry Stack Exchange. (2022, December 1). Are there any specific requirements for ipso substitution in aromatic compounds?. [[Link](#)]
- Longdom Publishing. (2022, November 16). Synthesis and Cleavage of Ethers. [[Link](#)]
- SlideShare. (2020, February 15). Aromatic Electrophilic substitution. [[Link](#)]
- ResearchGate. (n.d.). A New Regioselective Bromination of Activated Aromatic Rings. [[Link](#)]
- Wiley Online Library. (n.d.). Selective Electrochemical Dibromination of Terpenes and Naturally Derived Olefins. [[Link](#)]
- Digital Commons @ University of New Haven. (n.d.). Regiospecific P-Bromination of Activated Aromatic Systems – Greener Ap. [[Link](#)]
- LabXchange. (2025, January 2). Electrophilic Aromatic Substitution. [[Link](#)]
- Pearson+. (n.d.). The bromination of anisole occurs without the presence of a Lewis.... [[Link](#)]
- PMC. (n.d.). Regioselective Electrophilic Aromatic Bromination: Theoretical Analysis and Experimental Verification. [[Link](#)]
- Chemistry LibreTexts. (2022, September 24). 16.1: Electrophilic Aromatic Substitution Reactions - Bromination. [[Link](#)]
- Master Organic Chemistry. (2014, November 19). Cleavage Of Ethers With Acid. [[Link](#)]

- ACS Publications. (2024, September 25). Electrochemical Bromination of Arenes in a 200% Cell. [[Link](#)]
- Digital CSIC. (n.d.). Stepwise Mechanism for the Bromination of Arenes by a Hypervalent Iodine Reagent. [[Link](#)]
- Chemistry LibreTexts. (2024, March 19). 18.3: Reactions of Ethers - Acidic Cleavage. [[Link](#)]
- Chemistry Steps. (2020, July 20). Reactions of Ethers-Ether Cleavage. [[Link](#)]
- Reddit. (2020, August 7). Sonogashira troubleshooting help needed. [[Link](#)]
- ACS GCI Pharmaceutical Roundtable. (2026, February 25). Bromination. [[Link](#)]
- Google Patents. (n.d.).
- Unknown Source. Bromination Method for Anilines and Anisoles Using NH<sub>4</sub>Br/H<sub>2</sub>O<sub>2</sub> in CH<sub>3</sub>COOH. (Link not available)
- PMC. (n.d.). Electrochemical Bromination of Arenes in a 200% Cell. [[Link](#)]
- Oriental Journal of Chemistry. (n.d.). A Regioselective and Stereoselective Methoxy Bromination of Olefins using Diacetoxyiodobenzene and Phenyltrimethyl Ammoniumtribromide. [[Link](#)]
- ResearchGate. (2025, August 6). Superelectrophilic bromination of deactivated aromatic rings with tribromoisocyanuric acid—an experimental and DFT study. [[Link](#)]

### Need Custom Synthesis?

BenchChem offers custom synthesis for rare earth carbides and specific isotopic labeling.

Email: [info@benchchem.com](mailto:info@benchchem.com) or [Request Quote Online](#).

## Sources

- [1. pdf.benchchem.com \[pdf.benchchem.com\]](#)
- [2. pdf.benchchem.com \[pdf.benchchem.com\]](#)

- [3. crab.rutgers.edu](http://3.crab.rutgers.edu) [[crab.rutgers.edu](http://crab.rutgers.edu)]
- [4. pdf.benchchem.com](http://4.pdf.benchchem.com) [[pdf.benchchem.com](http://pdf.benchchem.com)]
- [5. pdf.benchchem.com](http://5.pdf.benchchem.com) [[pdf.benchchem.com](http://pdf.benchchem.com)]
- [6. Bromination reactions that use NBS\(active/inactive aromatic ring brominationActive/inactive aromatic ring bromination: Bromination reactions that use NBS\(2\):N-bromo compounds\(4\):Discussion series on bromination/iodination reactions 4 – Chemia](#) [[chemia.manac-inc.co.jp](http://chemia.manac-inc.co.jp)]
- [7. masterorganicchemistry.com](http://7.masterorganicchemistry.com) [[masterorganicchemistry.com](http://masterorganicchemistry.com)]
- [8. N-Bromosuccinimide - Wikipedia](http://8.N-Bromosuccinimide - Wikipedia) [[en.wikipedia.org](http://en.wikipedia.org)]
- [9. Aromatic Reactivity](http://9.Aromatic Reactivity) [[www2.chemistry.msu.edu](http://www2.chemistry.msu.edu)]
- [10. Regioselective Electrophilic Aromatic Bromination: Theoretical Analysis and Experimental Verification - PMC](http://10.Regioselective Electrophilic Aromatic Bromination: Theoretical Analysis and Experimental Verification - PMC) [[pmc.ncbi.nlm.nih.gov](http://pmc.ncbi.nlm.nih.gov)]
- [11. chem.libretexts.org](http://11.chem.libretexts.org) [[chem.libretexts.org](http://chem.libretexts.org)]
- [12. Bromination Method for Anilines and Anisoles Using NH<sub>4</sub>Br/H<sub>2</sub>O<sub>2</sub> in CH<sub>3</sub>COOH - \[www.rhodium.ws\] \[chemistry.mdma.ch](http://12.Bromination Method for Anilines and Anisoles Using NH4Br/H2O2 in CH3COOH - [www.rhodium.ws] [chemistry.mdma.ch)]
- [13. Discuss the role of lewis acid in the preparation of aryl bromide and chl.. \[askfilo.com\]](http://13.Discuss the role of lewis acid in the preparation of aryl bromide and chl.. [askfilo.com)
- [14. brainly.in](http://14.brainly.in) [[brainly.in](http://brainly.in)]
- [15. Bromination - Wordpress](http://15.Bromination - Wordpress [reagents.acsgcipr.org) [[reagents.acsgcipr.org](http://reagents.acsgcipr.org)]
- [16. jackwestin.com](http://16.jackwestin.com) [[jackwestin.com](http://jackwestin.com)]
- [17. masterorganicchemistry.com](http://17.masterorganicchemistry.com) [[masterorganicchemistry.com](http://masterorganicchemistry.com)]
- To cite this document: BenchChem. [Technical Support Center: Bromination of Methoxy-Substituted Aromatic Compounds]. BenchChem, [2026]. [Online PDF]. Available at: [<https://www.benchchem.com/product/b6290601/docs#technical-support-center-bromination-of-methoxy-substituted-aromatic-compounds>]

---

### Disclaimer & Data Validity:

The information provided in this document is for Research Use Only (RUO) and is strictly not intended for diagnostic or therapeutic procedures. While BenchChem strives to provide accurate protocols, we make no warranties, express or implied, regarding the fitness of this product for every specific experimental setup.

**Technical Support:** The protocols provided are for reference purposes. Unsure if this reagent suits your experiment?

**Need Industrial/Bulk Grade?** [Request Custom Synthesis Quote](#)

## BenchChem

Our mission is to be the trusted global source of essential and advanced chemicals, empowering scientists and researchers to drive progress in science and industry.

### Contact

Address: 3281 E Guasti Rd  
Ontario, CA 91761, United States  
Phone: (601) 213-4426  
Email: [info@benchchem.com](mailto:info@benchchem.com)

[Contact our Ph.D. Support Team for a compatibility check](#)