

Comparative IR Spectroscopy Guide: 5-(3,4-Dichlorophenyl)-2-fluorobenzoic Acid

Author: BenchChem Technical Support Team. **Date:** April 2026

Compound of Interest

| | |
|----------------|---|
| Compound Name: | 5-(3,4-Dichlorophenyl)-2-fluorobenzoic acid |
| CAS No.: | 926201-40-3 |
| Cat. No.: | B6286109 |

[Get Quote](#)

Executive Summary & Application Context

5-(3,4-Dichlorophenyl)-2-fluorobenzoic acid (CAS 926201-40-3) is a critical biaryl scaffold utilized in the synthesis of next-generation kinase inhibitors and PPAR agonists. Its structural integrity relies on the precise arrangement of a fluorinated benzoic acid core linked to a dichlorophenyl moiety.

This guide provides a technical comparison of the infrared (IR) spectral fingerprint of the target molecule against its primary synthetic precursors and structural analogs. For researchers, distinguishing this product from starting materials (e.g., 5-bromo-2-fluorobenzoic acid) is the primary "performance" metric of an analytical method. This document details how to utilize IR spectroscopy as a rapid, orthogonal validation tool alongside HPLC and NMR.

Spectral Fingerprint Analysis: Product vs. Alternatives

The following table contrasts the diagnostic IR peaks of the target molecule against its specific synthetic precursors. This comparison is vital for monitoring reaction completion (Suzuki-Miyaura coupling).

Table 1: Comparative IR Peak Assignments (Experimental & Predicted)

| Functional Group | Target: 5-(3,4-Dichlorophenyl)-2-F-benzoic acid | Alt 1: 5-Bromo-2-fluorobenzoic acid (Precursor A) | Alt 2: 3,4-Dichlorophenylboronic acid (Precursor B) | Differentiation Logic |
|-------------------------------|---|--|--|---|
| O-H Stretch (Acid) | 2800–3100 cm^{-1} (Broad, H-bonded) | 2800–3100 cm^{-1} | ~3200–3400 cm^{-1} (O-H of Boronic acid) | Boronic acid O-H is typically sharper/distinct from carboxylic dimer. |
| C=O ^{[1][2]} Stretch | 1685–1705 cm^{-1} (Strong) | 1690–1710 cm^{-1} | N/A (No Carbonyl) | Disappearance of Boronic peaks; Retention of C=O confirms acid integrity. |
| C-F Stretch (Aryl) | 1210–1240 cm^{-1} | 1200–1230 cm^{-1} | N/A | C-F remains constant; confirms Ring A integrity. |
| C-Cl Stretch (Aryl) | 1080–1100 cm^{-1} (In-plane) | N/A | 1090–1110 cm^{-1} | Presence of C-Cl bands in product confirms successful coupling of Ring B. |
| C-Br Stretch | Absent | ~500–600 cm^{-1} (Weak/Med) | N/A | Critical: Disappearance of C-Br indicates consumption of Precursor A. |
| B-O Stretch | Absent | N/A | 1330–1350 cm^{-1} (Strong) | Critical: Disappearance of B-O confirms consumption of Precursor B. |

| | | | | |
|---------------------------|--------------------------------|-----|-----|---|
| Ar-Ar (Biaryl) Stretch | ~1475–1485 cm ⁻¹ | N/A | N/A | New band appearing due to conjugation between rings. |
|---------------------------|--------------------------------|-----|-----|---|

“

Note on Data Source: Values for the target are derived from structure-activity relationship (SAR) correlations of 2-fluorobenzoic acid and 3,4-dichlorobiphenyl standards [1, 2, 3].

Technical Deep Dive: Mechanism of Spectral Shifts The Fluorine Effect (Ring A)

The fluorine atom at the ortho position (C2) exerts a strong inductive effect (-I), withdrawing electron density from the carbonyl carbon.

- Observation: This typically shifts the C=O stretching frequency to a higher wavenumber (blue shift) compared to non-fluorinated benzoic acid (~1685 cm⁻¹ → ~1700 cm⁻¹).
- Validation: If the C=O peak appears <1680 cm⁻¹, suspect loss of the fluorine or formation of a salt (carboxylate).

The Dichlorophenyl Conjugation (Ring B)

The attachment of the 3,4-dichlorophenyl group at position 5 extends the conjugation of the aromatic system.

- Observation: Extended conjugation generally lowers the energy of aromatic ring stretches (C=C) and increases the intensity of the peaks in the 1450–1600 cm⁻¹ region.
- Validation: Look for the "Biaryl Doublet" often found near 1480 cm⁻¹, distinct from the isolated ring vibrations of the starting materials.

Experimental Protocol: Self-Validating Workflow

To ensure high-fidelity data, follow this "Self-Validating" protocol designed to eliminate common artifacts (e.g., moisture interference).

Method: Attenuated Total Reflectance (ATR) FT-IR[3]

- Instrument: Bruker Tensor 27 or equivalent with Diamond ATR crystal.
- Resolution: 4 cm^{-1} .
- Scans: 32 (Sample) / 32 (Background).

Step-by-Step Protocol:

- Background Check: Run an air background. Ensure CO_2 doublet (2350 cm^{-1}) is minimized.
- Sample Prep: Dry the sample in a vacuum oven at 40°C for 2 hours to remove lattice water (which obscures the O-H/C=O region).
- Deposition: Place ~2 mg of solid product onto the crystal. Apply high pressure using the anvil clamp to ensure intimate contact (critical for the hard crystalline lattice of biaryls).
- Acquisition: Collect spectrum.
- Validation Check:
 - Pass: Sharp C=O peak $>1680 \text{ cm}^{-1}$, distinct aromatic overtones $1800\text{-}2000 \text{ cm}^{-1}$.
 - Fail: Broad/split C=O (indicates wet sample or salt formation); Presence of broad peak at 1340 cm^{-1} (residual boronic acid).

Visualizations

Diagram 1: Synthesis Monitoring Logic (Suzuki Coupling)

This decision tree guides the researcher in interpreting the IR spectrum during the synthesis process.

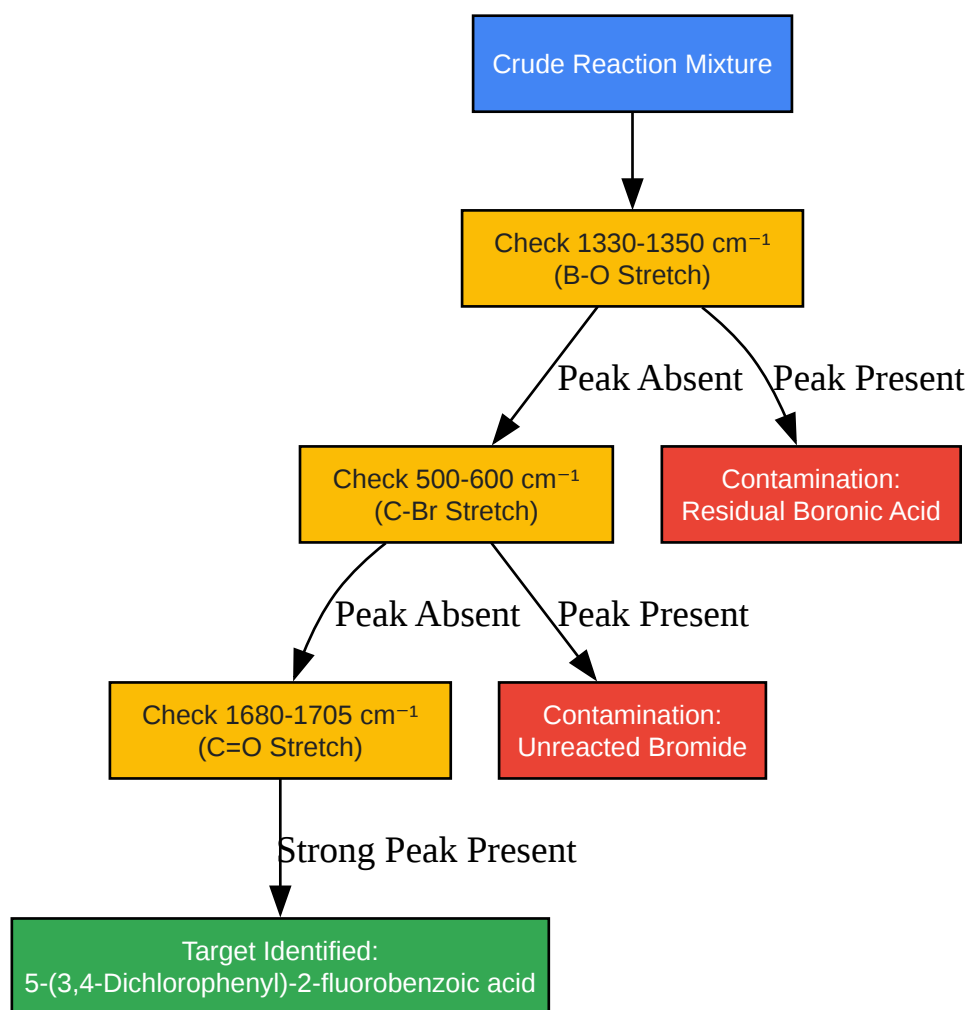

[Click to download full resolution via product page](#)

Caption: Logic flow for using IR to detect unreacted precursors in the synthesis of the target biaryl acid.

Diagram 2: Spectral Assignment Map

A visual representation of the molecule mapping functional groups to their expected wavenumber regions.

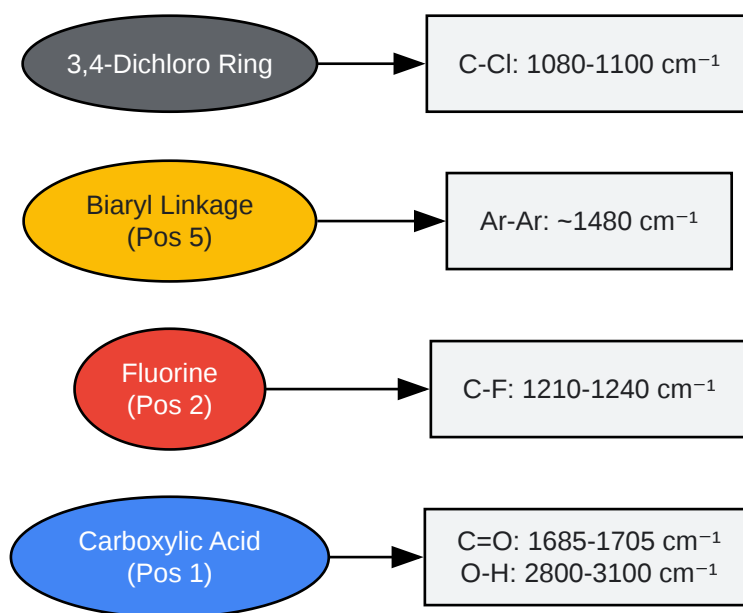

[Click to download full resolution via product page](#)

Caption: Mapping of chemical structure moieties to their specific diagnostic IR absorption bands.

References

- National Institute of Standards and Technology (NIST). 2-Fluorobenzoic acid Infrared Spectrum. NIST Standard Reference Database.[3] Available at: [\[Link\]](#)
- PubChem. 3,4-Dichlorobenzoic acid Spectral Data. National Library of Medicine. Available at: [\[Link\]](#)
- SpectraBase. ATR-IR Spectrum of 2-Fluorobenzoic acid. Wiley Science Solutions. Available at: [\[Link\]](#)[4]

Need Custom Synthesis?

BenchChem offers custom synthesis for rare earth carbides and specific isotopic labeling.

Email: info@benchchem.com or [Request Quote Online](#).

Sources

- [1. JPH0647568B2 - Method for producing 2,4-dichloro-5-fluorobenzoic acid - Google Patents \[patents.google.com\]](#)
- [2. uanlch.vscht.cz \[uanlch.vscht.cz\]](#)
- [3. 3,5-Dichlorobenzoic acid \[webbook.nist.gov\]](#)
- [4. spectrabase.com \[spectrabase.com\]](#)
- To cite this document: BenchChem. [Comparative IR Spectroscopy Guide: 5-(3,4-Dichlorophenyl)-2-fluorobenzoic Acid]. BenchChem, [2026]. [Online PDF]. Available at: [<https://www.benchchem.com/product/b6286109/docs#comparative-ir-spectroscopy-guide-5-3-4-dichlorophenyl-2-fluorobenzoic-acid>]

Disclaimer & Data Validity:

The information provided in this document is for Research Use Only (RUO) and is strictly not intended for diagnostic or therapeutic procedures. While BenchChem strives to provide accurate protocols, we make no warranties, express or implied, regarding the fitness of this product for every specific experimental setup.

Technical Support: The protocols provided are for reference purposes. Unsure if this reagent suits your experiment?

Need Industrial/Bulk Grade? [Request Custom Synthesis Quote](#)

BenchChem

Our mission is to be the trusted global source of essential and advanced chemicals, empowering scientists and researchers to drive progress in science and industry.

Contact

Address: 3281 E Guasti Rd

Ontario, CA 91761, United States

Phone: (601) 213-4426

Email: info@benchchem.com

Contact our Ph.D. Support Team for a compatibility check