

Technical Guide: The cis and trans Isomers of 2-Methoxycyclohexan-1-ol[1]

Author: BenchChem Technical Support Team. **Date:** May 2026

Compound of Interest

Compound Name:	2-Methoxycyclohexan-1-ol
CAS No.:	7429-41-6
Cat. No.:	B6278834

[Get Quote](#)

Abstract

The stereoisomers of **2-methoxycyclohexan-1-ol** represent a classic yet critical case study in conformational analysis and asymmetric synthesis. As vicinal functionalized cycloalkanes, their behavior is governed by a delicate interplay between steric repulsion, gauche interactions, and intramolecular hydrogen bonding (IMHB). This guide provides a definitive technical analysis of the cis and trans isomers, detailing their thermodynamic stability, synthetic pathways, and spectroscopic differentiation.

Part 1: Stereochemical Fundamentals & Conformational Analysis

The core distinction between the isomers lies in the relative orientation of the hydroxyl (-OH) and methoxy (-OMe) groups.

The Trans Isomer (Thermodynamic Product)

In the trans-1,2-disubstituted cyclohexane system, the substituents can adopt either a diequatorial (eq, eq) or diaxial (ax, ax) conformation.

- Diequatorial (eq, eq): This is the dominant conformer. The dihedral angle is approximately 60° , which allows for the formation of a stabilizing intramolecular hydrogen bond (IMHB) between the hydroxyl proton and the methoxy oxygen.
- Diaxial (ax, ax): The dihedral angle is 180° . While this minimizes gauche steric interactions, it prevents IMHB formation and suffers from significant 1,3-diaxial strain.

The Cis Isomer (Kinetic/Complex Product)

In the cis isomer, one substituent must be axial while the other is equatorial. The equilibrium exists between (ax, eq) and (eq, ax).

- Conformational Lock: The equilibrium is biased by the A-values (conformational free energy) of the substituents.
 - kcal/mol
 - kcal/mol
- Hydrogen Bonding: Like the trans-diequatorial conformer, the cis isomer possesses a dihedral angle of $\sim 60^\circ$, facilitating IMHB. However, the obligatory axial substituent introduces destabilizing 1,3-diaxial interactions, making the cis isomer generally less stable than the trans-diequatorial form.

Visualization of Conformational Dynamics

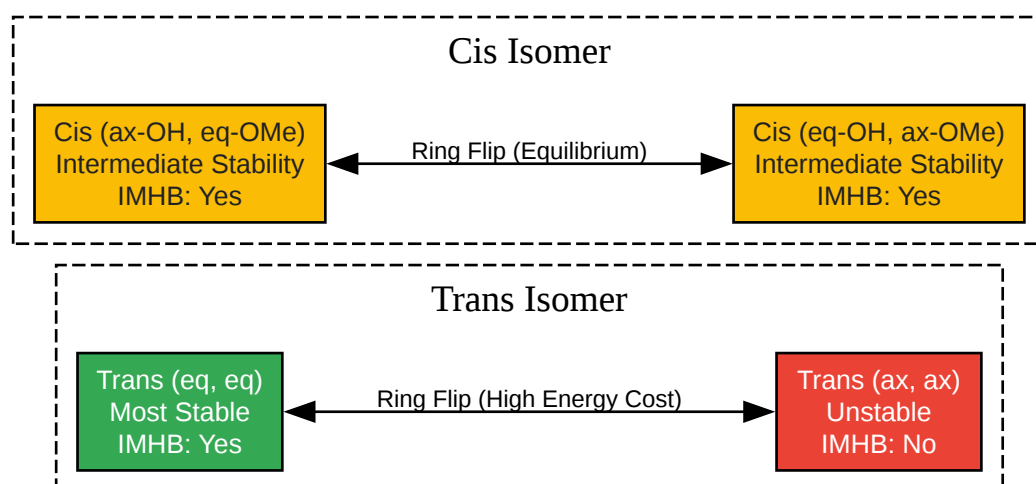

[Click to download full resolution via product page](#)

Figure 1: Conformational equilibrium of 2-methoxycyclohexanol isomers. The trans-diequatorial conformer is stabilized by both steric relief and hydrogen bonding.

Part 2: Synthetic Pathways[2][3]

The synthesis of these isomers relies on exploiting reaction mechanisms that dictate stereoselectivity—specifically, the anti-addition of nucleophiles to epoxides versus the facial selectivity of ketone reductions.

Synthesis of Trans-2-Methoxycyclohexan-1-ol

The industry-standard route involves the ring-opening of cyclohexene oxide. This reaction proceeds via an

mechanism, necessitating anti-attack of the nucleophile.

- Precursor: Cyclohexene Oxide.
- Reagents: Methanol (MeOH), Acid Catalyst ()
or Lewis Acids like ().
- Mechanism:

- Protonation/activation of the epoxide oxygen.
- Backside attack by MeOH at the more substituted/activated carbon (though symmetric in unsubstituted cyclohexene).
- Result: The -OH and -OMe groups end up on opposite faces of the ring.

Protocol 1: Acid-Catalyzed Epoxide Opening

- Dissolve 10 mmol cyclohexene oxide in 20 mL dry MeOH.
- Add 0.1 equiv. conc.
dropwise at 0°C.
- Stir at room temperature for 2 hours (monitor by TLC).
- Quench with sat.
, extract with EtOAc.
- Yield: >90% trans isomer.

Synthesis of Cis-2-Methoxycyclohexan-1-ol

Direct synthesis of the cis isomer is more challenging and typically requires the reduction of 2-methoxycyclohexanone. The stereochemical outcome depends on the reducing agent's size and the reaction temperature.

- Precursor: 2-Methoxycyclohexanone.
- Reagents:
 - Small Hydrides (NaBH₄, LiAlH₄): Tend to yield mixtures favoring the thermodynamic (trans) product or slight cis preference depending on solvent.
 - Bulky Hydrides (L-Selectride): Attack from the less hindered equatorial face, forcing the hydroxyl group into an axial position (forming the cis isomer).

- Alternative Route: Mitsunobu inversion of the trans alcohol (requires protection/deprotection steps).

Protocol 2: L-Selectride Reduction (Kinetic Control)

- Cool a solution of 2-methoxycyclohexanone (5 mmol) in THF to -78°C .
- Add L-Selectride (1.1 equiv) slowly. The bulky hydride approaches from the equatorial trajectory (less hindered).
- Stir for 1 hour at -78°C .
- Oxidative Workup: Add NaOH/H₂O₂ carefully to quench the borane intermediate.
- Result: Enriched cis-**2-methoxycyclohexan-1-ol** (Axial OH).

Synthetic Workflow Diagram

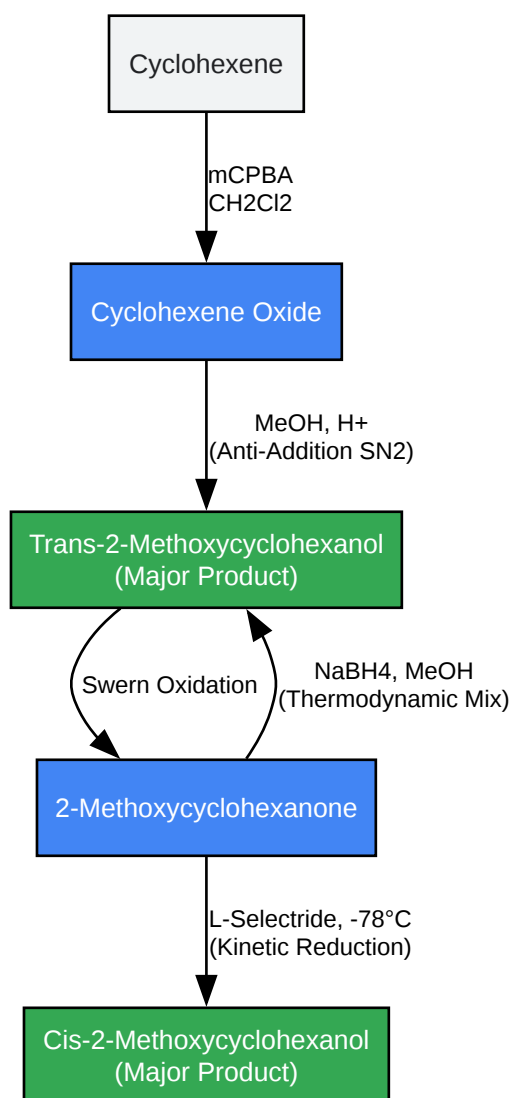

[Click to download full resolution via product page](#)

Figure 2: Divergent synthetic pathways for accessing cis and trans isomers.

Part 3: Analytical Characterization

Distinguishing these isomers relies heavily on NMR spectroscopy, specifically the coupling constants (

) of the methine protons.

Proton NMR (NMR)

The Karplus equation relates the vicinal coupling constant (

) to the dihedral angle (

).

Feature	Trans Isomer	Cis Isomer	Mechanistic Basis
H1/H2 Signal	Axial Protons	Equatorial/Axial Mix	Ring conformation
Coupling ()	8 - 12 Hz	2 - 5 Hz	Dihedral Angle
Splitting Pattern	ddd (Large splitting)	Narrow multiplet	Ax-Ax vs Ax-Eq coupling
Chemical Shift	~3.1 - 3.3 ppm	~3.4 - 3.6 ppm	Equatorial protons are deshielded

- **Trans Isomer:** The H1 and H2 protons are both axial (in the stable diequatorial conformer). The dihedral angle is $\sim 180^\circ$, leading to a large coupling constant (Hz).
- **Cis Isomer:** One proton is axial and the other equatorial. The dihedral angle is $\sim 60^\circ$, resulting in a significantly smaller coupling constant (Hz).

Infrared Spectroscopy (IR)

- **Intramolecular H-Bonding:** Both isomers can form IMHB, but the strength varies.
- **O-H Stretch:**
 - Free OH: $\sim 3600-3650\text{ cm}^{-1}$ (Concentration dependent).
 - Bonded OH (Intramolecular): $\sim 3550-3590\text{ cm}^{-1}$ (Concentration independent).
 - Note: In dilute , the trans-diequatorial isomer shows a distinct red-shifted band due to strong IMHB.

Part 4: Applications in Drug Development

Chiral Building Blocks

2-Methoxycyclohexanol serves as a scaffold for synthesizing complex bioactive molecules. The rigid cyclohexane ring provides a defined spatial arrangement for pharmacophores.

- Kinase Inhibitors: The 1,2-functionalization pattern is mimicked in aminocyclohexanol-based inhibitors.
- Agrochemicals: Intermediates for spirocyclic derivatives used in modern pesticides (e.g., Spirotetramat analogs).^[1]

Solvation & Permeability Models

Because of the distinct lipophilicity profiles of the cis (more compact, potentially higher dipole depending on conformation) and trans isomers, they are used as model substrates to study:

- Membrane Permeability: The ability of IMHB to "hide" the polar hydroxyl group, increasing apparent lipophilicity and passive transport across lipid bilayers.
- Solvation Energy: Validation of computational models (DFT/PCM) for predicting solvation free energies in drug discovery.

References

- Conformational Analysis of 2-Substituted Cyclohexanols Source: Journal of the Chemical Society, Perkin Transactions 2 Context: Detailed thermodynamic analysis of diequatorial vs diaxial equilibria. URL:[\[Link\]](#)
- Selective Conversion of Cyclohexene to 2-Methoxycyclohexanol over Molybdenum Oxide Source: Industrial & Engineering Chemistry Research (2023) Context:[\[2\]](#)[\[3\]](#)[\[4\]](#)[\[5\]](#)[\[6\]](#)[\[7\]](#) Catalytic routes for high-yield synthesis of the trans isomer.^[4] URL:[\[Link\]](#)
- NMR Coupling Constants and Stereochemistry Source: Chemistry LibreTexts / Karplus Relationship Context: Fundamental basis for distinguishing cis/trans isomers via J-coupling. URL:[\[Link\]](#)

- Stereoselective Reduction of Cyclohexanones Source: Journal of the American Chemical Society Context: Methodologies for kinetic (L-Selectride) vs thermodynamic reduction. URL: [\[Link\]](#)

Need Custom Synthesis?

BenchChem offers custom synthesis for rare earth carbides and specific isotopic labeling.

Email: info@benchchem.com or [Request Quote Online](#).

Sources

- [1. A Process For The Synthesis Of 4 Methoxycyclohexanone \[quickcompany.in\]](#)
- [2. beilstein-journals.org \[beilstein-journals.org\]](#)
- [3. researchgate.net \[researchgate.net\]](#)
- [4. researchgate.net \[researchgate.net\]](#)
- [5. youtube.com \[youtube.com\]](#)
- [6. chem.libretexts.org \[chem.libretexts.org\]](#)
- [7. chem.libretexts.org \[chem.libretexts.org\]](#)
- To cite this document: BenchChem. [Technical Guide: The cis and trans Isomers of 2-Methoxycyclohexan-1-ol[1]]. BenchChem, [2026]. [Online PDF]. Available at: [\[https://www.benchchem.com/product/b6278834/docs#technical-guide-the-cis-and-trans-isomers-of-2-methoxycyclohexan-1-ol-1\]](https://www.benchchem.com/product/b6278834/docs#technical-guide-the-cis-and-trans-isomers-of-2-methoxycyclohexan-1-ol-1)

Disclaimer & Data Validity:

The information provided in this document is for Research Use Only (RUO) and is strictly not intended for diagnostic or therapeutic procedures. While BenchChem strives to provide accurate protocols, we make no warranties, express or implied, regarding the fitness of this product for every specific experimental setup.

Technical Support: The protocols provided are for reference purposes. Unsure if this reagent suits your experiment?

Need Industrial/Bulk Grade? [Request Custom Synthesis Quote](#)

BenchChem

Our mission is to be the trusted global source of essential and advanced chemicals, empowering scientists and researchers to drive progress in science and industry.

Contact

Address: 3281 E Guasti Rd

Ontario, CA 91761, United States

Phone: (601) 213-4426

Email: info@benchchem.com

[Contact our Ph.D. Support Team for a compatibility check](#)