

Application Note: Palladium-Catalyzed Cross-Coupling Reactions of Chlorinated Benzonitriles

Author: BenchChem Technical Support Team. **Date:** April 2026

Compound of Interest

Compound Name: *2-chloro-4-fluoro-6-methylbenzonitrile*

CAS No.: 1805520-76-6

Cat. No.: B6273176

[Get Quote](#)

Introduction

Aromatic nitriles are pivotal structural motifs found in a vast array of functional molecules, including pharmaceuticals, agrochemicals, and advanced materials.^[1] Chlorinated benzonitriles, in particular, serve as versatile and cost-effective building blocks for synthesizing more complex molecular architectures. However, the inherent stability of the carbon-chlorine (C-Cl) bond presents a significant challenge for synthetic chemists.^[2] Unlike their more reactive bromo or iodo counterparts, aryl chlorides are notoriously difficult to activate, often requiring harsh reaction conditions.

The advent of sophisticated palladium-catalyzed cross-coupling reactions has revolutionized the use of aryl chlorides.^{[3][4]} By employing advanced catalyst systems, typically featuring bulky, electron-rich phosphine ligands or N-heterocyclic carbenes (NHCs), the once-inert C-Cl bond can be efficiently activated, enabling a wide range of C-C, C-N, and C-O bond formations under increasingly mild conditions.^{[3][4][5]}

This guide provides an in-depth analysis and field-proven protocols for the most critical palladium-catalyzed cross-coupling reactions involving chlorinated benzonitriles. We will delve into the causality behind experimental choices, offering researchers, scientists, and drug development professionals the necessary tools to successfully leverage these powerful transformations.

The Core Challenge: Oxidative Addition to the C-Cl Bond

The general catalytic cycle for most palladium-catalyzed cross-coupling reactions begins with the oxidative addition of the aryl halide to a Pd(0) complex.^{[4][6]} This step, which involves the cleavage of the C-Cl bond and formation of an Ar-Pd(II)-Cl intermediate, is frequently the rate-determining step of the entire catalytic process.^{[7][8]} The strength of the C-Cl bond makes this step energetically demanding.

The key to overcoming this barrier lies in the design of the ligand sphere around the palladium center.

- **Bulky, Electron-Rich Ligands:** Ligands such as the dialkylbiarylphosphines (e.g., SPhos, XPhos) and sterically hindered ferrocenyl phosphines increase the electron density on the Pd(0) center.^{[3][4]} This enhanced electron density facilitates the insertion of the metal into the C-Cl bond, thereby lowering the activation energy for oxidative addition.^[9]
- **N-Heterocyclic Carbenes (NHCs):** NHCs are strong σ -donors that form highly stable and active palladium complexes.^{[10][11]} These catalysts have demonstrated remarkable efficiency in activating aryl chlorides for various coupling reactions, including Suzuki-Miyaura couplings.^[10]

The mechanism of oxidative addition itself can vary, with possibilities including a three-centered concerted mechanism or a more polar nucleophilic displacement pathway, depending on the substrate, ligand, and coordination number of the palladium complex.^{[12][13][14]} For electron-deficient substrates like chlorobenzonitriles, the reaction is often facilitated, yet the choice of an appropriate, highly active catalyst system remains paramount.

Suzuki-Miyaura Coupling: Forging C-C Bonds

The Suzuki-Miyaura reaction is a cornerstone of modern organic synthesis, enabling the formation of biaryl structures from aryl halides and organoboron reagents.^[15] Its tolerance of a wide range of functional groups and the low toxicity of its boron-based reagents make it exceptionally valuable.^[15]

Catalytic Cycle and Mechanistic Considerations

The reaction proceeds through a well-established catalytic cycle involving three key steps:

- **Oxidative Addition:** The active Pd(0) catalyst inserts into the C-Cl bond of the chlorobenzonitrile.
- **Transmetalation:** The organic group from the activated boronic acid (or ester) is transferred to the palladium(II) center, displacing the halide. This step requires a base to activate the organoboron species.^[10]
- **Reductive Elimination:** The two organic partners on the palladium center couple, forming the new C-C bond and regenerating the Pd(0) catalyst.^[6]

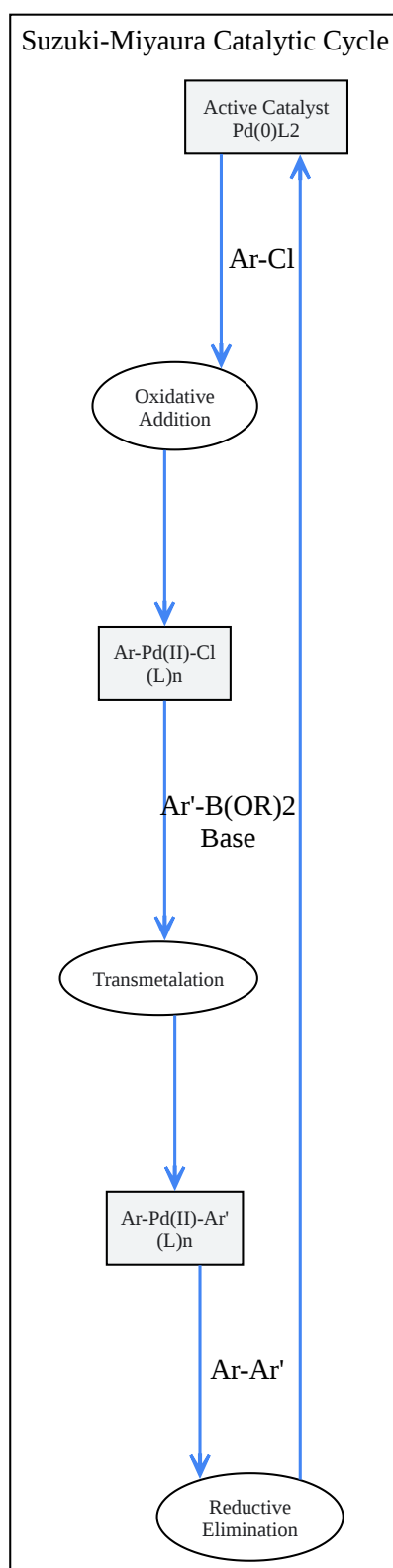

[Click to download full resolution via product page](#)

Caption: Generalized catalytic cycle for the Suzuki-Miyaura reaction.

Data Summary: Suzuki Coupling of Chlorobenzonitriles

Substrate	Coupling Partner	Pd Source (mol%)	Ligand (mol%)	Base	Solvent	Temp (°C)	Yield (%)	Reference
3-Chlorobenzonitrile	Phenylboronic acid	Pd(OAc) ₂ (2)	Ferrocenyl phosphine 17 (4)	K ₃ PO ₄	Toluene	100	92	[3]
4-Chlorobenzonitrile	Phenylboronic acid	[Pd(IMes)(allyl)Cl] (2)	-	K ₂ CO ₃	Dioxane/H ₂ O	80	89	[16]
4-Chlorotoluene	Phenylboronic acid	Pd(OAc) ₂ (0.5-2)	DavePhos 1 (0.7-3)	K ₃ PO ₄	Toluene	RT	94	[3]

Protocol: Suzuki-Miyaura Coupling of 4-Chlorobenzonitrile

This protocol is adapted from a procedure utilizing an N-heterocyclic carbene (NHC) palladium complex.[16]

Materials:

- 4-Chlorobenzonitrile
- Phenylboronic acid
- [Pd(IMes)(allyl)Cl] catalyst
- Potassium Carbonate (K₂CO₃), finely ground
- 1,4-Dioxane, anhydrous

- Deionized Water, degassed
- Standard glassware for inert atmosphere reactions (Schlenk flask, condenser)
- Magnetic stirrer and heating mantle

Procedure:

- **Reaction Setup:** To a dry Schlenk flask equipped with a magnetic stir bar, add 4-chlorobenzonitrile (1.0 mmol, 1.0 equiv), phenylboronic acid (1.2 mmol, 1.2 equiv), and K₂CO₃ (2.0 mmol, 2.0 equiv).
- **Catalyst Addition:** In a glovebox or under a positive flow of inert gas, add the [Pd(IMes)(allyl)Cl] catalyst (0.02 mmol, 2 mol%).
- **Solvent Addition:** Add anhydrous 1,4-dioxane (3 mL) and degassed deionized water (0.5 mL) via syringe.
- **Inert Atmosphere:** Seal the flask and purge with argon or nitrogen for 10-15 minutes while stirring.
- **Reaction:** Heat the reaction mixture to 80 °C under the inert atmosphere. Monitor the reaction progress by TLC or GC-MS. The reaction is typically complete within 4-12 hours.
- **Workup:** After cooling to room temperature, dilute the mixture with ethyl acetate (20 mL) and water (10 mL). Separate the organic layer, and extract the aqueous layer with ethyl acetate (2 x 10 mL).
- **Purification:** Combine the organic layers, wash with brine, dry over anhydrous Na₂SO₄, and concentrate under reduced pressure. The crude product can be purified by column chromatography on silica gel (e.g., using a hexane/ethyl acetate gradient) to yield the pure 4-cyanobiphenyl.

Buchwald-Hartwig Amination: Constructing C-N Bonds

The Buchwald-Hartwig amination is a powerful method for forming C-N bonds, enabling the synthesis of aryl amines from aryl halides.[17][18] This reaction has broad applications in medicinal chemistry, where the aryl amine moiety is a common feature.[19]

Catalytic Cycle and Mechanistic Considerations

The catalytic cycle is similar to the Suzuki coupling but involves an amine nucleophile.[6][20] A strong, non-nucleophilic base (e.g., NaOt-Bu, K₃PO₄) is crucial for deprotonating the amine, which allows it to coordinate to the palladium center and facilitates the final reductive elimination step.[20] The choice of ligand is critical, with bulky biaryl phosphines being particularly effective for coupling aryl chlorides.[20]

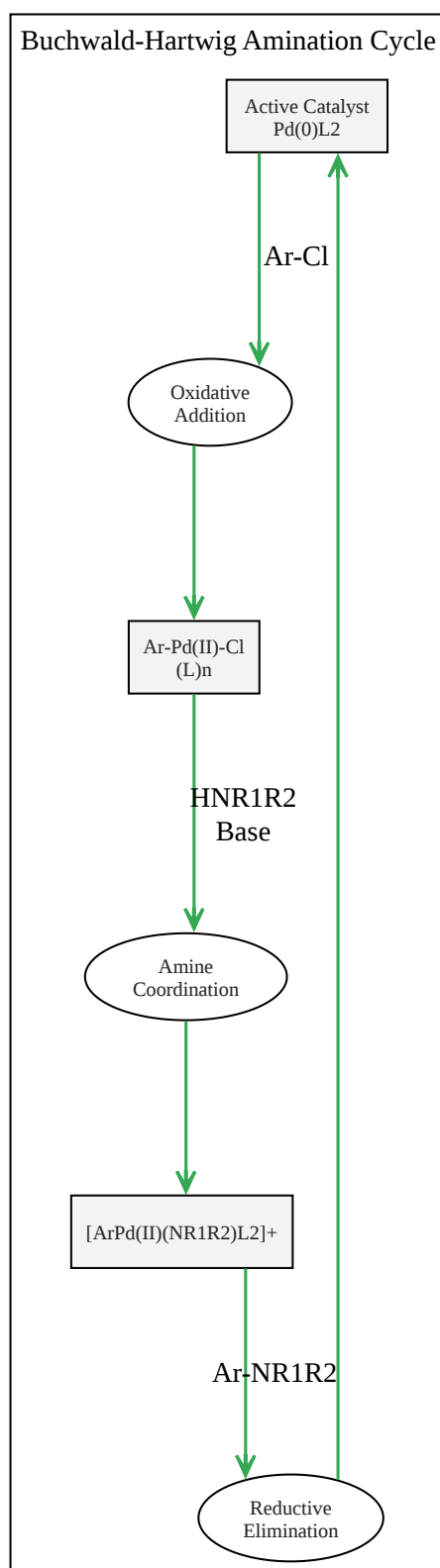

[Click to download full resolution via product page](#)

Caption: Catalytic cycle for the Buchwald-Hartwig amination.

Data Summary: Amination of Aryl Chlorides

While specific examples for chlorobenzonitriles are less common in introductory reviews, the conditions developed for other electron-deficient aryl chlorides are directly applicable.

Substrate	Amine	Pd Source (mol%)	Ligand (mol%)	Base	Solvent	Temp (°C)	Yield (%)	Reference
4-Chlorotoluene	Morpholine	Pd(OAc) ₂ (1)	XPhos (1.5)	NaOt-Bu	Toluene	100	98	[4]
4-Chloroanisole	Aniline	Pd ₂ (dba) ₃ (1)	CyPF-tBu (2.2)	NaOt-Bu	Dioxane	80	>95	[21]
Chlorobenzene	Diphenylamine	Pd(OAc) ₂ (2)	YPhos (4)	K ₃ PO ₄	Toluene	50	35	[22]

Protocol: General Procedure for Buchwald-Hartwig Amination

This generalized protocol is based on catalyst systems known to be effective for aryl chlorides. [4][21]

Materials:

- Chlorobenzonitrile derivative
- Primary or secondary amine
- Palladium precatalyst (e.g., Pd(OAc)₂, Pd₂(dba)₃)
- Bulky phosphine ligand (e.g., XPhos, SPhos)
- Sodium tert-butoxide (NaOt-Bu)
- Anhydrous toluene or dioxane

- Standard glassware for inert atmosphere reactions

Procedure:

- **Reaction Setup:** In a glovebox, add the palladium precatalyst (1-2 mol%) and the phosphine ligand (1.5-4 mol%) to a dry Schlenk tube. Add anhydrous toluene (1 mL) and stir for 5 minutes.
- **Reagent Addition:** Add the chlorobenzonitrile (1.0 mmol, 1.0 equiv), the amine (1.2 mmol, 1.2 equiv), and NaOt-Bu (1.4 mmol, 1.4 equiv).
- **Solvent and Sealing:** Add additional anhydrous solvent (total volume ~3-4 mL), seal the tube with a Teflon screw cap, and remove it from the glovebox.
- **Reaction:** Vigorously stir the reaction mixture in a heating block at 80-110 °C for 12-24 hours.
- **Workup:** After cooling, dilute the reaction with ethyl acetate and filter through a short pad of Celite to remove inorganic salts.
- **Purification:** Concentrate the filtrate and purify the residue by flash column chromatography on silica gel to obtain the desired aryl amine product.

Sonogashira Coupling: Introducing Alkynes

The Sonogashira reaction couples terminal alkynes with aryl halides to produce arylalkynes and conjugated enynes.^[23] The reaction traditionally uses a dual catalyst system of palladium and a copper(I) salt, although copper-free variants have been developed to prevent the undesired homocoupling of alkynes (Glaser coupling).^[24]

Catalytic Cycle and Mechanistic Considerations

The mechanism involves two interconnected cycles:

- **Palladium Cycle:** Similar to other cross-couplings, it involves oxidative addition of the aryl chloride to Pd(0) and reductive elimination.
- **Copper Cycle:** Copper(I) reacts with the terminal alkyne in the presence of a base to form a copper(I) acetylide intermediate. This species then undergoes transmetalation with the Ar-

Pd(II)-Cl complex.[24]

Activating aryl chlorides for Sonogashira coupling is particularly challenging and often requires higher temperatures and specialized, highly active catalyst systems.[25][26]

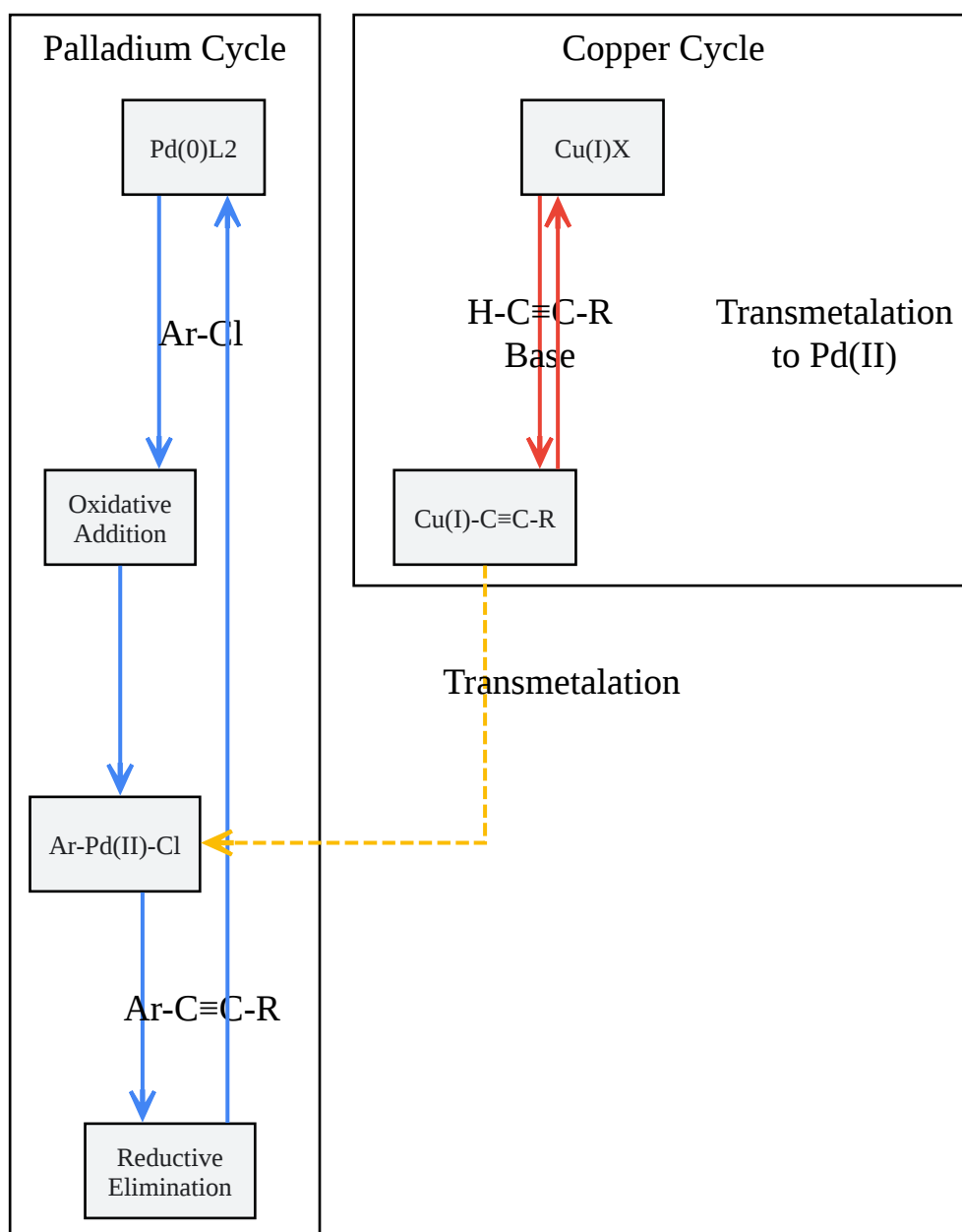

[Click to download full resolution via product page](#)

Caption: Interconnected catalytic cycles of the Sonogashira reaction.

Protocol: General Procedure for Sonogashira Coupling

This protocol is a general method for coupling challenging aryl chlorides.^[26]

Materials:

- Chlorobenzonitrile derivative
- Terminal alkyne
- PdCl₂(PPh₃)₂ or similar Pd(II) source
- Copper(I) iodide (CuI)
- Triphenylphosphine (PPh₃)
- A strong amine base (e.g., triethylamine (TEA), diisopropylamine (DIPA))
- Anhydrous, degassed solvent (e.g., DMF, toluene)

Procedure:

- **Reaction Setup:** To a dry Schlenk flask, add the chlorobenzonitrile (1.0 mmol, 1.0 equiv), PdCl₂(PPh₃)₂ (0.03 mmol, 3 mol%), and CuI (0.06 mmol, 6 mol%).
- **Inert Atmosphere:** Seal the flask, and evacuate and backfill with an inert gas (e.g., argon) three times.
- **Reagent Addition:** Under a positive pressure of inert gas, add anhydrous, degassed solvent (5 mL) followed by the amine base (3.0 mmol, 3.0 equiv) and the terminal alkyne (1.5 mmol, 1.5 equiv) via syringe.
- **Reaction:** Heat the mixture to 80-120 °C. Monitor the reaction by TLC or GC-MS until the starting material is consumed.
- **Workup:** Cool the reaction to room temperature and quench with saturated aqueous NH₄Cl solution. Extract the product with an organic solvent like ethyl acetate or diethyl ether.

- Purification: Combine the organic layers, dry over anhydrous MgSO_4 , concentrate, and purify by flash column chromatography.

Palladium-Catalyzed Cyanation

While the starting material is already a nitrile, this reaction is crucial for introducing additional nitrile groups onto a chlorinated benzonitrile core (e.g., from a dichlorobenzonitrile). Modern methods have shifted towards using less toxic and more environmentally friendly cyanide sources than traditional reagents like KCN or NaCN.^[27] Potassium hexacyanoferrate(II) ($\text{K}_4[\text{Fe}(\text{CN})_6]$) has emerged as a robust and safer alternative.^{[1][28][29]}

Protocol: Mild Cyanation of an Aryl Chloride

This highly efficient protocol was developed by Kwong and co-workers and operates at an exceptionally mild temperature for an aryl chloride cyanation.^{[1][28]}

Materials:

- Chlorinated benzonitrile substrate (e.g., 2,4-dichlorobenzonitrile)
- Potassium hexacyanoferrate(II) trihydrate ($\text{K}_4[\text{Fe}(\text{CN})_6] \cdot 3\text{H}_2\text{O}$)
- Palladium(II) acetate ($\text{Pd}(\text{OAc})_2$)
- CM-phos ligand (dicyclohexyl(2',4',6'-trimethoxy-[1,1'-biphenyl]-2-yl)phosphine)
- Potassium carbonate (K_2CO_3)
- Acetonitrile (MeCN) and deionized water

Procedure:

- Reaction Setup: In a reaction vial, combine the aryl chloride (1.0 mmol, 1.0 equiv), $\text{K}_4[\text{Fe}(\text{CN})_6] \cdot 3\text{H}_2\text{O}$ (0.5 mmol, 0.5 equiv), $\text{Pd}(\text{OAc})_2$ (0.02 mmol, 2 mol%), CM-phos (0.04 mmol, 4 mol%), and K_2CO_3 (0.125 mmol, 0.125 equiv).
- Solvent Addition: Add a 1:1 mixture of MeCN/water (2 mL total volume).

- Reaction: Seal the vial and stir the mixture at 70 °C for 18 hours. The presence of water is critical to facilitate the dissolution of the cyanide source.[1]
- Workup: After cooling, dilute the mixture with water and extract with ethyl acetate (3 x 15 mL).
- Purification: Combine the organic extracts, wash with brine, dry over Na₂SO₄, and concentrate under reduced pressure. Purify the crude product by silica gel chromatography.

General Experimental Workflow

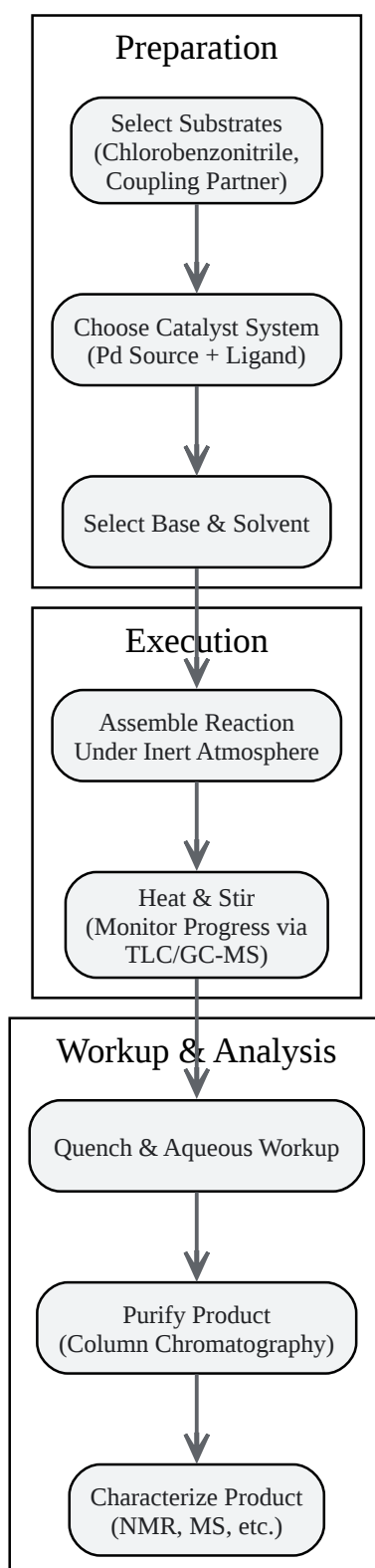

[Click to download full resolution via product page](#)

Caption: A typical workflow for palladium-catalyzed cross-coupling.

References

- Current time inform
- Yeung, P. Y., So, C. M., Lau, C. P., & Kwong, F. Y. (2011). A Mild and Efficient Palladium-Catalyzed Cyanation of Aryl Chlorides with $K_4[Fe(CN)_6]$. *Organic Letters*, 13(4), 648–651. ACS Publications. [[Link](#)]
- Billingsley, K. L., & Buchwald, S. L. (2019). Ligand-supported palladium-catalyzed cross-coupling reactions of (hetero) aryl chlorides. *Journal of the American Chemical Society*. [[Link](#)]
- Yeung, P. Y., So, C. M., Lau, C. P., & Kwong, F. Y. (2011). A Mild and Efficient Palladium-Catalyzed Cyanation of Aryl Chlorides with $K_4[Fe(CN)_6]$. *Organic Letters*, 13(4), 648–651. [[Link](#)]
- Senecal, T. D., Shu, W., & Buchwald, S. L. (2013). A General, Practical Palladium-Catalyzed Cyanation of (Hetero)Aryl Chlorides and Bromides. *Angewandte Chemie International Edition*, 52(38), 10035–10039. Wiley Blackwell. [[Link](#)]
- Soley, J. N., & Veticatt, M. J. (2024). Oxidative Addition of (Hetero)aryl (Pseudo)halides at Palladium(0): Origin and Significance of Divergent Mechanisms. *ChemRxiv*. [[Link](#)]
- Liu, L., et al. (2011). A Simple and Efficient Protocol for Suzuki Coupling Reactions of Aryl Chlorides and Aryl Bromides in Aqueous DMF. *ResearchGate*. [[Link](#)]
- Anderson, K. W., & Buchwald, S. L. (2005). Palladium-Catalyzed Cyanation Reactions of Aryl Chlorides. *Angewandte Chemie International Edition*, 44(38), 6173-6177. [[Link](#)]
- Bardes, E. E., & Buchwald, S. L. (2007). Palladium-Catalyzed Suzuki-Miyaura Cross-coupling Reactions Employing Dialkylbiaryl Phosphine Ligands. *PMC*. [[Link](#)]
- S. S., & K., S. (2020). Recent advances and prospects in the palladium-catalyzed cyanation of aryl halides. *RSC Advances*. [[Link](#)]
- Soley, J. N., & Veticatt, M. J. (2024). Oxidative Addition of (Hetero)aryl (Pseudo)halides at Palladium(0): Origin and Significance of Divergent Mechanisms. *Journal of the American Chemical Society*, 146(28), 19249–19260. [[Link](#)]

- Sołoducho, J., et al. (2013). Recent Advances of Modern Protocol for C-C Bonds—The Suzuki Cross-Coupling. *International Journal of Organic Chemistry*. [[Link](#)]
- Bickelhaupt, F. M., & de Jong, G. T. (2001). Mechanistic Pathways for Oxidative Addition of Aryl Halides to Palladium(0) Complexes: A DFT Study. *ResearchGate*. [[Link](#)]
- Powers, D. C., & Ritter, T. (2024). Mapping the mechanisms of oxidative addition in cross-coupling reactions catalysed by phosphine-ligated Ni(0). *Nature Chemistry*. [[Link](#)]
- Li, G. Y. (2003). Palladium/P,O-Ligand-Catalyzed Suzuki Cross-Coupling Reactions of Arylboronic Acids and Aryl Chlorides. Isolation and Structural Characterization of (P,O)-Pd(dba) Complex. *The Journal of Organic Chemistry*, 68(14), 5413–5416. ACS Publications. [[Link](#)]
- Lu, J., Donnecke, S., Paci, I., & Leitch, D. C. (2022). A reactivity model for oxidative addition to palladium enables quantitative predictions for catalytic cross-coupling reactions. *Chemical Science*, 13(12), 3463-3471. [[Link](#)]
- Hartwig, J. F., & Mann, G. (2002). Highly Efficient and Functional-Group-Tolerant Catalysts for the Palladium-Catalyzed Coupling of Aryl Chlorides with Thiols. *Angewandte Chemie International Edition*, 41(22), 4372-4375. [[Link](#)]
- Zhang, Z., et al. (2024). Palladium-Catalyzed Coupling of Aryl Chlorides with Secondary Phosphines to Construct Unsymmetrical Tertiary Phosphines. *Organic Letters*. ACS Publications. [[Link](#)]
- Alonso, D. A., & Nájera, C. (2018). Solid-Supported Palladium Catalysts in Sonogashira Reactions: Recent Developments. *Molecules*, 23(5), 1145. [[Link](#)]
- Liu, L., et al. (2011). A simple and efficient protocol for Suzuki coupling reactions of aryl chlorides and aryl bromides in aqueous DMF. *Semantic Scholar*. [[Link](#)]
- Zhang, C., Huang, J., Trudell, M. L., & Nolan, S. P. (1999). Palladium-imidazol-2-ylidene complexes as catalysts for facile and efficient Suzuki cross-coupling reactions of aryl chlorides with arylboronic acids. *The Journal of Organic Chemistry*. [[Link](#)]

- Dunsford, J. J., & Doyle, A. G. (2022). Reductive Arylation of Nitroarenes with Chloroarenes: Reducing Conditions Enable New Reactivity from Palladium Catalysts. PMC. [\[Link\]](#)
- Wikipedia contributors. (2024). Buchwald–Hartwig amination. Wikipedia. [\[Link\]](#)
- Bedford, R. B., et al. (2024). The iron-catalysed Suzuki coupling of aryl chlorides. Nature Catalysis. [\[Link\]](#)
- Hassan, A. A., & El-Sheref, E. M. (2025). Palladium-Catalyzed Cross-Coupling Reactions in the Synthesis of Pharmaceuticals. Current Organic Synthesis. [\[Link\]](#)
- Ghosh, A., et al. (2020). Highly efficient aqueous-phase Sonogashira coupling catalyzed by Pd-PEEPSI/PPh₃ under aerobic condition. Journal of Chemical Sciences. [\[Link\]](#)
- Xia, Q., et al. (2018). Towards Environmentally Friendlier Suzuki-Miyaura Reactions with Pd-NHC (NHC = N-Heterocyclic Carbene) Complexes. Royal Society of Chemistry. [\[Link\]](#)
- Takise, R., Muto, K., & Yamaguchi, J. (2022). Synthesis and Properties of Pyridine-Fused Triazolylidene–Palladium: Catalyst for Cross-Coupling Using Chloroarenes and Nitroarenes. The Journal of Organic Chemistry, 87(18), 12108–12117. ACS Publications. [\[Link\]](#)
- Wikipedia contributors. (2024). Sonogashira coupling. Wikipedia. [\[Link\]](#)
- Wikipedia contributors. (2024). Heck reaction. Wikipedia. [\[Link\]](#)
- de Vries, J. G. (2017). Heck Reaction—State of the Art. Molecules, 22(9), 1494. [\[Link\]](#)
- Spencer, J. (2010). Broadening Application of the Heck Reaction via in-situ Formation of Olefins. The University of Liverpool Repository. [\[Link\]](#)
- Sharma, P., & Kumar, A. (2019). Microwave-Assisted Palladium-Catalyzed Cross-Coupling Reactions: Generation of Carbon–Carbon Bond. Catalysts, 10(1), 16. [\[Link\]](#)
- Buchwald-Hartwig Cross-Coupling. (2021). J&K Scientific LLC. [\[Link\]](#)
- Hassan, A. A., & El-Sheref, E. M. (2018). Application of Palladium-Catalyzed Cross-Coupling Reactions in Organic Synthesis. Current Organic Synthesis. [\[Link\]](#)

- What are the best catalysts for Sonogashira Couplings for use with Chloroaromatics? (2014). ResearchGate. [\[Link\]](#)
- Chemistry LibreTexts. (2023). Buchwald-Hartwig Amination. [\[Link\]](#)
- Kaur, N., & Kishore, D. (2015). Metal–N-Heterocyclic Carbene Complexes in Buchwald–Hartwig Amination Reactions. Chemical Reviews. [\[Link\]](#)
- Chemistry LibreTexts. (2024). Sonogashira Coupling. [\[Link\]](#)
- Overcoming challenges in the palladium-catalyzed synthesis of electron deficient ortho-substituted aryl acetonitriles. (2011). PubMed. [\[Link\]](#)
- Wikipedia contributors. (2024). Suzuki reaction. Wikipedia. [\[Link\]](#)
- Heck Reaction. Organic Chemistry Portal. [\[Link\]](#)
- Suzuki Coupling. Suzuki-Miyaura Reaction: Mechanism, Experimental Procedure, and Set Up. (2025). YouTube. [\[Link\]](#)
- The Suzuki Reaction. Andrew G Myers Research Group. [\[Link\]](#)
- Aksoy, M., et al. (2013). Palladium-Catalyzed Heck Coupling Reaction of Aryl Bromides in Aqueous Media Using Tetrahydropyrimidinium Salts as Carbene Ligands. PMC. [\[Link\]](#)

Need Custom Synthesis?

BenchChem offers custom synthesis for rare earth carbides and specific isotopic labeling.

Email: info@benchchem.com or [Request Quote Online](#).

Sources

1. pubs.acs.org [pubs.acs.org]
2. [Palladium-Catalyzed Cross-Coupling Reactions of Chlorobenzene: Latest Research, Challenges & Breakthroughs in China | Expert Analysis & Insights 2024](#) [[chlorobenzene.ltd](#)]
3. tandfonline.com [tandfonline.com]

- [4. Palladium-Catalyzed Suzuki-Miyaura Cross-coupling Reactions Employing Dialkylbiaryl Phosphine Ligands - PMC \[pmc.ncbi.nlm.nih.gov\]](#)
- [5. Heck Reaction—State of the Art | MDPI \[mdpi.com\]](#)
- [6. Chemical Insights | How to Wisely Design Conditions for Buchwald-Hartwig Couplings ? - RCS Research Chemistry Services \[rcs.wuxiapptec.com\]](#)
- [7. researchgate.net \[researchgate.net\]](#)
- [8. A reactivity model for oxidative addition to palladium enables quantitative predictions for catalytic cross-coupling reactions - Chemical Science \(RSC Publishing\) DOI:10.1039/D2SC00174H \[pubs.rsc.org\]](#)
- [9. Recent Advances of Modern Protocol for C-C Bonds—The Suzuki Cross-Coupling \[scirp.org\]](#)
- [10. Suzuki Coupling \[organic-chemistry.org\]](#)
- [11. d-nb.info \[d-nb.info\]](#)
- [12. chemrxiv.org \[chemrxiv.org\]](#)
- [13. Oxidative Addition of \(Hetero\)aryl \(Pseudo\)halides at Palladium\(0\): Origin and Significance of Divergent Mechanisms - PubMed \[pubmed.ncbi.nlm.nih.gov\]](#)
- [14. Mapping the mechanisms of oxidative addition in cross-coupling reactions catalysed by phosphine-ligated Ni\(0\) - PMC \[pmc.ncbi.nlm.nih.gov\]](#)
- [15. Suzuki reaction - Wikipedia \[en.wikipedia.org\]](#)
- [16. rsc.org \[rsc.org\]](#)
- [17. Buchwald–Hartwig amination - Wikipedia \[en.wikipedia.org\]](#)
- [18. chem.libretexts.org \[chem.libretexts.org\]](#)
- [19. Reductive Arylation of Nitroarenes with Chloroarenes: Reducing Conditions Enable New Reactivity from Palladium Catalysts - PMC \[pmc.ncbi.nlm.nih.gov\]](#)
- [20. jk-sci.com \[jk-sci.com\]](#)
- [21. Highly Efficient and Functional-Group-Tolerant Catalysts for the Palladium-Catalyzed Coupling of Aryl Chlorides with Thiols | The Hartwig Group \[hartwig.cchem.berkeley.edu\]](#)
- [22. pubs.acs.org \[pubs.acs.org\]](#)
- [23. chem.libretexts.org \[chem.libretexts.org\]](#)
- [24. Sonogashira coupling - Wikipedia \[en.wikipedia.org\]](#)
- [25. mdpi.com \[mdpi.com\]](#)

- [26. researchgate.net \[researchgate.net\]](#)
- [27. Recent advances and prospects in the palladium-catalyzed cyanation of aryl halides - PMC \[pmc.ncbi.nlm.nih.gov\]](#)
- [28. A Mild and Efficient Palladium-Catalyzed Cyanation of Aryl Chlorides with K₄\[Fe\(CN\)₆\] \[organic-chemistry.org\]](#)
- [29. researchgate.net \[researchgate.net\]](#)
- To cite this document: BenchChem. [Application Note: Palladium-Catalyzed Cross-Coupling Reactions of Chlorinated Benzonitriles]. BenchChem, [2026]. [Online PDF]. Available at: [\[https://www.benchchem.com/product/b6273176/docs#application-note-palladium-catalyzed-cross-coupling-reactions-of-chlorinated-benzonitriles\]](https://www.benchchem.com/product/b6273176/docs#application-note-palladium-catalyzed-cross-coupling-reactions-of-chlorinated-benzonitriles)

Disclaimer & Data Validity:

The information provided in this document is for Research Use Only (RUO) and is strictly not intended for diagnostic or therapeutic procedures. While BenchChem strives to provide accurate protocols, we make no warranties, express or implied, regarding the fitness of this product for every specific experimental setup.

Technical Support: The protocols provided are for reference purposes. Unsure if this reagent suits your experiment?

Need Industrial/Bulk Grade? [Request Custom Synthesis Quote](#)

BenchChem

Our mission is to be the trusted global source of essential and advanced chemicals, empowering scientists and researchers to drive progress in science and industry.

Contact

Address: 3281 E Guasti Rd
Ontario, CA 91761, United States
Phone: (601) 213-4426
Email: info@benchchem.com

Contact our Ph.D. Support Team for a compatibility check