

Comparative Guide: Bifunctional Probes for Chemical Proteomics

Author: BenchChem Technical Support Team. **Date:** April 2026

Compound of Interest

Compound Name: 4-azido-3-bromobenzonitrile

CAS No.: 1557461-09-2

Cat. No.: B6271206

[Get Quote](#)

Activity-Based Probes (ABPs) vs. Photo-Affinity Probes (PALs)

Executive Summary

In chemical biology and drug discovery, defining the "interactome" of a small molecule is critical for validating targets and understanding off-target toxicity.[1] Bifunctional probes—molecules equipping a ligand with a reactive group and a reporter handle—are the standard for this task.

This guide objectively compares the two dominant probe architectures: Activity-Based Probes (ABPs) and Photo-Affinity Probes (PALs).[2]

- Choose ABPs when profiling the functional state of enzyme families (e.g., serine hydrolases, kinases, cysteine proteases) where a catalytic nucleophile is available.
- Choose PALs for reversible binders, receptors, or targets lacking catalytic nucleophiles, where binding affinity alone dictates the interaction.

Technical Comparison: Mechanisms & Architectures Activity-Based Probes (ABPs)

Mechanism: ABPs exploit the catalytic machinery of an enzyme.^[3]^[4] They contain an electrophilic "warhead" that reacts specifically with a nucleophilic residue (Ser, Cys, Thr) in the enzyme's active site only when the enzyme is in a functionally active conformation.

- Warhead Chemistry:
 - Fluorophosphonates (FP): Broad-spectrum targeting of Serine Hydrolases.
 - Vinyl Sulfones / Epoxides: Cysteine Proteases.
 - Acyl Phosphates: Kinases (targeting conserved Lysines).
- Causality: The labeling event is mechanism-based. An inhibitor that blocks the active site will prevent ABP labeling, providing a direct readout of target occupancy.

Photo-Affinity Probes (PALs)

Mechanism: PALs rely on thermodynamic binding equilibrium. They incorporate a photoreactive group (photophore) that, upon UV irradiation, generates a highly reactive species (carbene, nitrene, or radical) that crosslinks to any proximal amino acid backbone or side chain.^[5]

- Photophore Comparison:
 - Diazirine (Gold Standard): Small footprint (~75 Da). Activated at ~365 nm (long-wave UV) or 300 nm. Generates a carbene with a short half-life, leading to high crosslinking efficiency with minimal non-specific labeling.
 - Benzophenone: Activated at 350-360 nm.^[6] Generates a triplet diradical. Pros: Reversible excitation (if no bond forms, it relaxes and can be re-excited). Cons: Bulky; requires long irradiation times, increasing sample heating and non-specific background.
 - Aryl Azide: Activated at <300 nm (UV-B/C). Cons: UV damage to biological samples; nitrene intermediate can undergo ring expansion, reducing yield.

Reporter Strategies: Direct vs. Two-Step (Click)

- Direct Tagging: The probe contains a bulky fluorophore (e.g., Rhodamine) or Biotin.
 - Limitation: The tag often sterically hinders cell permeability and protein binding.
- Minimalist (Two-Step): The probe contains a tiny Alkyne or Azide handle.
 - Advantage:^{[1][7][8][9][10][11]} Minimal perturbation of the pharmacophore. Labeling is performed post-lysis via Copper-Catalyzed Azide-Alkyne Cycloaddition (CuAAC). This is the preferred method for live-cell profiling.

Decision Matrix: Performance Metrics

Feature	Activity-Based Probes (ABPs)	Photo-Affinity Probes (PALs)
Target Requirement	Requires active catalytic nucleophile (Enzymes). ^[2]	Requires only binding affinity (Receptors, Scaffolds, Enzymes).
Selectivity Source	Chemical reactivity + Ligand affinity.	Ligand affinity + Proximity.
Covalent Linkage	Specific catalytic residue (e.g., Ser195).	Non-specific proximal residue (C-H insertion).
Background Noise	Low (Reaction requires catalysis).	Moderate to High (Depends on UV time & photophore).
Workflow Complexity	Low (Mix & Incubate).	Medium (Incubate + UV Crosslink).
Primary Utility	Functional profiling; Inhibitor occupancy.	Target ID of reversible binders; Binding site mapping.

Visualization: Mechanism & Workflow

The following diagrams illustrate the mechanistic differences and the standard chemical proteomics workflow.

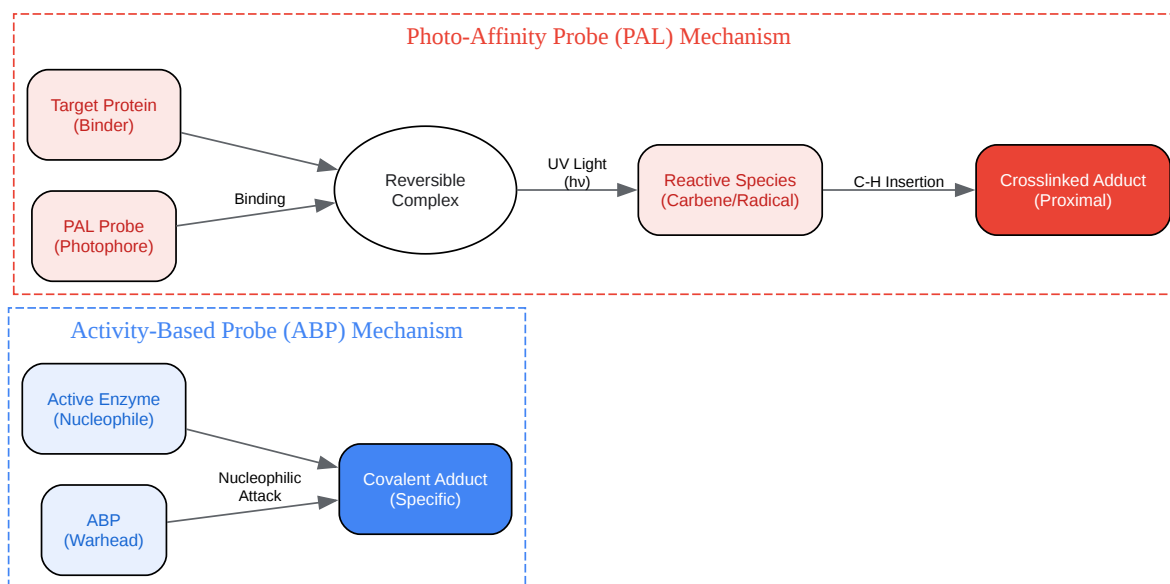

[Click to download full resolution via product page](#)

Figure 1: Mechanistic distinction between ABPs (catalysis-driven) and PALs (affinity + light-driven).

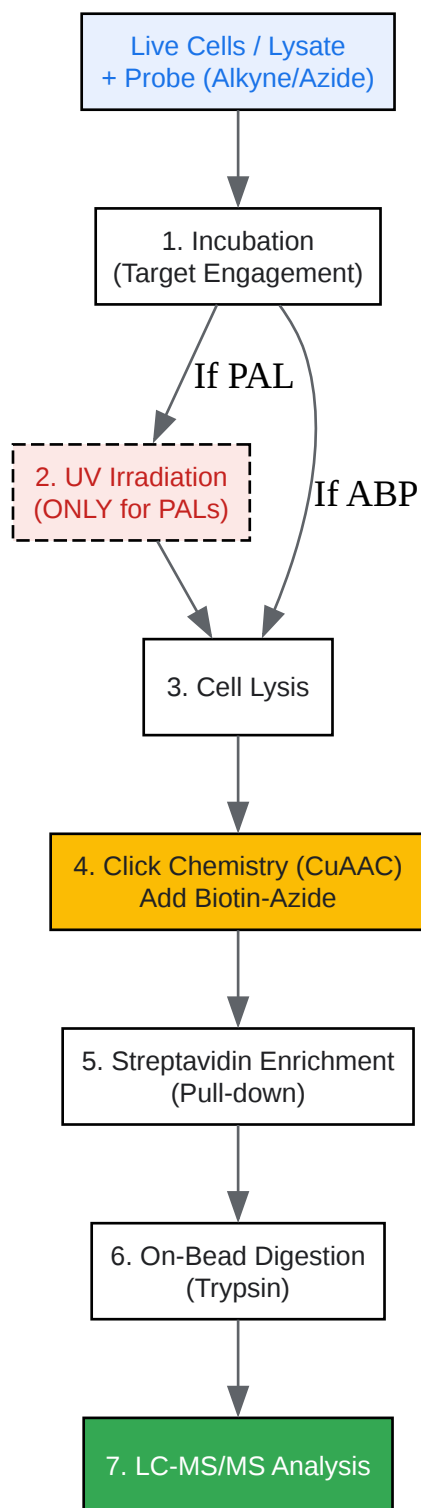

[Click to download full resolution via product page](#)

Figure 2: Standard "Minimalist" Chemical Proteomics Workflow for Target Identification.

Experimental Protocols

Protocol A: Gel-Based Profiling (In-Gel Fluorescence)

Best for: Rapid validation of probe labeling and competition assays (IC50 determination).

Reagents:

- Lysis Buffer: PBS, 1% Triton X-100, Protease Inhibitors.
- Click Mix: TBTA (100 μ M), CuSO₄ (1 mM), TCEP (1 mM), Azide-Rhodamine (25 μ M).

Steps:

- Labeling: Treat cells (or lysate, 1 mg/mL) with Probe (e.g., 1–10 μ M) for 1 hour at 37°C.
 - Control: Pre-incubate with excess competitor (10–20x) for 30 min prior to probe addition.
- Crosslinking (PAL Only): Irradiate samples on ice with UV light (365 nm for Diazirine) for 10 minutes. Critical: Keep samples cold to prevent degradation.
- Lysis: Lyse cells, centrifuge (15,000 x g, 10 min) to clear debris.
- Click Reaction: Add "Click Mix" to 50 μ L lysate. Vortex and incubate for 1 hour at room temperature in the dark.
- Precipitation: Add cold Acetone (4 volumes) or Methanol/Chloroform to precipitate proteins and remove excess free fluorophore. Spin down, wash pellet.
- Visualization: Resuspend in SDS Loading Buffer, boil, resolve on SDS-PAGE. Scan gel on a fluorescence scanner (e.g., Typhoon).

Protocol B: Enrichment & MS-Based Profiling (Target ID)

Best for: Unbiased identification of targets and off-targets.

Reagents:

- Biotin-Azide (or cleavable Dde-Biotin-Azide for cleaner elution).

- Streptavidin Agarose/Magnetic Beads.

Steps:

- Labeling & Lysis: Perform labeling as in Protocol A (scale up to 1–2 mg protein).
- Click Chemistry: React lysate with Biotin-Azide (100 μ M), TBTA, CuSO₄, TCEP for 1.5 hours.
- Precipitation: Methanol/Chloroform precipitation to remove free biotin (crucial to prevent bead saturation).
- Enrichment: Resuspend protein pellet in PBS + 0.2% SDS. Incubate with Streptavidin beads for 2 hours.
- Washing: Stringent washes are required:
 - 1x PBS + 1% SDS (removes non-specific hydrophobic binders).
 - 1x PBS + 4M Urea (unfolds proteins).
 - 3x PBS (removes Urea).
- Digestion: Perform on-bead digestion with Trypsin (overnight, 37°C).
- Analysis: Collect supernatant (peptides), desalt (C18 StageTip), and analyze via LC-MS/MS.
 - Data Processing: Use Label-Free Quantification (LFQ). Compare "Probe" vs. "Probe + Competitor" intensities. True targets show high enrichment ratios (Probe/Comp > 4).

Scientific Integrity & Troubleshooting

- Self-Validating the Protocol:
 - The "No-UV" Control (for PALs): Always include a sample treated with probe but NOT irradiated. If you see labeling here, your probe is reacting thermally (non-specifically) or acting as an electrophile (ABP-like behavior).[9]

- The "Click" Control: Run a sample without the Click catalyst (CuSO₄). Any signal indicates autofluorescence or non-specific binding of the reporter.
- Causality in Probe Design:
 - Use Diazirine over Benzophenone for intracellular studies to minimize steric bulk and UV irradiation time (reducing cell death during live-cell labeling).
 - Use Alkyne handles on the probe (and Azide on the tag) rather than vice-versa, as Alkynes are generally more metabolically stable and less reactive toward cellular thiols than Azides.

References

- Photoaffinity Labeling in Activity-Based Protein Profiling. Topics in Current Chemistry. [[Link](#)]
- Evaluation of fully-functionalized diazirine tags for chemical proteomic applications. Chemical Science. [[Link](#)]
- Recent advances in activity-based probes (ABPs) and affinity-based probes (AfBPs) for profiling of enzymes. Chemical Science. [[Link](#)][3][12]
- Targeting the Reactive Proteome: Recent Advances in Activity-Based Protein Profiling. Molecules. [[Link](#)]
- Protocol for clickable photoaffinity labeling and quantitative chemical proteomics. STAR Protocols. [[Link](#)]

Need Custom Synthesis?

BenchChem offers custom synthesis for rare earth carbides and specific isotopic labeling.

Email: info@benchchem.com or [Request Quote Online](#).

Sources

- [1. Fluorous Photoaffinity Labeling to Probe Protein-Small Molecule Interactions | Springer Nature Experiments \[experiments.springernature.com\]](#)

- [2. mdpi.com \[mdpi.com\]](#)
- [3. Recent advances in activity-based probes \(ABPs\) and affinity-based probes \(AfBPs\) for profiling of enzymes - PMC \[pmc.ncbi.nlm.nih.gov\]](#)
- [4. Chemical proteomics for a comprehensive understanding of functional activity and the interactome - Chemical Society Reviews \(RSC Publishing\) DOI:10.1039/D5CS00381D \[pubs.rsc.org\]](#)
- [5. researchgate.net \[researchgate.net\]](#)
- [6. Recent Advances in Target Characterization and Identification by Photoaffinity Probes - PMC \[pmc.ncbi.nlm.nih.gov\]](#)
- [7. pdf.benchchem.com \[pdf.benchchem.com\]](#)
- [8. benchchem.com \[benchchem.com\]](#)
- [9. Activity-based protein profiling: A graphical review - PMC \[pmc.ncbi.nlm.nih.gov\]](#)
- [10. pdfs.semanticscholar.org \[pdfs.semanticscholar.org\]](#)
- [11. biorxiv.org \[biorxiv.org\]](#)
- [12. researchgate.net \[researchgate.net\]](#)
- To cite this document: BenchChem. [Comparative Guide: Bifunctional Probes for Chemical Proteomics]. BenchChem, [2026]. [Online PDF]. Available at: [\[https://www.benchchem.com/product/b6271206/docs#comparative-guide-bifunctional-probes-for-chemical-proteomics\]](https://www.benchchem.com/product/b6271206/docs#comparative-guide-bifunctional-probes-for-chemical-proteomics)

Disclaimer & Data Validity:

The information provided in this document is for Research Use Only (RUO) and is strictly not intended for diagnostic or therapeutic procedures. While BenchChem strives to provide accurate protocols, we make no warranties, express or implied, regarding the fitness of this product for every specific experimental setup.

Technical Support: The protocols provided are for reference purposes. Unsure if this reagent suits your experiment?

Need Industrial/Bulk Grade? [Request Custom Synthesis Quote](#)

BenchChem

Our mission is to be the trusted global source of essential and advanced chemicals, empowering scientists and researchers to drive progress in science and industry.

Contact

Address: 3281 E Guasti Rd

Ontario, CA 91761, United States

Phone: (601) 213-4426

Email: info@benchchem.com

[Contact our Ph.D. Support Team for a compatibility check](#)